

# Simple Home Repair

*by Judy Ostrow*



A member of Penguin Group (USA) Inc.



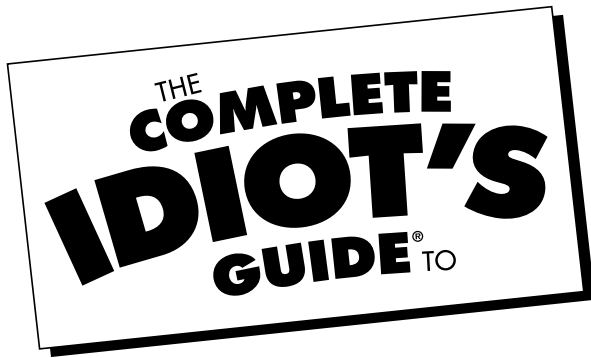

# Simple Home Repair

*by Judy Ostrow*



A member of Penguin Group (USA) Inc.

*This book is dedicated with love to Sam, Adam, and Rachel, my biggest cheerleaders.*

## **ALPHA BOOKS**

Published by the Penguin Group

Penguin Group (USA) Inc., 375 Hudson Street, New York, New York 10014, USA

Penguin Group (Canada), 90 Eglinton Avenue East, Suite 700, Toronto, Ontario M4P 2Y3, Canada (a division of Pearson Penguin Canada Inc.)

Penguin Books Ltd., 80 Strand, London WC2R 0RL, England

Penguin Ireland, 25 St. Stephen's Green, Dublin 2, Ireland (a division of Penguin Books Ltd.)

Penguin Group (Australia), 250 Camberwell Road, Camberwell, Victoria 3124, Australia (a division of Pearson Australia Group Pty. Ltd.)

Penguin Books India Pvt. Ltd., 11 Community Centre, Panchsheel Park, New Delhi—110 017, India

Penguin Group (NZ), 67 Apollo Drive, Rosedale, North Shore, Auckland 1311, New Zealand (a division of Pearson New Zealand Ltd.)

Penguin Books (South Africa) (Pty.) Ltd., 24 Sturdee Avenue, Rosebank, Johannesburg 2196, South Africa

Penguin Books Ltd., Registered Offices: 80 Strand, London WC2R 0RL, England

## **Copyright © 2007 by Judy Ostrow**

## **All illustrations copyright © 2007 by Karen Burgess**

All rights reserved. No part of this book shall be reproduced, stored in a retrieval system, or transmitted by any means, electronic, mechanical, photocopying, recording, or otherwise, without written permission from the publisher. No patent liability is assumed with respect to the use of the information contained herein. Although every precaution has been taken in the preparation of this book, the publisher and author assume no responsibility for errors or omissions. Neither is any liability assumed for damages resulting from the use of information contained herein. For information, address Alpha Books, 800 East 96th Street, Indianapolis, IN 46240.

THE COMPLETE IDIOT'S GUIDE TO and Design are registered trademarks of Penguin Group (USA) Inc.

ISBN: 1-101-03585-4

Library of Congress Catalog Card Number: 2007924618

Interpretation of the printing code: The rightmost number of the first series of numbers is the year of the book's printing; the rightmost number of the second series of numbers is the number of the book's printing. For example, a printing code of 07-1 shows that the first printing occurred in 2007.

Note: This publication contains the opinions and ideas of its author. It is intended to provide helpful and informative material on the subject matter covered. It is sold with the understanding that the author and publisher are not engaged in rendering professional services in the book. If the reader requires personal assistance or advice, a competent professional should be consulted.

The author and publisher specifically disclaim any responsibility for any liability, loss, or risk, personal or otherwise, which is incurred as a consequence, directly or indirectly, of the use and application of any of the contents of this book.

**Publisher:** *Marie Butler-Knight*

**Editorial Director/Acquiring Editor:** *Mike Sanders*

**Managing Editor:** *Billy Fields*

**Development Editor:** *Lynn Northrup*

**Senior Production Editor:** *Janette Lynn*

**Copy Editor:** *Ross Patty*

**Illustrator:** *Karen Burgess*

**Cartoonist:** *Richard King*

**Book Designer:** *Trina Wurst*

**Indexer:** *Brad Herriman*

**Layout:** *Chad Dressler*

**Proofreader:** *Aaron Black,*

*John Etchison, Mary Hunt*

# Contents at a Glance

<b>Part I:</b>	<b>Getting to Know Your House</b>	<b>1</b>
1	Your Personal Tool Kit <i>What equipment is essential for home repair? Tools can be categorized by the functions they perform; here's an illustrated and organized list you can use.</i>	3
2	Your Most Important Tool: The Safety Drill <i>Here's the gear and the rules you need to stay safe when you work on your house. Learn which jobs require professional help.</i>	21
3	Your Supply Closet <i>Gather an inventory of materials for home repair, including first-aid supplies for your house and leftovers from home projects that you won't want to throw away.</i>	31
4	A Map of Your World <i>Find the systems that power your home. Learn to operate their controls, and know what to do in case of an emergency.</i>	41
<b>Part 2:</b>	<b>Skin Deep: Repairing Surfaces and Openings</b>	<b>53</b>
5	Walls: From Trash Talk to Smooth Talk <i>Here is advice and detailed repair instructions for all types of surface materials, including drywall, plaster, tile, and wallpaper.</i>	55
6	Floors and Ceilings: Beneath Your Feet and (Not Really) Over Your Head <i>Repair blemishes to your hardwood floors, learn how to repair a resilient floor, and clean up carpet stains.</i>	77
7	Stairs: A Few Steps to a Happy Landing <i>Silence squeaks and tighten treads. Make sure that rails and balusters are solid. Keep children and elders safe around stairways.</i>	103
8	Getting Clear About Windows <i>How to deal with windows that get stuck or rattle. Avoid pane pain: learn to replace broken glass and worn screens.</i>	113

9	Doors: An Open-and-Shut Case	133
	<i>Understand the parts of a door and how to keep them working together so they don't stick—or stay open when you want them closed.</i>	
<b>Part 3:</b>	<b>The Circulatory System: Plumbing and Fixtures</b>	<b>151</b>
10	Solving Pipe Problems	153
	<i>Thaw pipes that have frozen and get tips for preventing future freeze-ups. Protect outside faucets from winter's chill, clear clogs from the sink, and rescue valuables that go down the drain.</i>	
11	Controlling the Flow: Faucets, Sprays, and Showerheads	167
	<i>Check out the four main faucet types and how to repair them. Clean a spitting faucet or a showerhead with a flawed flow. Figure out how to make a sink stopper pop after it's flopped.</i>	
12	Tub and Toilet Techniques	183
	<i>Spot-repair a tub surface and prevent leaks around the tub. Clear and prevent a clogged tub drain. Understand how your toilet works and diagnose various problems.</i>	
<b>Part 4:</b>	<b>Mission Control: Wiring, Appliances, Heating, and Cooling</b>	<b>197</b>
13	In the Loop: Understanding Your Wiring	199
	<i>Understand your home's electrical system and how to control its circuits. Map your own system, and make simple diagnoses, repairs, and replacements.</i>	
14	Smooth Transitions: Cleaning and Replacing Filters and Hoses	213
	<i>Change and replace the filters and hoses associated with washers, dryers, air conditioners, furnaces, and stovetops.</i>	
15	Appliance Repairs	223
	<i>Find an appliance model number and use manuals and help lines to troubleshoot appliance problems. Learn some easy repair techniques for common appliance ailments.</i>	
16	Heating and Cooling	235
	<i>Understand the basics about your equipment and how to recognize problems. Extend your water heater's life expectancy by learning to drain it and replace a crucial part.</i>	

<b>Part 5:</b>	<b>Preventive Maintenance: Safety and Upkeep</b>	<b>251</b>
17	Safety Must-Haves <i>Get the facts about installing and using smoke detectors, carbon monoxide detectors, and fire extinguishers. Develop a family emergency escape plan.</i>	253
18	Preventing Repairs: Inside Maintenance <i>Inspect your home twice yearly for small defects before they become big problems. Find out what tools you need and what to look for. Prevent pest problems.</i>	263
19	Preventing Repairs: Outside Maintenance <i>Give your home's exterior a closer look. Fix the landscape and drainage system so that your home's big enemies—water and weather—can't get started on a destructive path.</i>	273
 <b>Appendixes</b>		
A	Glossary	283
B	Online Resources	287
C	Home Inspection Checklists	293
	Index	305





# Contents

<b>Part I: Getting to Know Your House</b>	<b>1</b>
<b>1 Your Personal Tool Kit</b>	<b>3</b>
Quality Counts .....	4
Measure Up: Rule(r)s of the Road.....	4
Make Your Mark.....	6
The Cutting Edge: Sharp Helpers .....	7
Putting It Together: Tools for Fastening and Joining .....	9
<i>Basic Tools</i> .....	10
<i>Specialized Tools</i> .....	11
Demolition Derby: Tools That Take Things Apart.....	12
The One Tool You Can't Live Without.....	14
<i>Power</i> .....	15
<i>Speed</i> .....	15
<i>Keyless Chuck</i> .....	16
<i>Screwdriving</i> .....	16
<i>Helpful Bits About Drilling</i> .....	16
Put It There! Applying the Right Stuff.....	17
Hold It! Transporting Your Tools.....	17
I Can See Clearly Now .....	19
Your Work Space.....	19
<b>2 Your Most Important Tool: The Safety Drill</b>	<b>21</b>
Good Safety Habits .....	22
Safety Gear: The Basics .....	23
The Job Site.....	25
The Ups and Downs of Ladder Safety.....	26
<i>Choosing a Ladder</i> .....	26
<i>Using a Ladder</i> .....	27
Knowing Your Limits: When to Call a Pro .....	29
<b>3 Your Supply Closet</b>	<b>31</b>
DIY Depot: Storing Your Repair Stuff.....	32
The Supply Side .....	32
<i>Keep It Moving: Lubricants</i> .....	32
<i>Keep It Together: Adhesives</i> .....	33
<i>Fill the Gap</i> .....	34

<i>Cover It Up</i> .....	34
<i>Rub It Off: Abrasives</i> .....	34
<i>More Togetherness: A Quick Guide to Fasteners</i> .....	35
<i>Hold It: Containers</i> .....	37
In Case of Small Water Emergencies.....	37
Storing Those Leftovers!.....	39

**4 A Map of Your World 41**

The Main Thing: Your Home's Power Centers .....	42
Finding the Flow: Your Water Supply.....	42
<i>Oh, Well</i> .....	44
<i>Where the Well Water Goes</i> .....	44
Your Gas System (Outside the House).....	45
<i>If You Smell Gas</i> .....	45
<i>Other Gas Controls</i> .....	45
Your Electric Service .....	47
A Workbook for Your Home .....	49
<i>Appliance and Fixture Use and Care Manuals</i> .....	50
<i>Receipts and Manufacturer's/Dealer's Warranties</i> .....	51
<i>Equipment Manuals or Schematics</i> .....	51
<i>A Circuit Map of Your Home</i> .....	51
<i>Service Records</i> .....	52
<i>Other Workbook Items</i> .....	52

**Part 2: Skin Deep: Repairing Surfaces and Openings 53**

**5 Walls: From Trash Talk to Smooth Talk 55**

Minor Drywall Repairs .....	56
<i>Repairing Dings and Dents</i> .....	56
<i>Popped Nails</i> .....	58
<i>Patching Holes</i> .....	60
<i>Loose Drywall Tape</i> .....	62
Repairing Cracks in Plaster.....	62
Grout and Tile Crackups.....	64
<i>Replacing Grout</i> .....	65
<i>Replacing a Ceramic Tile</i> .....	67
Minor Wallpaper Repairs.....	70
<i>Bursting Those Bubbles</i> .....	71
<i>Flattening Flappy Seams</i> .....	72
<i>Patching a Torn Section of Wallpaper</i> .....	73

<b>6 Floors and Ceilings: Beneath Your Feet and (Not Really) Over Your Head</b>	<b>77</b>
Wood Floors: Skin Repair.....	78
<i>Water Marks</i> .....	78
<i>Burn Marks</i> .....	79
<i>Scratches and Gouges</i> .....	80
<i>Preventing Blemishes</i> .....	80
Floorboard Fixes.....	80
<i>Drilling Pilot Holes</i> .....	81
<i>Split or Cracked Boards</i> .....	81
<i>More Bit Bits</i> .....	83
<i>Warped Boards</i> .....	84
<i>Loose Boards</i> .....	85
<i>Stopping Squeaks</i> .....	87
<i>Getting at Squeaks from Down Under</i> .....	88
Resilient Floor Fixes.....	89
<i>Replacing a Vinyl Tile</i> .....	90
<i>Patching Sheet Flooring</i> .....	92
Ceramic Tile Floor Repairs.....	93
Carpet Capers.....	93
<i>Taking Up a Wall-to-Wall Carpet</i> .....	93
<i>Dealing with Spots and Spills</i> .....	94
<i>When Spot Makes a Spot</i> .....	96
<i>Replacing a Stained or Damaged Section of Carpet</i> .....	97
First Aid for Floating Laminate Floors.....	99
Ceiling Repairs.....	100
<b>7 Stairs: A Few Steps to a Happy Landing</b>	<b>103</b>
Parts of a Staircase.....	104
Silencing Squeaks.....	104
<i>A Lube Job</i> .....	104
<i>Repairing Squeaks from Below the Stairs</i> .....	105
<i>Fixing the Squeak or Loose Tread from Above</i> .....	106
<i>Getting a Grip on Handrails</i> .....	108
<i>Off-Base Balusters</i> .....	109
Safe Stairs.....	110
<i>Elder Safety</i> .....	110
<i>Kidproofing the Stairs</i> .....	111

<b>8</b>	<b>Getting Clear About Windows</b>	<b>113</b>
	What a Pane! Parts of a Window .....	114
	How Double-Hung Windows Work.....	115
	Stubborn Stuck Sash .....	116
	<i>Wait and See</i> .....	116
	<i>Gentle Tap, Tap, Tapping</i> .....	116
	<i>Don't Want to Pry, But</i> ... ..	117
	Windows That Won't Stay Open.....	119
	When Windows Break .....	121
	Screen Test.....	124
	Screen Repairs .....	125
	<i>Small Holes</i> .....	125
	<i>Replacing Screens</i> .....	126
	<i>Installing Security Pins in Windows</i> .....	129
<b>9</b>	<b>Doors: An Open-and-Shut Case</b>	<b>133</b>
	Anatomy of a Door.....	134
	Silencing the Talking Door.....	135
	Tightening Loose Hinges .....	136
	<i>Fix #1: Gum Up the Holes</i> .....	137
	<i>Fix #2: Longer Screws</i> .....	137
	Sticking Doors.....	138
	Doors That Won't Stay Closed .....	138
	Getting a Grip on Doorknobs .....	140
	<i>Tighten a Loose Knob</i> .....	141
	<i>Replacing a Passage, Privacy, or Keyed Entry Lockset</i> .....	143
	Screen and Storm Doors.....	143
	<i>Adjusting the Door Closer</i> .....	144
	<i>If You Need a New Closer</i> .....	145
	Lock and Key Dilemmas.....	145
	<i>Key Sticks in the Lock</i> .....	145
	<i>Key Breaks Off in the Lock</i> .....	145
	<i>Lock Is Frozen</i> .....	146
	<i>Locked in (Privacy Lock)</i> .....	146
	Installing a Peephole .....	146
	Sliding Door Fixes.....	148
	<i>Wobbly Tracks</i> .....	148
	<i>Dirty Tracks</i> .....	148
	<i>Bent Track</i> .....	149
	<i>Securing a Sliding Door</i> .....	149

<b>Part 3: The Circulatory System: Plumbing and Fixtures</b>	<b>151</b>
<b>10 Solving Pipe Problems</b>	<b>153</b>
Small Leaks: Emergency Fix.....	154
Thawing Frozen Pipes .....	156
<i>Hot Water Thaw</i> .....	157
<i>Applied Heat Thaw: Beware!</i> .....	157
<i>Preventing Frozen Pipes</i> .....	157
Another Cold Subject: Winterizing an Outside Faucet.....	158
Pipe Down! Quieting Noisy Pipes .....	159
Preventing Drainage Disasters .....	160
Unclogging a Sink.....	161
<i>Chemical Reactions</i> .....	161
<i>Taking the Plunge</i> .....	161
Meet the Sink Trap .....	162
<i>Clearing the Trap</i> .....	163
<i>When Valuables Go Down the Drain</i> .....	165
<b>11 Controlling the Flow: Faucets, Sprays, and Showerheads</b>	<b>167</b>
Faucet Facts .....	168
<i>Faucet Fix Prep List</i> .....	168
<i>Fixing a Leaky Compression Faucet</i> .....	169
<i>Still Dripping?</i> .....	172
<i>Fixing a Leaky Rotary Ball Faucet</i> .....	172
<i>Repairing a Cartridge Faucet</i> .....	174
<i>Ceramic Disk Faucet Fix</i> .....	175
Cleaning a Clogged Aerator .....	177
Brushing Up on Showerheads .....	178
<i>Cleaning Showerhead Outlet Holes</i> .....	179
<i>Removing/Replacing a Showerhead</i> .....	179
When the Pop-Up Stopper Flops .....	180
<b>12 Tub and Toilet Techniques</b>	<b>183</b>
Bathtubs: The Surface Story.....	184
<i>Concealing Surface Flaws in Porcelain-Enameled Cast Iron</i> .....	184
<i>Renewing a Scratched Acrylic Tub</i> .....	185
Waterproofing Around the Bathtub .....	185
Clearing a Tub Clog.....	187
<i>Pop-Up Stopper</i> .....	187
<i>Strainer</i> .....	187

<i>Take the Plunge</i> .....	188
The Worst Case: Toilet Clogs.....	188
<i>Low-Tech De-Clogging</i> .....	188
<i>The Toilet Plunge</i> .....	189
Other Toilet Trouble.....	190
<i>Inside the Tank: A Toilet's Vital Organs</i> .....	191
Stopping a Running Toilet.....	192
<i>Worn-Out Float Ball</i> .....	192
<i>Float Ball Won't Rise</i> .....	193
<i>Tank Stopper Won't Close</i> .....	193
The Flush Is Weak.....	194
Leak or Sweat?.....	194
When the Toilet Rocks.....	195

**Part 4: Mission Control: Wiring, Appliances, Heating, and Cooling    197**

**13 In the Loop: Understanding Your Wiring    199**

Time to Call a Pro?.....	200
Your Electricity Dictionary.....	200
Mapping Your Electrical System.....	201
Calculating the Load on Your System.....	204
Receptacle ID.....	205
But Is It Grounded?.....	207
GFCI: Initials You Need to Know.....	208
Shattered! Replacing a Bulb That Breaks in Its Fixture.....	209

**14 Smooth Transitions: Cleaning and Replacing Filters and Hoses    213**

De-Linting the Clothes Dryer.....	214
Clothes Washer Hoses and Filters.....	215
<i>Replacing Washing Machine Supply Hoses</i> .....	215
<i>About Metal Mesh Household Hoses</i> .....	217
<i>Cleaning and Replacing Washing Machine Water Inlet Filters</i> ... 218	
Cleaning the Room Air Conditioner Filter.....	219
Cleaning or Replacing a Forced-Air Furnace Filter.....	220
Cleaning a Range Hood Filter.....	220

**15 Appliance Repairs    223**

Ailing Appliances: Diagnosis.....	224
<i>What's Your Model?</i> .....	224
<i>Troubleshooting</i> .....	225

<i>Manufacturer Help</i> .....	225
Refrigerator Repairs.....	226
<i>Keeping Your Cool</i> .....	226
<i>Poor Door Seal</i> .....	226
<i>Cleaning Condenser Coils</i> .....	227
<i>Water in the Cabinet</i> .....	228
<i>Closing the Open Door</i> .....	229
Water Underneath the Refrigerator.....	230
<i>Leaky Drip Pan</i> .....	230
<i>Leaky Icemaker Supply Line</i> .....	230
Dishwasher Dilemmas.....	230
<i>Leaky Drain Connection</i> .....	231
<i>Dirty Dishes</i> .....	231
Washing Machines: On the Move?.....	231
Jammin' with Your Garbage Disposal.....	232
Service Calls and Replacement.....	234

**16 Heating and Cooling 235**

Maintenance of Heating/Cooling Equipment.....	236
Gas Heat.....	236
Oil Heat.....	237
Electric Heat.....	239
Troubleshooting Your Heating System.....	239
<i>Gas Furnace</i> .....	240
<i>Lighting the Pilot—or Not?</i> .....	240
<i>Electric Heat</i> .....	241
<i>Oil Furnace/Boiler</i> .....	241
DIY Heating System Maintenance.....	242
<i>Filtering Forced Air Systems</i> .....	242
<i>Ducts, Vents, and Registers</i> .....	242
<i>Cleaning Radiators</i> .....	243
<i>Bleeding Radiators</i> .....	243
<i>Steam Heat</i> .....	244
Water Heaters.....	245
<i>Basic Water Heater Anatomy</i> .....	245
<i>Testing the Pressure Relief Valve</i> .....	246
<i>Replacing the Pressure Relief Valve</i> .....	247
<i>Draining the Water Heater</i> .....	248
Central Air.....	248

<b>Part 5: Preventive Maintenance: Safety and Upkeep</b>	<b>251</b>
<b>17 Safety Must-Haves</b>	<b>253</b>
Your #1 Safety Device: Smoke Detectors.....	254
<i>Chirpy Smoke Detector</i> .....	254
<i>Testing the Smoke Detector Alarm</i> .....	255
<i>Replacing the Batteries</i> .....	255
<i>Smoke Detector Placement</i> .....	256
Carbon Monoxide Detector.....	256
<i>Installing the CO Detector</i> .....	257
<i>Replacing the CO Detector Battery</i> .....	257
<i>If the CO Alarm Goes Off</i> .....	257
Fire Extinguisher Facts .....	258
<i>Using the Extinguisher</i> .....	259
<i>Storing the Extinguisher</i> .....	259
<i>Maintaining the Extinguisher</i> .....	259
Emergency Exit: Your Family Plan .....	260
Your Little Red Book .....	261
<b>18 Preventing Repairs: Inside Maintenance</b>	<b>263</b>
Your House Detective Tool Kit .....	264
<i>Tools</i> .....	264
<i>The Lists</i> .....	264
Inspection Checklists: How to Use Them .....	265
<i>Basement/Utility/Laundry Room</i> .....	265
<i>Bathrooms</i> .....	266
<i>Kitchen</i> .....	267
<i>Attic/Under Roof Crawl Space</i> .....	268
<i>General Inspection</i> .....	268
Keeping Out Water and Critters.....	269
<i>Screening Attic Vents</i> .....	269
<i>Rodent-Proofing Gaps</i> .....	270
Planning Ahead for Maintenance .....	271
<b>19 Preventing Repairs: Outside Maintenance</b>	<b>273</b>
Outside Inspection .....	274
<i>Foundation</i> .....	274
<i>Walls, Windows, and Doors</i> .....	275
<i>Roof</i> .....	276
<i>Landscape</i> .....	276



Maintaining Your Home's Exterior .....	277
Gutters and Drainage.....	277
<i>How Gutters Work</i> .....	277
<i>Cleaning Gutters and Downspouts</i> .....	278
<i>Directing Water Flow: Extenders and Splash Blocks</i> .....	279
<i>Small Gutter Repairs</i> .....	280
Driveway Repair .....	280
Finding and Using a Pro.....	281

**Appendixes**

<b>A Glossary</b>	<b>283</b>
<b>B Online Resources</b>	<b>287</b>
<b>C Home Inspection Checklists</b>	<b>293</b>
<b>Index</b>	<b>305</b>



# Introduction

There's a truism about houses: sooner or later, whatever can go wrong, will go wrong. Most people recognize this phrase as Murphy's Law, but after twenty-five years of fixing things, I know that it's also the First Law of Homeownership.

Because stuff goes bad—often in a hurry, usually when you least expect it, and most likely when there's a tiny balance in your checking account—being able to diagnose a small problem before it's a big one, and even fix it yourself, is a very nice aptitude to develop.

That's what got me excited about writing *The Complete Idiot's Guide to Simple Home Repair*.

After about a year in our first house, we had a new baby and lots of bills, and the First Law of Homeownership kicked in. Pipes froze, the pump died, and the gutters started leaking. I noticed that moss was growing on the garage roof! My husband traveled all the time, and so the ball was in my court. I had to fix some of this stuff myself, or we'd go bust paying repair people.

So I took the next step: I started learning about my house's structure, systems, and appliances, and started down the DIY highway.

I was a bit tentative at first, but the simple repairs I completed successfully encouraged me to try others. When I did call repairmen, I asked them to explain what they were doing, and why. I picked their brains about the finer points of my house's plumbing, wiring, heating, and appliances. Pretty soon, my friends were calling *me* to walk them through the fixes for their own appliance breakdowns and plumbing disasters.

In this book, I pass along what I've learned, along with lots of good advice from fellow DIY-ers and seasoned pros. I hope you find that acquiring these skills is fun and empowering. And I hope that the knowledge will save you money; it's saved me and my family plenty!

Taking care of a home is quite a bit like taking care of ourselves; keeping it in shape requires maintenance and, when needed, tweaks and touch-ups to keep it looking and functioning at its best. Like our own bodies, a home has lots of parts and systems that need care and attention. We can do a good portion of the work ourselves. And when things happen that are beyond our scope and ability, we call in an expert.

This book will acquaint you with many modest efforts you can make yourself to keep a house in shape. It's designed as a sensible, starter volume for someone who's never worked on a house before but wants to learn. It tells you what tools you need, and how to work safely. There are no big, complicated repairs here—no major surgery. But you'll find lots of step-by-step instructions, many illustrated, to help you become well acquainted with your house and take a role in its well-being.

### How to Use This Book

*The Complete Idiot's Guide to Simple Home Repair* contains 19 chapters and 3 helpful appendixes. Here's how it's structured:

**Part 1, "Getting to Know Your House,"** is a beginner's guide to equip and prepare yourself for doing home repairs effectively and safely. It tells you everything you need to know about the tools, supplies, and safety equipment that anyone interested in DIY repairs should have. It also provides you with an orientation about your home's systems, and how you can control them.

**Part 2, "Skin Deep: Repairing Surfaces and Openings,"** teaches you some basic repair techniques you'll use for your home's most visible parts. You'll find out how to make dinged and dented walls and ceilings look new, and remove some of the squeaks and bounces in floors and stairs. This section will also help you get your home's simplest moving parts—the windows and doors—moving smoothly.

**Part 3, "The Circulatory System: Plumbing and Fixtures,"** deals with all the places where water runs through your home: kitchens, baths, and the supply lines that deliver this most necessary element to the fixtures you use every day. Tackle emergency repairs and learn the techniques to address minor problems with plumbing fixtures and fittings.

**Part 4, "Mission Control: Wiring, Appliances, Heating, and Cooling,"** covers the systems and conveniences that make your home run like it's the twenty-first century. While your wiring, many appliances, and the heating system in your home may be complex and major repair beyond your beginner's scope and talents, you can learn some simple fixes and do some needed maintenance on your own.

**Part 5, "Preventive Maintenance: Safety and Upkeep,"** teaches you about installing, maintaining, and using the necessary equipment for home safety. It also provides you with a routine to keep up with the maintenance of your house, inside and out, to prevent small problems from becoming larger ones.

To round out your beginner skills, you'll find a Glossary of the specialized vocabulary for house parts, systems, and repair techniques you should know; a chapter-by-chapter list of Online Resources for additional information about specific repairs, tools, materials, and training; and helpful Home Inspection Checklists that you can photocopy and use to keep track of your home's condition—both inside and out—on a regular basis.

## Extras

For every repair in the book that requires tools and materials, you'll find a helpful checklist to gather what you need. And in every chapter are little helpful nuggets to further expand your knowledge without flipping back and forth in the book. Watch for them:

### def•i•ni•tion

The boxes quickly clarify words and phrases related to house parts and home repair that you may not have encountered before.



### Ounce of Prevention

These little "red flags" let you know when you must be extra careful, or when you can take some action to save time or money.



### What Pros Know

Experienced DIY-ers and repair people who fix houses for a living know a lot of facts and shortcuts. Get their tips here!

## Acknowledgments

For as long as I've been learning about home repair, I've had patient, willing teachers to guide me in learning the empowering secrets of getting hands-on with a house. And I am so appreciative that because of them, I've developed some mechanical know-how that I would otherwise have never possessed.

First there was my dad, who engaged me with the sweet smells of the lumber yard, deep bins of nails, screws, nuts, and bolts, the mysteries of his big metal tool box, and all those gadgets in the basement. He could fix anything; I am still in awe.

I bow to my first carpentry teachers, Patti Garbeck and Lizabeth Moniz, who helped me get past the noise and speed of power tools and tame, if not defeat, the fear factor. They'll both tell you that respect for your tools and what they can do is a good thing.

For learning about my own houses I owe a lot of helpful and talkative (once I got them started) contractors: Steve Sfera, Richard Gates, Bob Warner, Todd Lawson, Curt Haskell, and many others who've let me look over their shoulders.

A great hardware guy or woman is invaluable when you're looking for just the right tool, material, or part for a job. Thanks to Joe di Pietro, Jr., at Chubby's Hardware in Pound Ridge, New York. Whenever I was stumped, he could point the way. I hope everyone who reads this book can find a hardware salesperson as helpful.

On safety issues, thanks to Lorraine Carli, a spokesperson at the National Fire Protection Association, for her help with a most important subject.

For the ways of old doors and doorknobs, I thank Mike at Old House Parts, in Kennebunk, Maine.

For her pictures that saved me thousands of words, I am deeply grateful to my illustrator, Karen Burgess, whose clean and beautiful drawings will surely help any beginning repair person. And to her model, Lisa McCarthy, thanks for demonstrating some intricate repair moves that made the illustrations just right.

I deeply appreciate the editorial assistance that made the book's concept a reality. Mike Sanders at Alpha Books set everything in motion. Warmest thanks are also due to Lynn Northrup, Jan Lynn, and Ross Patty, whose thoughtful suggestions and unflagging attention made the journey through their word processors feel like a spa makeover. I am also grateful for the encouragement of my agent, Bob Diforio, without whom this wonderful project would not have come my way.

## **Trademarks**

All terms mentioned in this book that are known to be or are suspected of being trademarks or service marks have been appropriately capitalized. Alpha Books and Penguin Group (USA) Inc. cannot attest to the accuracy of this information. Use of a term in this book should not be regarded as affecting the validity of any trademark or service mark.

# Part 1

## Getting to Know Your House

Of course, your house is more than the sum of its many parts: it's your *home*. But even before you start the little jobs that will make it look better or run more smoothly, you need to know some basic information.

First of all, the right tool makes common repairs easier and quicker, and you should acquire a basic assortment. Also, if you're going to do repairs yourself, you need to do them safely. There are a few important rules for keeping you, your family, and your home safe when doing repairs, and they're simple to learn. Next, you need a few basic supplies that you can use for a variety of repairs, as well as a couple of things that will serve you well in small emergencies. And finally, if your house has electric power, a gas supply, and running water, you need to know where the main controls for each system are located, and how to start and stop them.

Even if you were never a Scout as a kid, the organization's motto is a good one: "Be prepared." By the time you finish Part 1, you'll be equipped and ready for lots of the little glitches and mishaps that homeownership is sure to send your way.



*"Do we have some kind of water shut-off thingy?"*

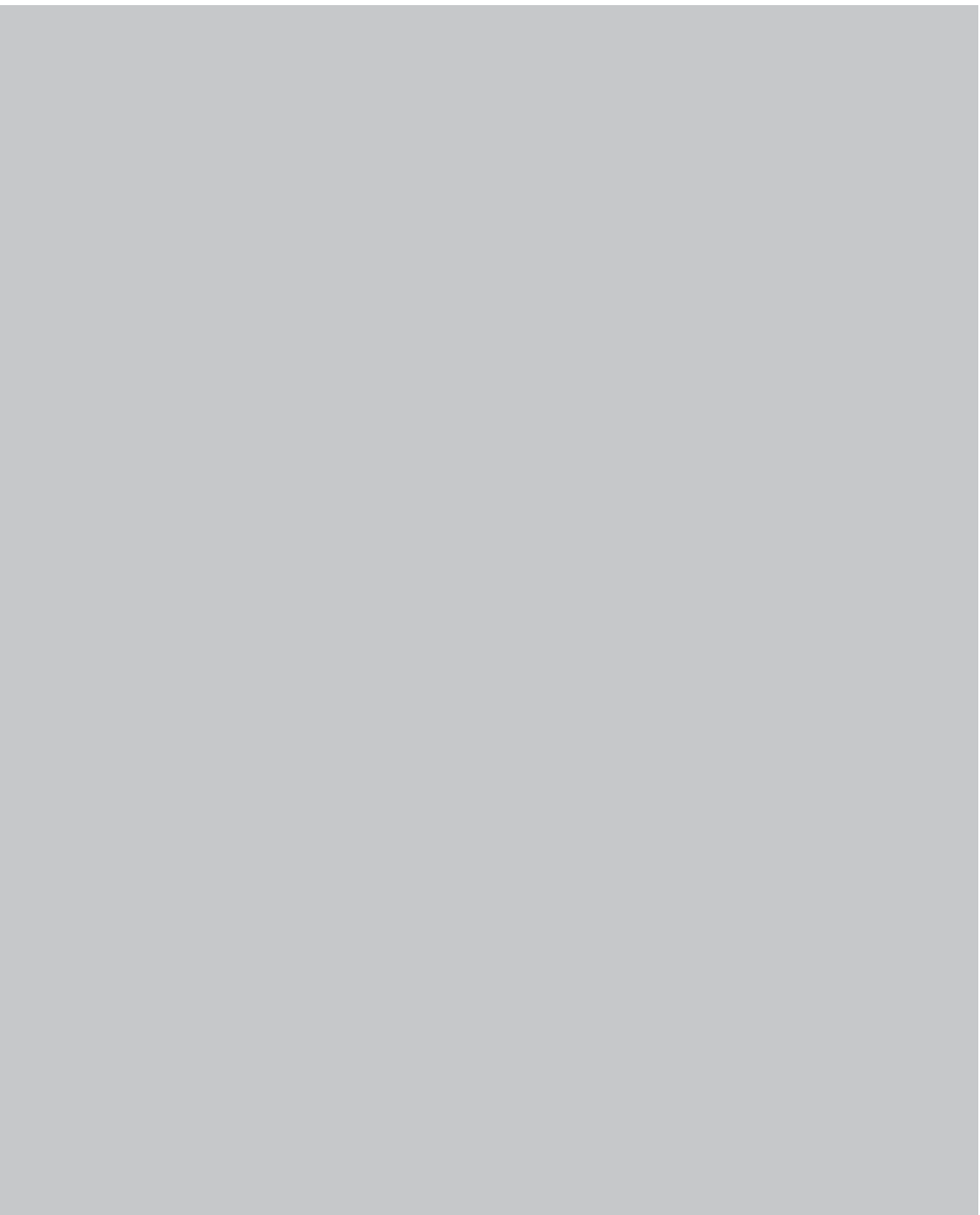



# Chapter

# 1

## Your Personal Tool Kit

### In This Chapter

- ◆ When it comes to tools, quality counts
- ◆ The basic categories of tools
- ◆ Must-have tools in your starter set
- ◆ The one power tool you'll need for repairs
- ◆ How to choose the right tools for you

I've never tried it, but I could probably knit a sweater using two pencils, and coax a nail out of the wall with the tip of a metal ruler. But pencils weren't designed for knitting, and the ruler isn't really a nail-pulling tool. Having the right equipment for a task usually makes the work easier, quicker, and safer.

Home repair and improvement can be broken down into a handful of actions: measuring and marking, cutting, fastening and joining, taking apart (also known as demolition), and applying. A few tools can do more than one thing, but this way of sorting them will help you remember what their primary use is.

If you can, hold a new tool in your hand before you buy it; it should be a comfortable fit, like a good pair of shoes!

## Quality Counts

You can buy a cheap set of tools, and they'll probably work fine, at least for a while. Expect to replace the bargains after a couple of years. Often made of lesser-grade metals and plastic, the tips, teeth, and edges of inexpensive tools will show wear sooner, rather than later. When it comes to tools, quality counts ... and costs. Most of the well-known brand name manufacturers produce tools at differing quality levels, with professional grade being the best and most expensive of the lot. Good tools will probably last a lifetime, and you can leave best-quality equipment to your grandchildren!

Sets of multiple sizes of screwdrivers, wrenches, and the like will be cheaper than buying each item singly. However, unless you're planning to repair your whole house yourself, unassisted by friends or hired hands who have their own tools, don't go overboard. Buy the best equipment you can afford and, except for the most basic tools, buy them as you need them.

If cash is tight, and you're *really* good about returning things you borrow, neighbors and friends might loan you their equipment. Take good care of borrowed tools, and return them *promptly*. Most folks I know are very possessive of their toolbox, and want things returned in the same condition as when they were loaned. If your borrowing etiquette is poor, most lenders won't give you a second chance!

## Measure Up: Rule(r)s of the Road

A sturdy 20- or 25-foot retractable *measuring tape* is indispensable for all kinds of jobs around the house. Some people opt for the lighter-weight, 12-foot model, but eventually realize that the longer one is more versatile.

These come in plastic or metal cases, and the best have a stop lever so that you can extend and hold the tape in its extended position, without holding on to the case. This is a particularly good feature when you're marking the distance of long runs around a room.

About those little tick marks along the tape: carpenters can tell at a glance whether a mark indicates  $7\frac{3}{8}$  inches or  $7\frac{5}{8}$ . If you're not so good at fractions, get a tape with a fractional read. This measure has the intervals—eighths, quarters, and halves of inches—marked clearly with the appropriate fraction, so you don't need to guess.

Better-quality tapes also have a clasp that makes it easy to attach the case to your belt while working, so you don't have to constantly hunt for it.

A metal ruler—also known as a *straightedge*—is another handy device for measuring. It serves as a ruler and as a rigid guide for a utility knife or glass cutter when you want to score a surface. An 18" straightedge is a good size for lots of jobs. Straightedges are also available in plastic; metal is slightly more expensive but much more durable.

A *speed square* has a lot of uses in carpentry, allowing you to mark angles, then draw guidelines. One of the straight sides of this triangular device has a lip, which can fit along the edge of a piece of material (a 2x4 piece of framing lumber, for example) letting its other straight side serve as a guide for marking/cutting a piece of wood or other material at a perfectly perpendicular angle (90 degrees). Speed squares are made in metal and plastic; I like the heft and feel of the metal variety.

Unless you're planning to do lots of carpentry, you don't need a big, fancy, and expensive carpenter's level. Instead, opt for a small *torpedo level*, so called because of its shape, to check whether shelves, rods, curtain poles, doors, and other household objects are hanging straight horizontally (level) or vertically (plumb). The torpedo level is one type of spirit level, so called because the measuring device employs a vial filled with liquid, usually ethanol—the "spirit"—containing an air bubble that falls between guidelines when the instrument rests plumb or level.

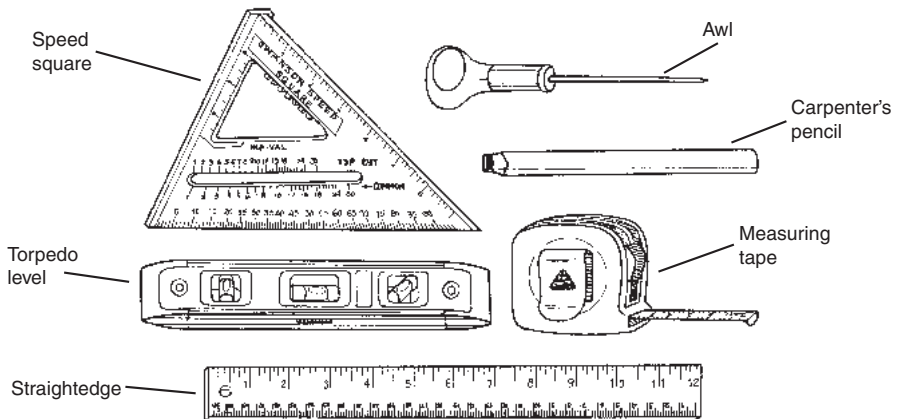

Measuring and marking tools.



**Ounce of Prevention**

Though its name sounds like a guided weapon, a torpedo level is easily damaged. If you drop it, it may no longer read true. So handle it with care!

## Make Your Mark

An *awl* is a tool with a handle attached to a slim metal shaft with a pointed tip; it looks like a miniature ice pick. It can punch a hole in a piece of leather or a strip of wood, but for our purposes, it's a great way to scratch-mark the location for a new screw or nail on a wall or other surface.

An awl is one of those tools you can pick up for a quarter at a tag sale. Some older models have nice wooden handles. Just make sure that the shaft is firmly attached to the handle, or the tool is useless.

If you like to stash your pencil behind your ear, any sharpened #2 pencil is a good marker for your measurements and guidelines. A lot of pros think the garden-variety yellow pencil is just fine, too, but some like the *carpenter's pencil*, which can be sharpened with a utility knife and won't roll away. It looks like a regular pencil flattened by a steamroller! One disadvantage is that the carpenter model does not have an eraser attached; carpenters may not need erasers when they make marks, but sometimes newbie DIY-ers (do-it-yourselfers) do!

Sometimes using a pencil line as the guide for installing a fastener or making a cut leaves a mark that's wiggly, and leaves you scratching your head about the right location. Or, you used a dull pencil and the line is too thick to be precise. Instead, mark the right spot with a V. Put the point of the V at the spot you measured (see next figure). Then your nail or cut will be true to your intentions.

There's an old saying—a carpenter's old saw, to be precise—that goes, “Measure twice, cut once.” This alludes to the importance of making good measurements, then checking them before you pick up your other tools.

When I first learned to use a circular saw, I measured twice, then turned on this most awe-inspiring power tool and made my cut. The cut was perfect, but my measurement was not; my piece was off by a quarter inch! I had to put my beautiful 2×4 in the “use later” pile for another part of the cabin I was working on.

Scrap you don't use becomes expensive trash. Until I mastered measuring, I always measured *three times*, or until I got the same measurement twice in a row. DIY 101-ers, take heed!

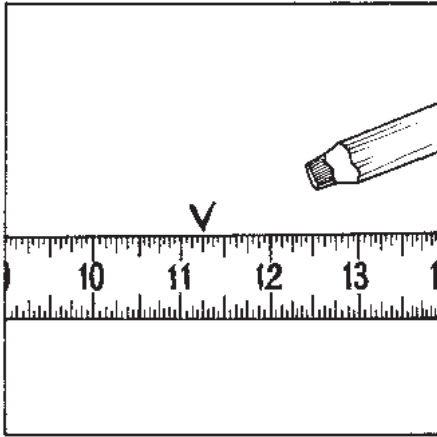

*V-mark measurement.*

## The Cutting Edge: Sharp Helpers

You need just a few sharp tools for most of the cutting you'll do for basic improvements and repairs.

I don't know about your house, but in mine, *scissors* tend to migrate, like all those socks that disappear in the dryer, never to be seen again. To remind yourself to return them to your toolbox when you've "borrowed" them for another purpose, take a piece of masking tape and label your toolbox scissors ("Mom's toolbox," or "Dad's toolbox," or "My toolbox") so they aren't MIA when you need them. Sturdy scissors with 5" blades should handle most cutting tasks nicely.

There are so many uses for a *utility knife* around the house that a list of them could practically fill this book. Although you can pick up a plastic, pencil-sized, 99-cent model at most hardware checkout counters, invest in the standard, palm-filling metal model. It fits comfortably in your hand, and you can adjust and retract the blade with a simple lever. Plus, it uses disposable blades that can be stored inside the handle. It costs a couple of bucks and will last a lifetime.



### Ounce of Prevention

The blade of a utility knife is very sharp. Always keep the business end retracted when you're not using the knife.

*Wire cutters* do what they say. In a pinch, you can repeatedly twist a wire until it breaks from all the abuse, but a wire cutter does the job in a single snip!

When you're learning repair and DIY skills, the most versatile hand saw for cutting wood is called, simply, a *toolbox saw*; it has a fairly short blade (about 15 inches or so), and is easy to use. Look for a model that can be re-sharpened, as all saws will lose their edge over time. The toolbox saw is good for making short cuts; remember only to apply pressure on your downstroke (push).

Although it may look scary, it works great. I'd never seen a *Japanese pull saw* before I took a course in carpentry for women a few years ago. The one pictured is a double-edged saw; one side has coarse rip teeth for cutting wood with the grain, and the other side has more closely spaced cross-cut teeth, for (did you guess?) cutting across the grain. It looks like a most imposing spatula, and unlike the American toolbox saw, it cuts on the pull stroke—a much easier and more elegant way to saw, to my way of thinking. And when the saw gets dull, you can buy a replacement blade.

*Cutting tools.*

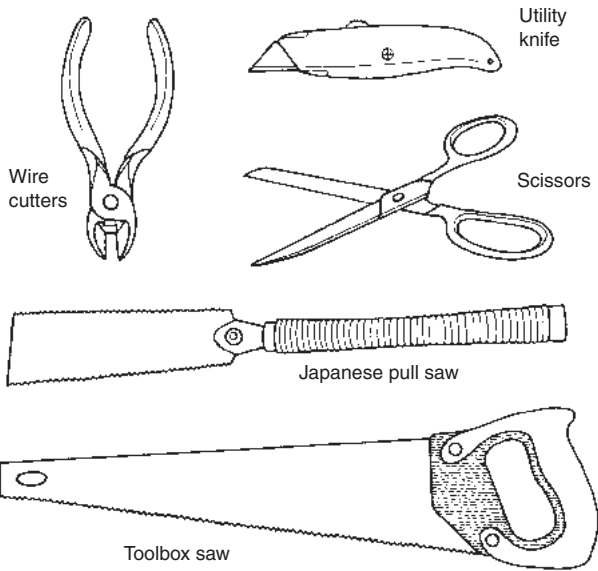



### What Pros Know

The first time I used a toolbox saw, I started hacking away, using pressure while I pushed down and pressure when I pulled back. Being a more sensitive creature than you'd think, the saw bucked and whined, and later, my husband accused me of dulling the blade. He was right! Saws cut one way; most American saws will cut on the push—the downstroke; Japanese saws will cut on the pull movement. I never noticed this little wrinkle when I was growing up, watching my Dad do stuff around the house. But now I know. If you get a chance to try before you buy, you can decide which type of saw you prefer.

## Putting It Together: Tools for Fastening and Joining

Nail meets wall, screw meets joist. Putting things together is a major part of home repair and improvement. Having a good selection of tools to make this togetherness happen is an important facet of homeownership. Because, as you will discover, things meant to be together will sometimes fall apart!

*Fastening/joining tools.*

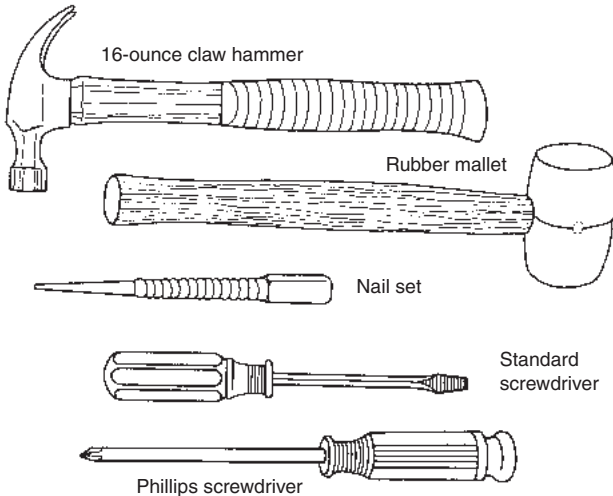

## Basic Tools

A hammer is such a basic piece of equipment that it should be anyone's going-away present when leaving the comfort of Mom and Dad's house, where things so magically stayed together. A *16-ounce claw hammer*, with a curved claw for pulling out nailing mistakes, is a good basic size and style. You can tell the difference between this one and the larger framing hammer (for putting up walls and other work requiring nailing above one's head, or at funny angles), because the framing hammer has a longer handle.

There is usually such an array of hammers at the home center or hardware store that you may have trouble choosing. Pick what feels good in your hand. Don't choke up on the hammer handle, but use the handle as an extension of your arm. If the 16-ounce model feels too heavy, drop down to a 12-ounce. But don't go for a cheap, wimpy, 7-ounce hammer (these are sometimes part of an equally cheap set of fastening/joining tools). This mini is good for tacks but not much else.

Sometimes you need to drive in a nail but don't want to damage the surrounding area, so the metal head of your claw hammer won't do. An inexpensive *rubber mallet* gets the job done.

Another tool that lets you drive a nail below a surface (called countersinking) while leaving the surrounding area undisturbed is a *nail set*. Often sold in sets of three or more standard sizes to match different nail heads, you can position the nail set over the nail head to drive your nail smoothly "underground."

A good selection of screwdrivers belongs in every tool kit. Composed of a shank with a flat tip that looks like a minus sign (-), called a *standard* screwdriver, or a tip that looks like a plus sign (+) called a *Phillips* screwdriver, with a handle of wood, metal, or some type of hardened plastic, screwdrivers are available in a number of point sizes. Shanks also come in a number of different lengths: long shanks let you reach into tight spaces; short, stubby shanks give you more turning power.



### What Pros Know

Always use the right size driver for the fastener you are driving. Use the Phillips screwdriver for Phillips head screws (more prevalent than single-slot screws today). Use the standard driver for slotted screws. Too-big or too-small driver points can damage or deform the fastener. And don't forget this helpful saying: "Righty, tighty; lefty, loosey." Translation: tighten by turning to the right (clockwise); loosen by turning to the left (counterclockwise). It works for screws, nuts, light bulbs. Any threaded object turns on the same principle.



## Specialized Tools

A good hammer and half a dozen screwdrivers will suffice for probably 75 percent of the joining and fastening tasks in your home. But other fastening tools, for grasping and turning specialized fasteners, and holding the work while you do the job, are great to have on hand.

Allen wrench set

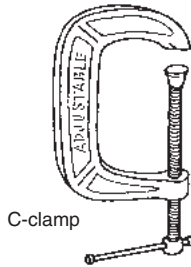
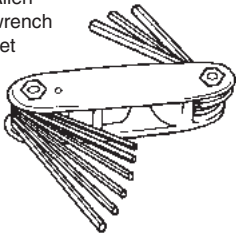

C-clamp

Needlenose pliers

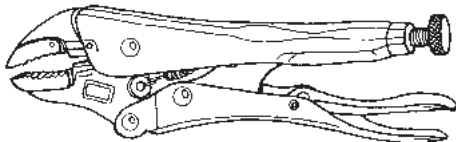
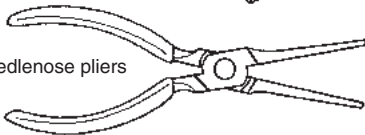

Locking pliers

*Wrenches, pliers, and clamps.*

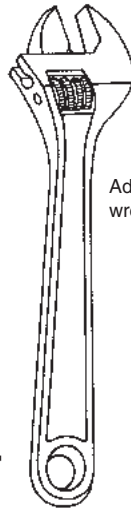

Adjustable wrench

Nuts, big bolts, pipes, hard-to-reach wires—sooner or later, you'll have a job that requires more specialized gear to help you grab hold of an irregularly sized piece of something, keep it steady, turn it, move it, or attach it to something else.

Sometimes, door latches, light fixtures, or other house hardware is joined with fasteners that require a hexagonal tool, called an *Allen (or hex) wrench* to attach or detach a part. Allen wrenches are sold in sets, sometimes conveniently encased in a penknife-like sheath. This is a good way to buy them, since the wrenches are comparatively small and easy to lose. Simply extend the right size wrench, leaving the others tucked away in the sheath.

An *adjustable wrench* is a great way to get hold of a nut so that you can loosen and remove it from its bolt. The jaws of the wrench hold tight to the nut with a few turns of the little adjusting gear. While you can buy a set of wrenches that fit perfectly around each size nut, often the size you need will be missing from the set. (This has happened to me more than once at crucial moments such as—gulp!—Christmas Eve, with something complicated that needs assembly.) An adjustable model is inexpensive and versatile.

If you're all thumbs, *needlenose pliers* are perfect for “grab and twist” workouts with wires of all types—phone, electrical, audio. They look just like their name sounds. If you're working with electric wires, choose a model with insulated handles, one of the many safeguards against shocks you'll learn about as you read this book.

*Locking pliers* are another handy tool; the most famous variety is the Vise-Grip brand, invented by a smart Danish-American from Nebraska named William Peterson. He wanted a tool that worked like pliers and could grip metal parts in his blacksmith shop “like a vise.” They still do, and several manufacturers have variations on this tool, which has a lever that locks the jaws of the pliers in place. They work like a third hand for many jobs.



#### **Ounce of Prevention**

If you want to protect the surfaces you're clamping together, insert little pieces of wood or cardboard, also known as shims, between the clamp jaws and the work piece, so the clamps don't leave a mark.

When you have to glue things together and hold them tightly in place until the adhesive dries, *C-clamps* will do the job. There are a variety of other, more expensive clamping devices, and you can explore the shelves of the hardware or woodworking shop when the time comes to expand your collection.

## **Demolition Derby: Tools That Take Things Apart**

The pros call it “demo,” and they usually enjoy this part of home improvement: you see the results of your work nearly instantly. Some of you may think this sounds like your kind of fun. But before you start tearing up that 70s shag carpet in the den, remember that you'll have to figure out what to do with what lies beneath the fuzzy, matted mess. And it might not be pretty. So before you tear anything apart, think: can I live with the result for a while?

Sometimes you get lucky. In one room of our family's Maine house, armed with utility knives and small pry bars to remove the furring strips, my niece and I tore out an old, worn red carpet that was driving me crazy. It was a messy job, but we found a wax-and-buff-ready maple floor beneath.

We were not so lucky in the kitchen. Beneath the multicolor indoor/outdoor carpet was a glued-down layer of carpet padding. Beneath that was a layer of brown linoleum with yellow, red, and green spots. And beneath that was a layer of fifty-year-old goeey black adhesive. Having made this discovery in an inconspicuous corner of the kitchen, I knew my limits, and called in the pros. But it was several months before they could schedule the work and reveal the golden planks of the original maple floor.

So be careful about using your demolition tools!

*Pry bars* come in many different sizes; keep one that's about 8"–10" long in your tool kit. It can neatly squeeze under old tile, flooring, or carpet furring strips, and its lever action plus your muscles make quick work of many demo jobs. (One company even calls its model the "Wonder Bar," a great name for this handy tool.)

I've always been a cat person, but never heard of the handy *cat's paw* until I went to carpentry class. Like its larger cousin the crowbar, this sturdy tool is a fairly heavy (for its size) round or hexagonal bar of steel. It curves at one end to form a cup-shaped tip with a V-slot that can grip around a nail head. Hammer just above the back of the V-slotted tip, working the slot around the nail head. When the nail head is seated in the slot, rock back the cat's paw and the nail glides out (finish it off with your hammer claw). It's a beautiful piece of equipment for removing nails when you don't care how the surrounding wood looks afterwards (you can lessen the damage by sliding a shim under the "heel" of the V-slotted paw as you work out the nail). You may not need this tool right away, but when you get to taking out old work with lots of nails, this will come in handy.

A *cold chisel* is another one of those old tools that show up at tag sales on the cheap. It gets its name from the fact that this tempered steel cutter is used for cutting "cold" metals, and not used in conjunction with heat, as in torches or forges. Paired with a hammer to drive its point, it's a good tool for removing cemented tile. Just remember that when you're cutting into hard materials, these can chip and fly. Always wear safety goggles and other protective gear; see Chapter 2 for the particulars.

*Demolition tools.*

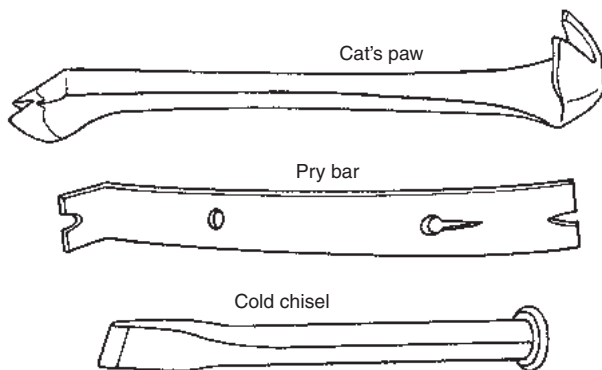

## The One Tool You Can't Live Without

For the repairs in this book, you'll need just one basic power tool: an *electric drill*.

Corded models have been around for years, but battery-powered drills are so improved that they are worth more than a second look. You won't have to plug into a socket with the cordless variety, so it's much more versatile. For optimum use time, buy one with a charger and two batteries (one to use, one spare to keep charged when you're doing a lot of drilling and don't want to lose power at a crucial moment).



### What Pros Know

Don't forget the feel-good factor! Get a drill with the features you want, but also make sure it feels comfortable in your hands and doesn't weigh you down. If it doesn't feel right, you've wasted your good money.

A visit to the power tool department of your hardware or home center can be a heady experience: so many drills, lots of different prices. When considering which to buy, think about what you need.

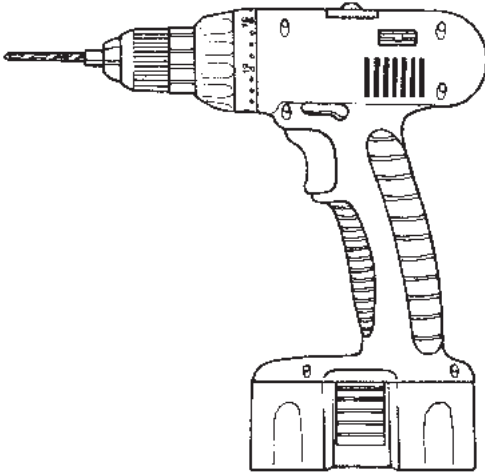
*Cordless electric drill.*

## **Power**

Most DIY (not pro-grade) corded models quote power in the range of 500 to 1,000 watts. The higher-wattage models will have sturdier parts and be able to take more abuse.

Same with cordless; 9.6-volt batteries don't pack the power of a 12V- or 18V-powered cordless drill. If you are going to use the drill a lot, or want it to last, opt for the most power you can handle (the higher voltage battery packs and sturdier parts increase the weight of the tool).

There are different types of batteries for cordless drills; the most common are Nickel Metal Hydride (Ni-Mh) and Nickel Cadmium (Ni-Cd, or "ni-cad").

## **Speed**

Single-speed drills lack versatility. If you're using large bits for big holes, the bit needs to turn more slowly or you'll wear out the bit quickly. A step-up option is a drill with two fixed speeds—there's usually a manual switch that makes this adjustment.

A variable speed control offers an infinite number of speeds up to an indicated (read the package) limit. You control the speed by a trigger, and some drills have adjustable trigger stops so you don't accidentally put the tool in overdrive when high speed is not needed.

## Keyless Chuck

In the old days, bits were inserted into the business end of the drill by opening and closing the *chuck* (which holds the shaft of the bit) with a key. After a bunch of years, manufacturers realized that people always lost the key, so drills with a keyless chuck are pretty standard these days. Lots of pros love them; my dad had one, but I haven't seen a keyed chuck drill in years!  $\frac{3}{8}$ " is the most common chuck size, and right for the work in this book.

## Screwdriving

For your drill to work like a screwdriver, it needs three attributes: variable speed, a reverse drive, and a torque control that shuts off the drill when a certain turning force is reached. You know the drill has this last feature if there's a numbered dial (up to 16 positions). Torque control prevents you from driving the screw too deeply or too tightly.

## Helpful Bits About Drilling

If you've never used an electric drill before, know that it's destined to make many home repairs simpler than you can imagine. Here are a few tips for using it safely and well:



### What Pros Know

If you're driving a bunch of screws, find the right turning force for the job by testing your setting and screw on a scrap piece (wood or drywall). Oh, and one more thing: to use the drill like a screwdriver you'll need screwdriver bits!

- ◆ Always wear safety goggles when you drill. That stuff you're drilling has to go somewhere, and you don't want that somewhere to be your eyes.
- ◆ Use the highest speeds for jobs that use the small bits, and slower speeds for big bits.
- ◆ Indent your drill-in point with a nail or the tip of a nail or screw. This will prevent the drill from sliding off the mark.
- ◆ Leave the motor running when you're removing the bit from your work. If the drill ever gets stuck in the work, turn off the drill and then restart it in reverse.

## Put It There! Applying the Right Stuff

Lots of repairs use patching compounds, adhesives, and other stuff best applied (or smoothed) with a tool. These are almost self-explanatory:

- ◆ *Putty knives* come in a variety of widths; they're great for applying all kinds of goop for various repair chores. They're also quite useful for scraping, lifting, and prying in certain circumstances. A narrow one (2") and a broader one (4–6") are a good basic pair to own. Better models have metal ends on the handles that will take the force of a hammer (when you're trying to open a stuck window, for example) without breaking the handle.
- ◆ A 2" nylon-bristle *paintbrush* and a clean *old toothbrush* can be used to brush away dust or other particles, and also to apply various liquids.
- ◆ A household *sponge* is good for cleanups, but it's also good as an applicator for certain liquids. Keep a clean one handy.

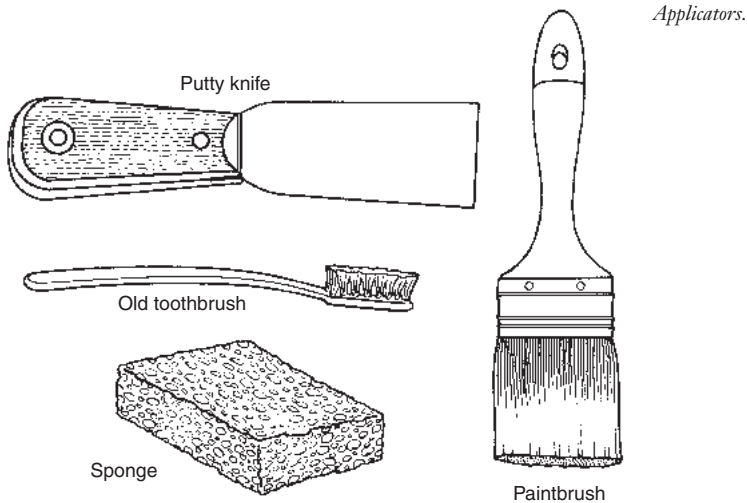

## Hold It! Transporting Your Tools

Box, bag, or bucket? When you're assembling tools to do a repair job, it's good to have a container that holds everything you need. I like my canvas rigger's bag. It holds a ton of tools, was inexpensive, and is incredibly sturdy. However, you can get a tool

bucket, which is an ordinary bucket equipped with a canvas tool holder that makes an incredibly roomy tool caddy. Or opt for a conventional toolbox. Go for sturdy, go for capacity, and choose a container that has enough slots for those tools you want to keep handy, or those you want to protect from other tools banging against them.

*Tool bag.*

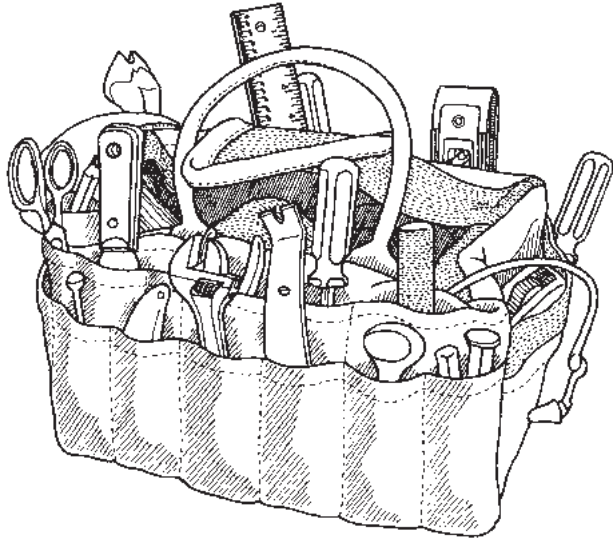

Tool belts are another personal choice. I like the simple canvas apron that costs a couple of dollars. It has a few sturdy pockets to hold the fasteners I'm using and a small tool or two. I use the tool bag to carry the rest of the stuff. Too many tools around my waist weigh me down.

Some people opt for the heavy belt with leather or canvas pockets and a nice loop in which to slide the handle of your hammer. My husband bought me one of these when I went off to carpentry class. I use it sometimes, but the hammer kept hitting me in the thigh and gave me a bruise after a week of building. I did notice, however, that my carpentry teacher had a solution for this: she maneuvered the belt so the hammer hung over her backside, and whenever she needed it, she'd just reach back and pull it out. What's that old saying? Each to his/her own!



## I Can See Clearly Now

No set of tools is complete without a working flashlight. Because so much repair goes on in basements, attics, and other dimly-lit recesses of the house, buy one that fits in your tool bag, make sure it lights, and stick an extra set of batteries for it in the bag for good measure!

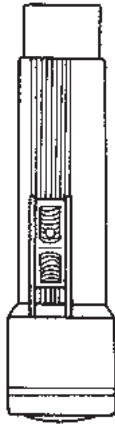

*Flashlight.*

## Your Work Space

Most of the repairs in this book are done on-site, where the damage has occurred. But once in a while you'll need to cut or saw something, and will need a flat, durable surface on which to place and maneuver your work.

If you're reading this book, you probably don't have a big, fancy workbench with a *vise* to hold things. The good news is: there are many fairly inexpensive substitutes for this handyman's standby.

If you're old enough to remember the film *The Graduate*, when actor Dustin Hoffman was a young man, there's a memorable scene when an old guy gives our hero a word to live by: *plastics*.

### def•i•ni•tion

A **vise** is a tool with two jaws, closed by a screw or a lever to hold objects immobile.

If you've got very little space to set up a workbench, a couple of companies now make very sturdy, hardened plastic, portable workbenches that fold into a couple of inches

of space in a small closet, and give you a place to set and clamp your work. This is a worthy investment.

And if you're a purist, a sheet of plywood clamped to a pair of sawhorses (you can buy a sturdy, folding, portable pair for less than forty bucks) will serve you well for most jobs, and also fits into a small space for storage.



**Ounce of Prevention**

Never work with a saw or other cutting device without clamping the work piece to the work surface. 'Nuf said.

The key here is sturdy, stable, and clamp-able. A work surface should support your work and keep it steady, and you should be able to hold your work piece in place with a clamp.

When you graduate from DIY 101, you can move on up to one of those big hardwood workbenches that sell for a couple of hundred bucks at specialty wood-working shops. But you won't need it right now.

**The Least You Need to Know**

- ◆ Cheap tools don't last long; get the basics, but get the best you can afford.
- ◆ Tools can be categorized by their functions: measuring and marking, cutting, fastening and joining, demolition, and application.
- ◆ An electric drill should be your first power tool; look for features you'll really use, and a model that feels good in your hands.
- ◆ You need a stable, sturdy surface for some DIY work where you can clamp a piece that needs cutting or sawing.
- ◆ There are portable options that are easy to store if your working space is limited.

# Your Most Important Tool: The Safety Drill

## In This Chapter

- ◆ Seven habits of intact DIY-ers
- ◆ What gear you'll need to stay safe when working on your house
- ◆ Ladder safety, top to bottom
- ◆ How to set your own limits, and hire a pro when you need one

Okay, so you just bought a house, and a slew of new tools, and you're ready to fix everything that seems to be ailing your new digs.

Not so fast. You've got one more little investment to make, and that's the insurance you provide for your own personal safety. I'm not talking about your homeowner's policy, but the commonsense rules you follow when you work on your house.

A few years ago, I wanted to expand my DIY know-how and signed up for a course in carpentry. I was eager to learn, and couldn't wait to get my hands on some of the terrific tools that make renovation and improvement easier to do myself. Before the course ever started, the school sent me a list of safety equipment to bring and use. And when my classmates and I arrived,

our teachers sat us down for a discussion of self-protection and good work habits. Their guidance was invaluable to my class, and to any beginner do-it-yourselfer who wants to stay safe.

I've used the equipment I brought, and the rules I learned, ever since. Except for a couple of minor scrapes and bruises, the knowledge has served me well. I'll share it here.

## Good Safety Habits

Basically, there are seven things to keep in mind when you work on your home. Think of them as the seven habits of intact DIY-ers:

1. **Choose the right wardrobe.** When you work with tools, don't wear anything that can get tangled up in your work. Leave off the bracelets, earrings, and anything that dangles. If you have long hair, tie it back or wear it up, or under a cap or bandanna.

Wear comfortable work clothes. If you are working with something dusty, or something that makes debris, cover up!

Sturdy shoes that cover your feet, with non-slip soles, will help prevent injury. Never wear sandals or flip-flops; they're an invitation to hazards like splinters and dropped tools—ow!



### Ounce of Prevention

Sturdy shoes are good, but steel- or titanium-toed work boots are better. Spring for a pair and you won't have to worry about broken toes. These industrial-strength boots are available in men's and women's sizes. My friend Siobhan, who installed all the siding on her 4,000-square-foot house, put pink shoe laces in her steel-toed footwear for a feminine touch! She keeps the ends of the laces tucked in to prevent tripping.

2. **Make sure your tools are clean and in good repair.** Inspect the cords of power tools and extension cords for signs of wear. Never work with damaged equipment.
3. **Wear your safety gear.** The goggles and earplugs will do nothing to protect your eyes and your hearing if you leave them in your bag. Carry and use your safety equipment, every time!
4. **Check your attitude.** Don't tackle a job if you're feeling tired, rushed, or upset. You're setting yourself up to lose focus, and that's when accidents happen.
5. **Take a break every couple of hours.** If you need a breather, hang out with your family, kids, or pets away from the worksite. Chit-chat can be distracting while you're working on something, so save the socializing for your timeout.

6. **Keep your worksite organized and clean.** Protect nonwork areas from debris with drop cloths and/or newspaper. Carefully follow the directions for any chemicals or compounds you are using; if they say “make sure the area is well-ventilated,” open the windows!
7. **When you need one, ask a friend to help.** If you’re working on a ladder that needs holding, or just need an extra pair of hands, make sure you’ve got the assistance you need.

Lastly, trust your gut! If a little voice inside your head says, “Maybe this job is just too much for me,” listen. Better to pay a pro than the bill from the E.R.

## Safety Gear: The Basics

Here’s a rhyming couplet to remember:

*Eyes, ears, nose,  
Fingers and toes!*

When you finish a repair job, you want to keep all those parts I’ve just mentioned!

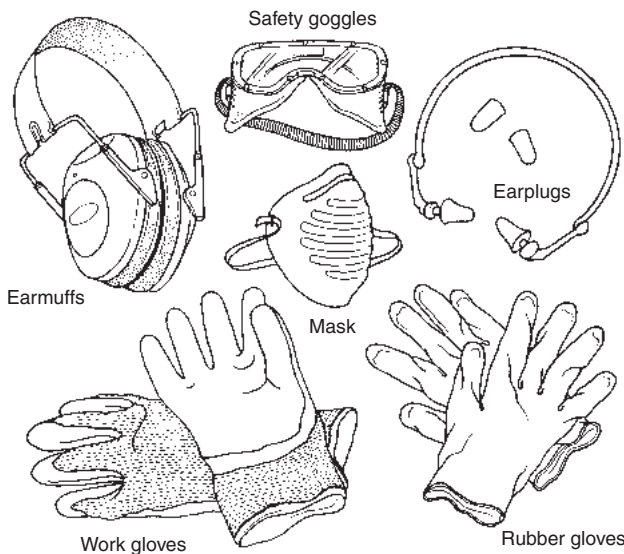

*Safety gear: don't start a job without it!*

Good *safety goggles* are not designed for high fashion, but to protect your eyes and their socket area from injury. They are usually made of high-quality plastic and won't shatter when hit; they'll also protect eyes from spilled or airborne liquids. Make sure the pair you use gives good coverage. Some styles use conventional earpieces, just like eyeglasses or sunglasses; others are secured by elastic. Just make sure the pair you select fits, and stays on when you're looking up, down, and side-to-side.



### What Pros Know

At a certain age, most people need glasses to magnify close work, such as reading fine print, attaching/detaching jewelry clasps, and discerning the details of a home repair. Instead of wearing your reading glasses under goggles, which can feel uncomfortable and appear awkward, look for a pair of safety goggles equipped with magnifying lenses; these make the goggles look like bifocals. These specialized glasses are made by at least one major manufacturer of work safety equipment, in varying strengths (1.5, 2.0, 2.5, and so forth). If you can't find them in your local hardware/home center, check Appendix B for a source.

Hearing loss is a progressive ailment; it results from long-term exposure to high levels of noise. Foam *earplugs* or safety  *earmuffs* should be used in noisy work environments—when power tools or other loud equipment is in use. It isn't necessary, but I also like to wear my safety earmuffs when I'm using any equipment that makes noise I don't like—the vacuum cleaner, for instance. Even though I haven't seen any evidence that proves vacuum noise can hurt your hearing long-term, it makes the experience more pleasant for me!

Wearing a *mask*, also called a respirator, to avoid inhaling dust or chemical-laden fumes is always a good idea. In order to get the right mask, you need to read the manufacturer's label. Depending on the products you are working with, you will need differing amounts of protection. Masks are labeled for the kinds of dust and fumes they filter.

There are several different types of disposable masks, which are the economical choice unless you are working repeatedly with materials that produce particles or fumes you don't want to breathe. If you're doing a lot of work that requires protecting your lungs, then it might be more budget-wise to buy a reusable respirator, which has replaceable filters, rather than a large quantity of disposable masks.

A pair of sturdy *work gloves* in a heavyweight fabric—canvas, leather, or one of the rugged new synthetic fabrics—will protect your hands when you’re carrying materials that could splinter or irritate your hands in some other way. Unless you lose them, a good pair can last a lifetime. *Rubber gloves* will protect your hands from prolonged exposure to liquid, and a tight-fitting pair of surgical-style latex gloves can protect your skin from irritants often found in certain paints, adhesives, and other repair compounds. (If you’re allergic to latex, use a different type of tight-fitting glove to protect your hands.)

As discussed in the previous section, wear appropriate, sturdy footwear to protect your toes!



### Ounce of Prevention

Not all safety masks are created equal. The National Institute for Occupational Safety and Health (NIOSH) sets standards for workplace safety equipment. When a product is labeled “NIOSH approved,” it means that the mask meets certain workplace standards for the process and/or material (painting, drywall, fiberglass) indicated.

## The Job Site

If you can set up, work, and finish your repair in a day, the seven habits of intact DIY-ers should be enough rules to keep you safe.

For projects of longer duration, remember the following:

- ◆ Train your kids, your pets, your elders—anyone who’s not working with you—to keep away from a work site unless they’re invited to observe. You can show them what you’re up to when you’re on a break.
- ◆ Repair materials and tools should be safely stored away whenever you finish for the day. If toxic materials like paint and solvents or power tools are being used, keep them out of reach of children or pets, even when you just step away for a couple of minutes.
- ◆ Drop cloths and spread-out newspaper can be slippery for other members of your household who are not dressed for the work; pick them up and sweep at the end of a repair session. Replace the protective coverings when you start the next day (or the next weekend).

This may seem logical to most readers, but sometimes an extra step for safety—securing tools and materials *just in case* a child or pet may get curious, or carefully

picking up *just in case* someone's not paying attention—seems like too much work to others. Making a mistake that someone you love might have to pay for is just too high a price.

Be safe, not sorry.

## The Ups and Downs of Ladder Safety

When you have jobs in tall places, a ladder is a terrific help. But be careful! According to the American Academy of Orthopedic Surgeons (AAOS), more than half a million people wind up in emergency rooms every year because of mishaps with ladders. Don't become another statistic. Follow these tips to stay safe.

### Choosing a Ladder

Safety begins when you choose your ladder. Most people start with a stepladder that's good for indoor jobs, and some outdoor work as well.

- ◆ **Materials:** Wood is traditional, but subject to rot and weathering. Aluminum is lightweight, but metal is not good for working around electricity. Fiberglass is the current preference of professionals; it is versatile, lightweight, and sturdy, but more expensive than either wood or aluminum.



#### Ounce of Prevention

When you buy a stepladder, there will usually be a sticker on the pail shelf that says "This is not a step," and one on the step below the top of the ladder that says "Do not stand above this step." Take these cautions seriously. If you need to climb higher, you'll need a taller ladder.

- ◆ **Height:** If you have standard, 8-foot ceilings, a 5-foot stepladder will probably be fine for any indoor task, and a lot of outdoor work, too. For stepladders, the ladder's height plus 4 feet equals the height limit you can achieve.
- ◆ **Strength:** Ladders have a duty rating—the amount of weight they can carry—established by the American National Safety Institute. Type 1A extra heavy duty carries up to 300 pounds; Type I heavy duty will carry 250 pounds; Type II medium duty 225 pounds; and Type III light duty 200 pounds. Err on the side of a heavier rated model when you're in doubt as to which model to choose.



## Using a Ladder

Safe ladder use means taking a few steps in the right direction:

- ◆ Don't wear leather soles; they're slippery. And tie your shoelaces securely. Likewise, don't wear baggy pants or loose clothing that could catch on the sides of a ladder or nearby obstructions.
- ◆ Inspect your ladder before you use it. Check it for any loose screws, hinges, or rungs. Clean off any dirt, grease, or dried spills. If the ladder has defects that can't be fixed, replace it.
- ◆ Place the ladder on a firm, level surface. Don't place a ladder on uneven ground, or prop up with bricks or other small items under the legs.
- ◆ Climb or descend with your hands on the side rails, not on the treads.
- ◆ Never position a ladder in front of a door that opens in the direction of the ladder unless the door is locked, blocked, or guarded on the other side. If you're working while other household members are moving around, put some tape and a sign across the door frame on the inside so they don't accidentally open it and topple you!
- ◆ Don't stretch—move the ladder instead. Reaching or leaning too far to either side of the ladder can make you lose your balance and fall. The AAOS has a good guideline: your bellybutton should not go beyond the sides of the ladder!
- ◆ Move things with caution; if you're cleaning out closet or garage shelves, always keep the load in your arm small enough that it doesn't throw you off balance. Push and pull things carefully.
- ◆ Get help if you need it. If you feel the least bit wobbly, have someone hold the ladder. And two people should never be *on* the ladder at the same time.

When you're outside, you may need to use an extension ladder if you have tall gutters or need to reach an outside light to replace it. Learn additional rules of using long ladders in Chapter 19.

*Keep your body centered on the ladder.*

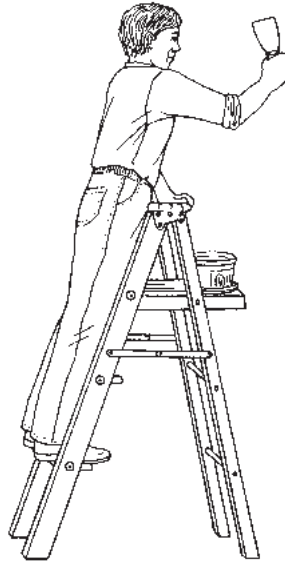

*Don't lean far outside the rails of the ladder. It's easy to lose your balance in this position.*

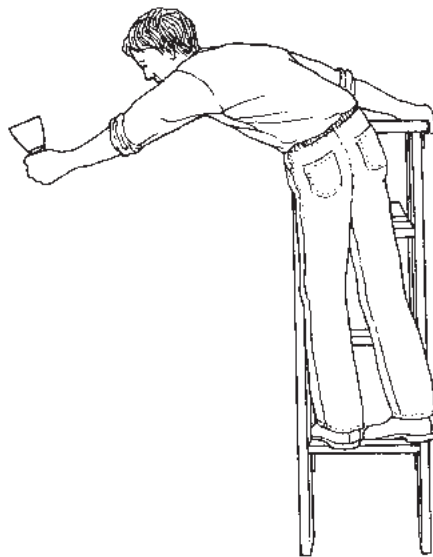

## Knowing Your Limits: When to Call a Pro

Some people like to try everything; others know what they're good at, and only occasionally stray into unfamiliar territory. Only you know your own degree of risk tolerance for DIY tasks. You may really like working on walls and floors—all those nice, solid things—but go queasy at the idea of clearing the gunk-clogged trap under the kitchen sink.

It's best to start your DIY career with those jobs that you feel comfortable and safe doing. As you build your confidence, you can tackle more things.

Here are three questions to ask yourself before you try doing a new kind of repair:

- ◆ Do I have the time?
- ◆ Do I have the tools—or can I get them easily?
- ◆ Do I have the skill?

The tasks in this book are not large ones; they require only small amounts of labor, tools, and know-how. This is, after all, a guide to *simple* home repairs. But if any jobs in this book make you hesitate for more than a few minutes after reading the instructions, or if you have to answer “no” to any of the three questions listed above, then you're probably right to call in the pro.

And should you call the handyman, the plumber, or the electrician, watch him or her do the job. You may learn something you'll be able to do yourself—next time.

## The Least You Need to Know

- ◆ Eyes, ears, nose, fingers, and toes all need protection when you work.
- ◆ Tackle repairs when you're rested and calm; working when you're tired or stressed invites accidents.
- ◆ When on a ladder, stay centered; when you need to lean out to reach what you're after, it's time to move the ladder.
- ◆ Know thyself! Make your first home repairs the ones you feel most comfortable with. Success begets confidence.



# Chapter 3

## Your Supply Closet

### In This Chapter

- ◆ Where to store your tools and supplies for home repairs
- ◆ Which supplies solve different repair dilemmas
- ◆ The subtle differences between fasteners
- ◆ The importance of leftovers (the home repair kind)

There are a couple of rules about household repair problems and the supplies that fix them:

1. Repair emergencies usually happen at night, or on weekends and holidays when it's hard to find someone to help you.
2. A few inexpensive supplies can save a lot of money and grief.

If you can impress upon yourself that bad stuff will happen to your house at the worst possible times, you will not be stuck, as I was, trying to stop a leaky pipe with my finger while being told by my plumber's answering service that he wouldn't be back for a week. I had an infant and a 3-year-old, and had to shut off the water to the whole house while the kids and I drove to the home center at 9 P.M. for emergency repair supplies. Of course, my husband was out of town!

## DIY Depot: Storing Your Repair Stuff

All the tools and materials in the world are worthless if you can't put your hands on the right item when you need it.

Lots of handy gentlemen and ladies dedicate a corner of their spotless garage to a workbench and storage area, but maybe you're not lucky enough to have such a clean corner, or even a garage.

A closet shelf, a cleared cabinet—any place you can get to easily, but also close off and make child- and pet-proof, if these wonderful creatures share your home with you, is fine for storage.



### Ounce of Prevention

You do not want your children playing with grown-up tools, tampering with sharp objects like nails and screws, or investigating the contents of bottles of adhesives or cans of lubricants. Whatever place you choose for your repair tools and supplies, make sure it's out of the reach of children and pets. If not, secure the door of your supply storage area with a keyed or combination lock.

## The Supply Side

As your home repair savvy grows, you'll be doing more jobs and adding to your supply cabinet. But for starters, here are some basic supplies to keep on hand.

### Keep It Moving: Lubricants

The places where parts come together often need a bit of help to move smoothly and quietly, or to get unstuck when they haven't been moved in a while.

A spray or liquid *lubricant* can help when you've got a noisy hinge, a draggy sliding door, or a nut that just won't turn when you're trying to loosen it. WD-40 is a popular brand of lubricant that comes in a can; it has a narrow straw that attaches to its sprayer so that you can direct a stream of lubricant to a precise location.

Lubricants are useful for hundreds of chores and repairs. Special lubricants that contain a high percentage of silicon are often helpful for moving parts made of wood, vinyl, or rubber. See Appendix B for more helpful information.

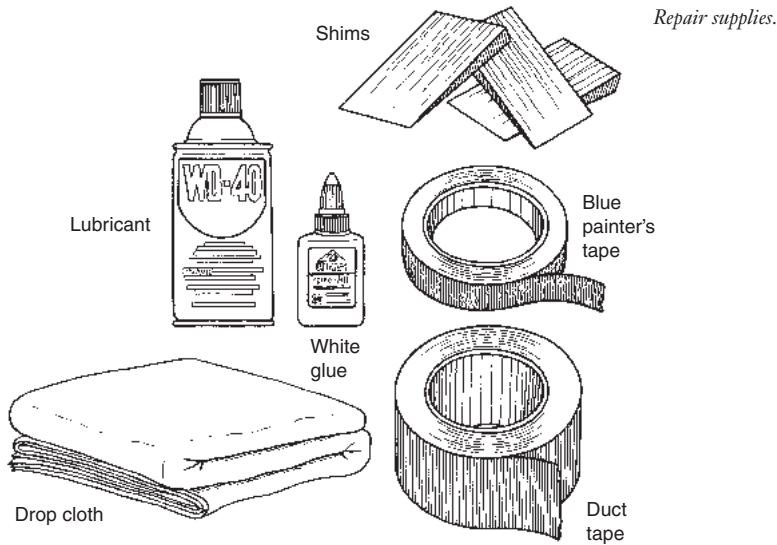

## Keep It Together: Adhesives

While there are many varieties of adhesive—for every kind of material that can break or fall apart—you can start with a single basic type. *White glue*, available in supermarkets, stationery stores—virtually everywhere—is good for sticking together paper, cardboard, wood, leather, cloth, and lots of other materials. Keep a container in your supply closet. Keep in mind, however, that it's not waterproof; you'll need a different adhesive when water resistance is required.

When you start working with wood, add a container of carpenter's (wood) glue, which is usually yellow and of the same consistency as white glue.

Specialized adhesives—instant glue or contact cement, for example—are powerful products that create an incredibly tough and virtually instantaneous bond. If you use them, follow directions carefully, and keep the appropriate solvent on hand in case you stick your fingers together!

*Blue painter's tape*, like the familiar off-white masking tape, is a light-duty adhesive tape that is easy to apply and remove. The blue variety is called painter's tape because its adhesive is formulated to lift off a surface without damaging a new coat of paint; regular masking tape can be difficult to remove because it makes a tighter bond, and will

often lift off the new paint, shred, or leave a residue if it's left on a surface too long. The blue stuff is good for holding many lightweight objects in place temporarily.

*Duct tape*—most people know the gray or silver-colored variety—has a strong adhesive backing because its original use was to seal gaps in lengths of flexible ductwork. (This is no longer an approved use in most building codes.) People have found thousands of uses for duct tape, and written books about it, but it's an emergency fix for a lot of breaks and tears in household objects: patching a small hole in window glass until you can replace the pane; holding two pieces of wood together while you screw or nail them. Having it in your supply closet will definitely prove handy at some point.

## **Fill the Gap**

Small *shims* are little wedges of soft wood, usually cedar, that look like miniature shingles. They're useful for closing gaps between stair treads and risers, for example—you'll see them used in some repairs in Chapter 7.

They're also good to level out a table, couch, or chairs when your floors are uneven—just slide a couple under the wobbly leg. While pieces of corrugated cardboard will work as shims in a pinch, a package of these little wooden helpers is cheap; if you've got an older home, I guarantee you'll find uses for them.

## **Cover It Up**

A *drop cloth* is essential for protecting the areas of your home where you're doing a repair. Many people use plastic drop cloths; they're cheap and disposable. But they're also slippery to walk on, and some are so thin that they tear with little provocation. Buy a 9'x12' canvas model and you can shake it out, fold it easily, even wash it when it gets too soiled.

## **Rub It Off: Abrasives**

Get at least one sanding block with a combination of surfaces—a medium-grade grit (80–100) side and a finer grit (120–150) is a nice toolbox standby. It's easier to handle than sheets of sandpaper. 220-grit sandpaper or blocks are good for fine surface work such as touch-ups to floors and furniture.



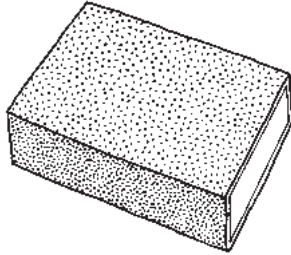

*Sanding block.*

Eventually, you may also want to get some files: a metal file and a wood rasp for quickly filing edges of these materials.

### More Togetherness: A Quick Guide to Fasteners

A variety of fasteners for joining house parts and hanging accessories is good to keep on hand. Invariably if you have a giant coffee can full of wood screws, what you'll need are a couple of brads. Fasteners are generally inexpensive bits of metal, so a good supply won't set you back more than a few dollars.

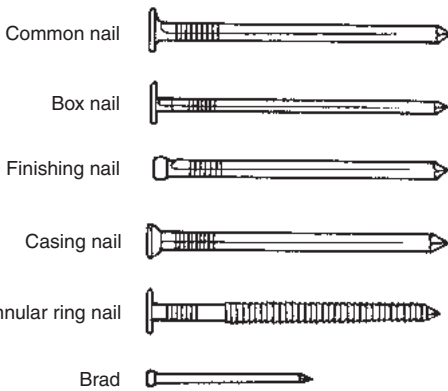

*An assortment of practical fasteners.*

Screws.

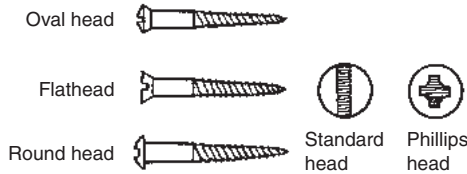

*Common nails* and their more slender brothers, *box nails*, are good for general use. They have fairly large heads and good holding power; coated varieties will grip even harder.

Nails used for outside work should be galvanized (zinc coated); in high-moisture areas—by the shore, for example—stainless-steel nails will hold up to the environment best.

Because their heads are relatively large, use common and box nails when surface appearance doesn't matter.

Small-headed nails—*casing* or *finishing nails*—are good for woodwork. Both can be countersunk with a nail set, and the hole filled with wood putty to leave a smooth surface for painting or finishing. Use the smaller *brad* for nailing very thin pieces of molding or paneling.



**What Pros Know**

In the United States, nails are sized in “pennies,” symbolized by the letter “d.” This sizing system is a traditional one, going back to England a few hundred years ago. A 2d, or two-penny nail, is 1 inch long; the longest nails, 60d, are 6 inches long. The rule of thumb is to use a nail that is 2½ to 3 times as long as the thickness of the piece being fastened.

For some of the repairs in this book, you'll use *annular ring nails*, which have a grooved shaft to “bite” into wood like a screw.

Screws have great holding power, and because they can be loosened or tightened, they can be removed without undue damage to the surrounding surface. Depending on what's being fastened, you can use *flathead* (flush to the surface), *round head* (sits atop the surface), or *oval head* (usually for decorative use) wood screws.

Wood screws are available with a *standard* (looks like a minus [-] sign) or *Phillips* (looks like a plus [+] sign) driver slot. Some professionals like to use screws with a square slot (called a Robertson), which requires a matching, square-headed driver.

If you like to cover your walls with art, you'll probably have use for an assortment of fasteners for hanging pictures and other decorations. Picture hooks that feature an

angled receptacle for driving in a small nail with ease—even into plaster—are good to keep on hand in a range of sizes for items of varying weights, up to about 25 pounds or so. Larger items that must be wall-mounted will use larger fasteners; check with your helpful hardware salesperson about the type and size of fastener best suited to your walls and what you're hanging.

Keep a handful of tacks—the large-headed thumbtacks and small-headed metal tacks—for hanging other small items.

## Hold It: Containers

Even when you're not using liquids, a household bucket makes a good tote for tools and supplies for any DIY job. Get a sturdy, good-quality plastic model with an equally sturdy handle for those times when you do transport water (at about 7 pounds per gallon, water can be unwieldy to carry).

Also keep a supply of small lidded containers for those occasions when you need to carry around fasteners, small quantities of liquid, or other little items that can easily go astray.

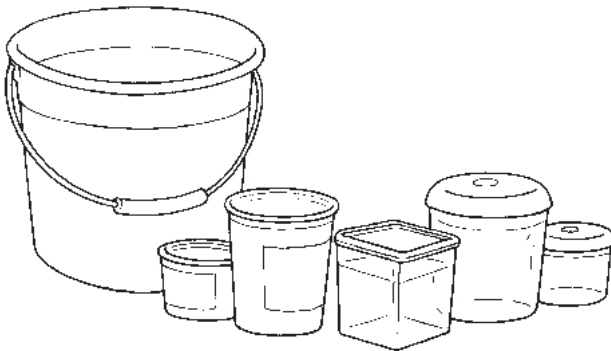

*A variety of containers.*

## In Case of Small Water Emergencies

Between your tool kit and the supplies I've already described, you're covered for a lot of different small breakdowns in the house. And here are two more things you shouldn't neglect.

Plumbing leaks and backups are the most potentially damaging of the small home repair crises you will encounter day to day. Of course, you can always just shut off the household water at the main (see Chapter 4) and wait for the plumber. But a stopped sink or toilet, or a pinhole leak in a pipe, can be addressed with a couple of simple and inexpensive items.

A plunger, also known as a “plumber’s helper,” will help you clear many types of clogs in your waste water (drain) system; you can find out how to make these fixes in Chapter 10.

*Plunger.*

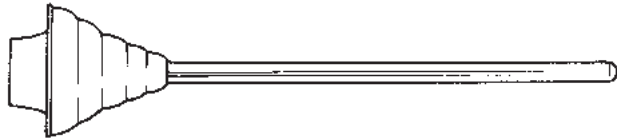

For tiny leaks in supply pipes, you can buy a package of do-it-yourself gasket material (cork or rubber is good), and a couple of adjustable hose clamps that fit your pipe (metal supply pipe is usually  $\frac{1}{2}$ " ) to hold back the water until your plumber arrives. This fix is also covered in Chapter 10.

*Pipe leak repair supplies.*

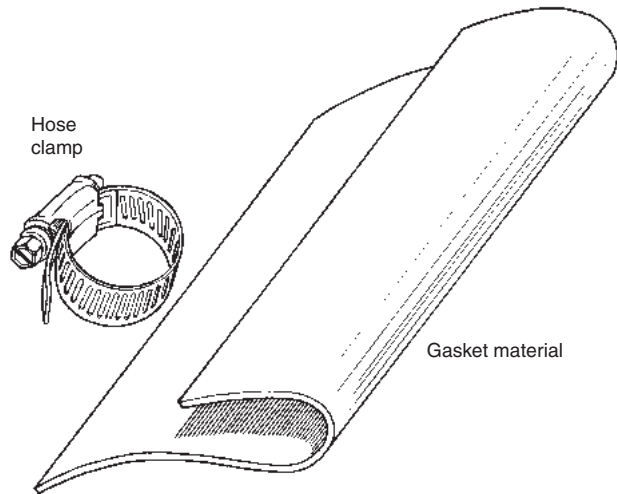

## Storing Those Leftovers!

Whenever you or a pro do a home improvement project in your house, there's usually material left over: extra tiles, extra paint or wallpaper, carpet scraps, or resilient flooring pieces.

In most houses, there never seems to be enough closets and cabinets to hold all our stuff; those DIY leftovers feel like just another pile of junk to deal with. So too often, the leftovers are thrown out or given away.

Even if you save that last half-roll of bedroom wallpaper, or the extra tile from the bathroom re-do, the tendency is to just throw the stuff in a box and put it anywhere out of the way where the box fits. The problem with that strategy is that you probably won't find it when you need it!

If you look through this book, you'll notice that many of the repair instructions call for leftover this-and-that. So do yourself a favor you'll thank yourself for later. Buy some clear plastic storage containers and keep the leftover stuff in those. Label the containers with what's in them and which room the leftovers came from. It's an easy system, sure to save time, money, and trouble down the road.

In the case of leftover paint—great for touch-ups—you may not need the leftover half-gallon of the custom color in your living room ever again, but you might need a small amount. To have what you need to cover a future minor repair, save a half-pint or pint in a clean, airtight container; label it with the room, paint brand, color name, and color number. You'll be glad you did. Custom colored paint is usually available in gallons only, a big expense and a big waste if you're just doing touch-ups after a small repair.

Check with your local waste removal carrier (private or municipal), about the rules for paint and solvent disposal in your area. Usually, you cannot throw these substances away in the regular household trash pickup.

When you finally move on to your next place, you can give the leftovers to the next owners as a housewarming present. Having replacement parts is always handy!



### Ounce of Prevention

Take care not to store certain liquids—like paint or solvents—in your home's hot spots: near a heat source or in attics. Always check the original label; most DIY liquids belong in cool, dry places, with their lids tightly secured.

*Closed containers for storing leftover materials.*

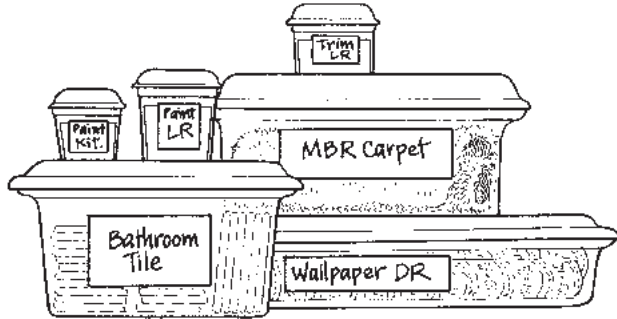

### **The Least You Need to Know**

- ◆ DIY supplies and materials deserve a dedicated place in your house. Find one that's convenient for you and secure for all family members, including pets.
- ◆ A well-stocked supply closet includes at least one lubricant, a liquid adhesive and DIY tape, a selection of fasteners, and stuff for cover-ups and clean-ups.
- ◆ You'll appreciate the value of a plunger and a pipe repair kit after your first night, weekend, or holiday plumbing emergency, when pros are hard to find.
- ◆ Leftover DIY stuff that you organize and save is destined to be very helpful later.

# Chapter 4

## A Map of Your World

### In This Chapter

- ◆ Locating the main controls for the systems in your house
- ◆ Starting and stopping water flow, whether it's from a well or from an outside supplier
- ◆ Controlling your gas supply, and what to do if you suddenly smell gas
- ◆ Safe handling of your electrical panel
- ◆ Creating a personal home workbook

You need a lot of information to run a house. Unless you're a person who leads a very simple life, your home has a plumbing system, an electrical system, and maybe a gas supply to heat your home or hot water. If you're out in the country, you probably have a water well and a septic field, too.

Not to mention all those helpful appliances! They have plugs, hoses, switches, gaskets ... a whole bunch of parts that may someday give you grief. And when one of them breaks down, you discover that you don't really remember where you tossed that use and care manual; it might have come in handy, if you could find it!

This chapter will help you figure out how to get more control of all the equipment that helps you run your home. You'll get some ideas about how to organize everything you should know about your house in a single location. It will make taking care of things a little bit easier.

## The Main Thing: Your Home's Power Centers

The least convenient time to search for the controls for your home's water, gas, and electric service is when something suddenly goes very wrong. In the case of a gas leak, not understanding where and how service comes into your house can be life-threatening. So listen up!

Go to the stationery store, or with your own creative know-how, make labels or tags that say "Main Shutoff" for the primary gas and water valves in your house, as well as for the main electric service panel. Then follow the directions below and on the following pages so you can find, mark, and use them.

Basements are not always well-lit or easy to negotiate, so you'll want to take along a flashlight for this activity. If you don't have a basement, your utilities may be in a dedicated closet, or small room close to where the wires and pipes enter the house. Unless it's well lighted, you'll need a flashlight here, too.

## Finding the Flow: Your Water Supply

If your water comes into the house from a municipal or private water company, there will be an outside shutoff for the water as it comes from the main pipe under the street onto your property and into your house. Don't concern yourself with this control, as the shutoff can only be made by water company employees with special tools. (You should call the water company if an unusual flow of water near the street causes you to suspect a leak in the larger system.)

Find the water meter on the outside of your house; then look inside in a corresponding area for the water supply pipe that comes into the house.

The water control in an older home is often a gate valve with a round handle. In newer homes, the straight-handled ball valve has replaced the old-style control.

The gate valve works like any round handled faucet; a clockwise turn (or turns) shuts off the water supply, and counterclockwise turns restore the flow. There's no need to play with it if you don't need to shut off the water supply. When you do need to turn it off, if it's difficult to turn, get your can of lubricant and give the valve a little squirt. If it still won't budge, leave it alone and call the plumber.

Ball valves work differently. They are sturdy and long-lasting, and the best replacement for a worn gate valve. When the water supply is flowing, the handle is in-line (parallel) to the pipe. A quarter-turn (90°) shuts off the water. The ball valve turns off in only one direction, so don't try to force it the wrong way.



*Gate valve.*

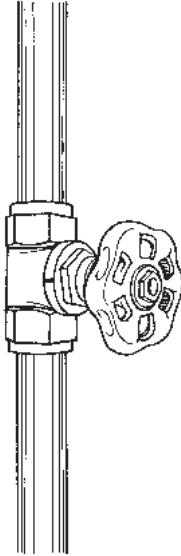

*Ball valve in "on" position.*

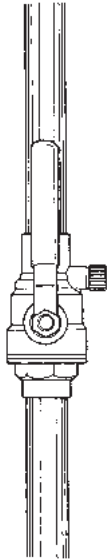



### What Pros Know

Ball valves are a lot easier to operate than gate valves. Because main controls are operated infrequently, an old gate valve can become very hard to turn on and off. If you've got one of these antique numbers, and it's looking worn, consider having a plumber replace it the next time you hire him for another job. It's a nasty problem when the main gate valve starts leaking!

Once you've found your main water control, label it "Main Water Shutoff." To make it easier to see in a dark basement, you might want to mark it with fluorescent tape.

## Oh, Well

If you live in the country and do not have municipal water service, you'll need to know where your well is located, and figure out where the supply pipe enters your house. The shutoffs will look the same as those for metered service, except that you don't have a meter. Instead, you've probably got an electric pump, positioned deep in your well, that pumps water into holding tanks, and from there into your house.

A well supplies the water for my own house, but fixing the pump is not my kind of work. And the pump always decides to give us trouble on the holidays, when our well service man is otherwise engaged. Fortunately, these pumps are built to last, and breakdowns don't happen often.

However, if there's a water leak in your house and you want to stop the flow of water, there's an additional water/off option. You can use the main shutoff at the pipe, just as you would shut off the municipal supply, *or* you can go to your electrical panel (see more about this control later in the chapter) and shut off the circuit that controls the well pump.

## Where the Well Water Goes

It has to go somewhere, and if you have a private water well that serves your home, chances are your wastewater goes to a septic tank and septic field on your property.

When you bought your house, if you have a septic system you should have gotten a map showing the location of your tank and field. If not, one should be on file at your county Board of Health.

The good news about septic systems is that they work very well—until they don't. If you don't have a company to pump out your septic tank, you should get one and use their services at recommended intervals. (These intervals are based on the number of

occupants of your home; the Board of Health sizes septic fields based on the number of bedrooms.) Most septic service companies will put you on a schedule and call when you're due for a pump-out. Do not neglect this regular service!

A septic system is a mess to repair, if the waste (effluent) is blocked from leaving your house via the waste line. And a failed septic system is a huge expense to replace. So make friends with a reliable septic system service company.

## Your Gas System (Outside the House)

If you use natural gas for your heating system, hot water, clothes dryer, or stove, your supply also comes in from the street through a pipe that registers your usage at a meter outside the house. Just before the gas meter, you will see a shutoff valve that usually looks like a small, rectangular handle. When this control is parallel to the pipe, it means the gas is flowing. When it's turned perpendicular (90°) to the gas pipe, the gas is turned off.

The outside gas main control requires a wrench to turn it on and off. Like other outside controls for municipal and private utility service, in most cases the outside gas shutoff should only be turned on and off by gas company personnel, or the fire department.

### If You Smell Gas

When natural gas comes out of the ground at its source, it has no color or smell. Companies that supply gas to consumers and businesses add the very noticeable odor of rotten eggs to gas so that a leak is easy to detect.

This is very important. If you should ever smell a *strong* odor of natural gas, do not use any devices that might make a spark. Light switches, phones, even turning on a flashlight could ignite the gas and cause an explosion.

Leave your home immediately and take anyone else in the house with you, including pets. Once you're *safely out of and away from the house*, call the gas company or 911 from a neighbor's house or your cell phone, if you've got one.

### Other Gas Controls

There is sometimes a gas supply main control inside the house, in addition to the valve outside before the meter. It should be located close to where the gas supply comes into the house. This one (if you've got one) is usually a ball valve, operated

in the same way as a water supply main ball valve: parallel to the pipe means the gas is flowing, and perpendicular to the pipe means the gas is off. Label this one “inside main gas control.” Like the water supply valve, you may want to use fluorescent tape on the label so it’s easy to see in a dark space.

*Inside main gas supply control.*

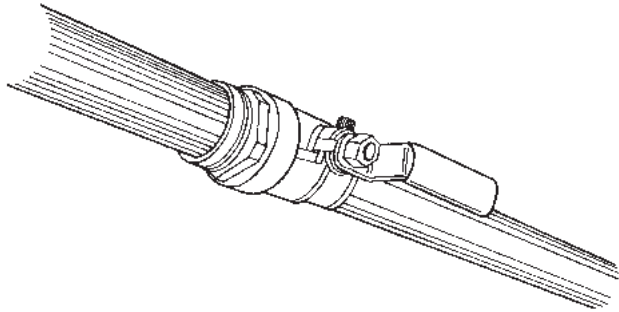

There are also individual controls for every gas appliance in your home. Usually they’re located on the metal supply pipe, where it connects to the flexible pipe that supplies the appliance. While the gas *supply stops*, as they are called, may have a slightly different look than the main supply ball valve, they work the same way.

## def•i•ni•tion

**Supply stops**, also known as supply valves, are on/off controls found along household utility supply lines, managing the flow of gas or water to individual fixtures and appliances. Gas supply stops usually work on the principle of the ball valve, with the position in line with supply pipe indicating “on,” and a position perpendicular to the pipe indicating “off.” Supply stops for water fixtures usually work by turning the stops clockwise for shutoff, and counterclockwise for the open/on position. (Remember: righty, tighty; lefty, loosey.) The handles of water supply stops are usually round or oval, but sometimes older stops look like the gate valve pictured earlier in this chapter.

*Propane* is a gas derivative of the production of petroleum and natural gas, which is then compressed into a transportable liquid. Many rural homeowners who do not have access to natural gas pipelines use propane to power their gas appliances. Propane is stored in a tank outside the house and piped inside. There is a shutoff at the tank (reserved for the use of the propane service that you pay to keep the tank filled). Inside the house, appliances using propane will have supply stops at the juncture of the supply line and the appliance’s gas line. These stops will work the same way as supply stops for natural gas.

Propane is just as flammable as natural gas, and is treated to have the same rotten egg odor if it leaks into the air. If you detect the strong smell of gas, use the same extreme caution as you would with natural gas. Don't fool around, get outside quickly, and call for help.

## Your Electric Service

Before you reach for your flashlight to go figure out your home's electrical system, remember that you need to use common sense when working around electrical wiring. Do not even touch the electric service panel if there is standing water in the room where it is located. Don't use both hands to explore the panel; keep one at your side. Touching both hands to the panel completes a circuit (you!), and you don't want to be the recipient of current gone astray. Take care!

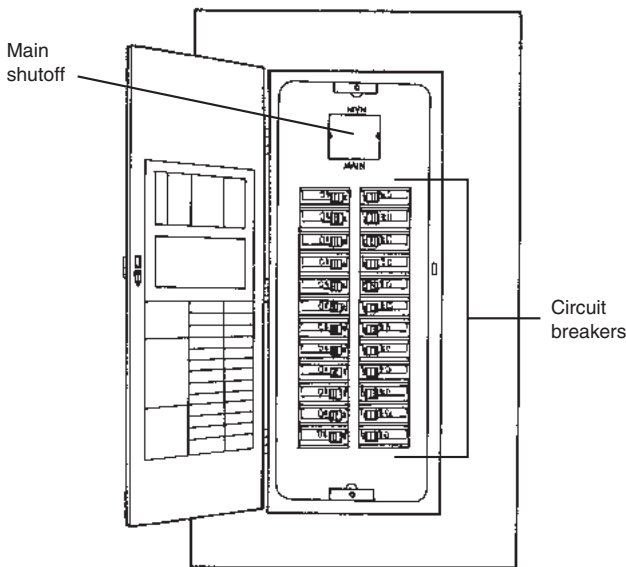

*Electric service panel: circuit breaker panel.*

Depending upon how old your home is, your electrical controls will be located in a metal box containing fuses—which look like tubes or glass-topped plugs—or toggle switches, called *circuit breakers*. The toggle-switch type of circuit breaker meets current electrical code requirements and has been around for more than 40 years; you'll find fuses in an older house. This metal box is connected to the large insulated wires

that come into your house from the electric meter outside, and the electric company's power grid beyond it. The box, called an electric service panel, or "breaker box," is control central for the electric current that powers all the switches, receptacles, and light sockets in your home.

*Fuse panel (aka fuse box).*

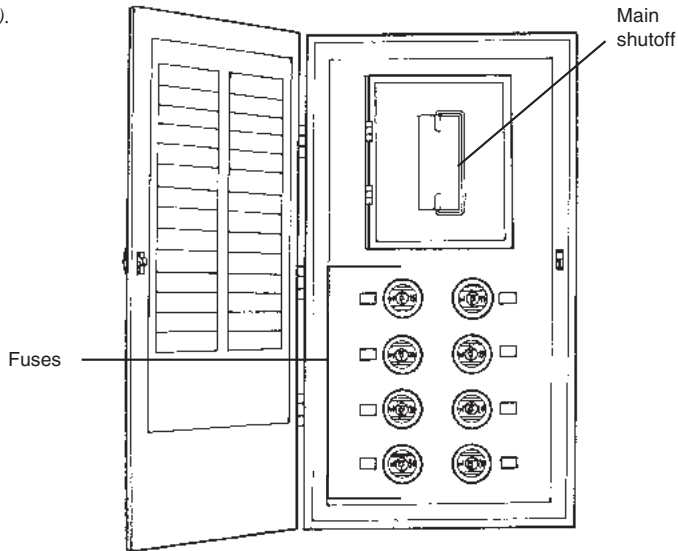

## def•i•ni•tion

A **circuit breaker** is a device that stops the flow of electricity in a circuit if there is too much current for safe operation. Both the toggle switches and the fuses used in the two types of service panels act as circuit breakers, but only the toggle-switch type are commonly referred to as circuit breakers. Toggle types move automatically to "off" in an overload. Fuses "blow"; that is, the metal strip inside the fuse melts from the overload. You will have to replace it with the same size and type of fuse.

If you have toggle-type circuit breakers, the main control that turns on and shuts off all the electric current for the house is often (but not always) located at the top of the service panel, above all the other circuit breakers. Sometimes, as in the previous illustration, the main toggle switch is enclosed with a little access door; open the door, and flip the switch to "off" to shut off. If you have fuses, you'll find the main fuse at the top of the box. The main toggle in the circuit breaker panel will usually have a number on it, indicating the type of service coming into your home. This

service is measured in *amps* (amperes), so you will usually see the main toggle marked 100, 150, or 200.

Occasionally the main control for the service coming into your house will be located in a different metal box, and sometimes a different location, than the service panel containing the toggle switches or fuses for separate circuits. If you can't locate the main control—if it's not obvious—then you need to call an electrician. They may be nice enough to direct you to the main by instructing you over the phone, or you may need to hire one to explain your system. Either way, you're talking about electricity, so knowledge is much safer than ignorance here.

If you're lucky, someone has taken time to clearly identify all the circuits in the house for you; each toggle switch or fuse is labeled with the rooms, switches, and receptacles, or appliances that each breaker or fuse controls. If not, or if they're labeled ambiguously (for example, the previous owner marked a switch "Grandma's bedroom," so you can't identify it), it's a good idea to create a "map" of all the circuits in your house, then label the switches or fuses in the service panel or fuse box. When the lights shut off from a current overload in the future, you'll be glad you took the time to do this. You'll find instructions for creating a circuit map in Chapter 13.

## A Workbook for Your Home

When something goes wrong with the workings of your house, you'll find a lot of solutions in this book. But as you read, you'll find that some instructions contain the words "often," or "usually," or "consult your owner's manual." That's because every mechanical system and appliance may have parts or works that diverge from a certain reliable standard. Perhaps the switch you're looking for is on the back of the appliance, not the front, where it is on 90 percent of the models most people see.

The more information you make available to yourself about your house, its systems, and all the appliances and conveniences it holds, the better able you will be to troubleshoot problems, judge which ones you can handle, and quickly assign the tough chores to the pros.

So, put it all together. Get yourself a 3-ring notebook with a wide spine (3 inches or more). The D-ring style holds pages flat most easily. If you have a lot of notebooks, buy this one in a color you can find quickly (red or yellow are highly visible). Fill it with those clear plastic sheet protectors—the kind that hold multi-page documents. If you want to be really organized, buy a pack or two of dividers, and label them with the name of each room and section of the house: kitchen, baths, bedrooms, living room, basement, attic, garage, and so on.

What will you put in this notebook? Let me give you a few ideas of basic things you can keep in it.

## **Appliance and Fixture Use and Care Manuals**

Not every equipment problem signals the need for a repair or a service call. Sometimes you may have forgotten to turn a switch on or off. Maybe you've tried to start the device improperly. Use and care manuals contain instructions for assembling (when necessary), starting and stopping an appliance or fixture, and using it properly and safely. This handy guide usually has an illustrated diagram of the device, complete with the names and location of all its parts, including the label that will provide the model and serial numbers for your specific piece of equipment.

Often there's a handy section on troubleshooting—that is, strategies for figuring out what's wrong if something's not working properly, usually followed by the manufacturer's 800 helpline number or website URL. In addition, you'll find a listing of authorized service representatives.

These manuals are great. If you've got them all in a drawer somewhere, transfer them to the sheet protectors in your notebook. If you're really organized, file each one behind the divider you've labeled with the name of the room where the equipment is located.

If you're not very organized, now's the time to start. Those little instruction booklets can save you a lot of time!



### **What Pros Know**

Can't find the use and care manual for an appliance or piece of equipment? If you can locate the manufacturer name, model number, and serial number (usually listed on a label somewhere on the device), you may be able to find the manual from the manufacturer's website. This is very possible if your equipment is fairly new, less so if it's more than five to seven years old. Once you find the manual online, you can download and then print a hard copy of it to file in your workbook. (Be sure to have plenty of printer paper and an almost-full ink cartridge before you try to do this.) If an Internet search proves fruitless, try calling the manufacturer's 800-number consumer help line.



## Receipts and Manufacturer's/Dealer's Warranties

When something breaks down not long after you've purchased it, it may be covered for service or repair by the existing manufacturer's warranty, or a warranty you purchased from the retailer when you bought the equipment. File your purchase receipt and a copy of the warranty with the use and care manual. If your device is covered, your tool kit can stay in its storage location. In fact, *never try to repair something yourself when it is still under warranty; you'll void the warranty.* Call the number listed on the warranty; or call the dealer, if you purchased the warranty through the retail store.

Some manufacturers guarantee their equipment for life. I never believed I'd take someone up on this promise, and was doubtful that what was promised was indeed true (I can be cynical). But most companies who make this pledge turn out to actually mean it. When my very expensive, guaranteed-for-life kitchen faucet came apart after just a year, I called the manufacturer, and two days later, they had a new one delivered to my door!

Now, there must have been some serious flaw in the design (or in the user—me!) but the faucet broke again about two years later. And, true to its word, the manufacturer sent me another new faucet.

Make use of your lifetime guarantees! They'll save you money and time.

## Equipment Manuals or Schematics

Heating and cooling devices (furnaces, central air-conditioning units), water treatment units, and other big items that figure in the major operations of your home, may have been installed long before you arrived. In that case, you may be out of luck on obtaining a manual or a detailed drawing (called a schematic) that illustrates the equipment with labels for its parts. If you've got a drawing or manual, pop it in your workbook. It will help you when something goes wrong with your big systems. Down the road, if and when you sell the house, the buyer will appreciate this documentation.

## A Circuit Map of Your Home

If your circuits are clearly labeled, copy the information on a piece of paper to keep in your home workbook. If they're not, you should go to Chapter 13 as soon as you can and learn how to create this valuable map.

## Service Records

When you do a repair on any equipment in your home, save the receipt. Make sure you or the professional service person notes the scope of the work and the date it was done. That way if a repair fails you've got a record, and you'll know if you've got a chronic problem with something in your house.

File these records right behind the manuals and warranties you keep for the equipment.

## Other Workbook Items

When you do a home improvement—install new carpet, paint a room, upgrade your kitchen—you can put the records and specifications, receipts, and manuals in the appropriate section of your workbook. This is particularly helpful when you're looking to match paint or other materials to do a repair later on.

If you take the time to start it, and use it as information central for all the important components of your house, your personal home workbook will save you hours of time, and probably lots of money!

## The Least You Need to Know

- ◆ The proper time to find out where to find the controls for your water, gas, and electric service is before there's a problem—that is, *right now*.
- ◆ Label all the main shutoffs to make them easy to see and read.
- ◆ If you can't locate your main controls, don't hesitate. Call a pro who can help you find them.
- ◆ For easy reference, for saving time and money, and for troubleshooting problems, create a home workbook to keep your manuals, diagrams, and service and repair records in one place.

# Part 2

## Skin Deep: Repairing Surfaces and Openings

Walls, floors, ceilings, stairs, windows, and doors are the first things you see when you look at a house. If the heating system and appliances are like its vital organs, a home's surfaces are like its skin. And although neglecting surfaces will not usually make a house fall down, they're components that everyone notices.

Unfortunately, like our own skin, these parts of the house show signs of aging and the bruises of long and continued use. Your house may have little indicators of time passing—nicked walls, bumpy floors, doors and stairs that squeak and sigh. It's inevitable, just like wrinkles.

But if you're not yet ready for the face lift—a full-tilt, expensive renovation—there are a lot of small repairs and cosmetic fixes that will brighten this top layer of your house, and help you enjoy it more. Part 2 gives you lots of ideas and plenty of instruction.



*"Make my day."*

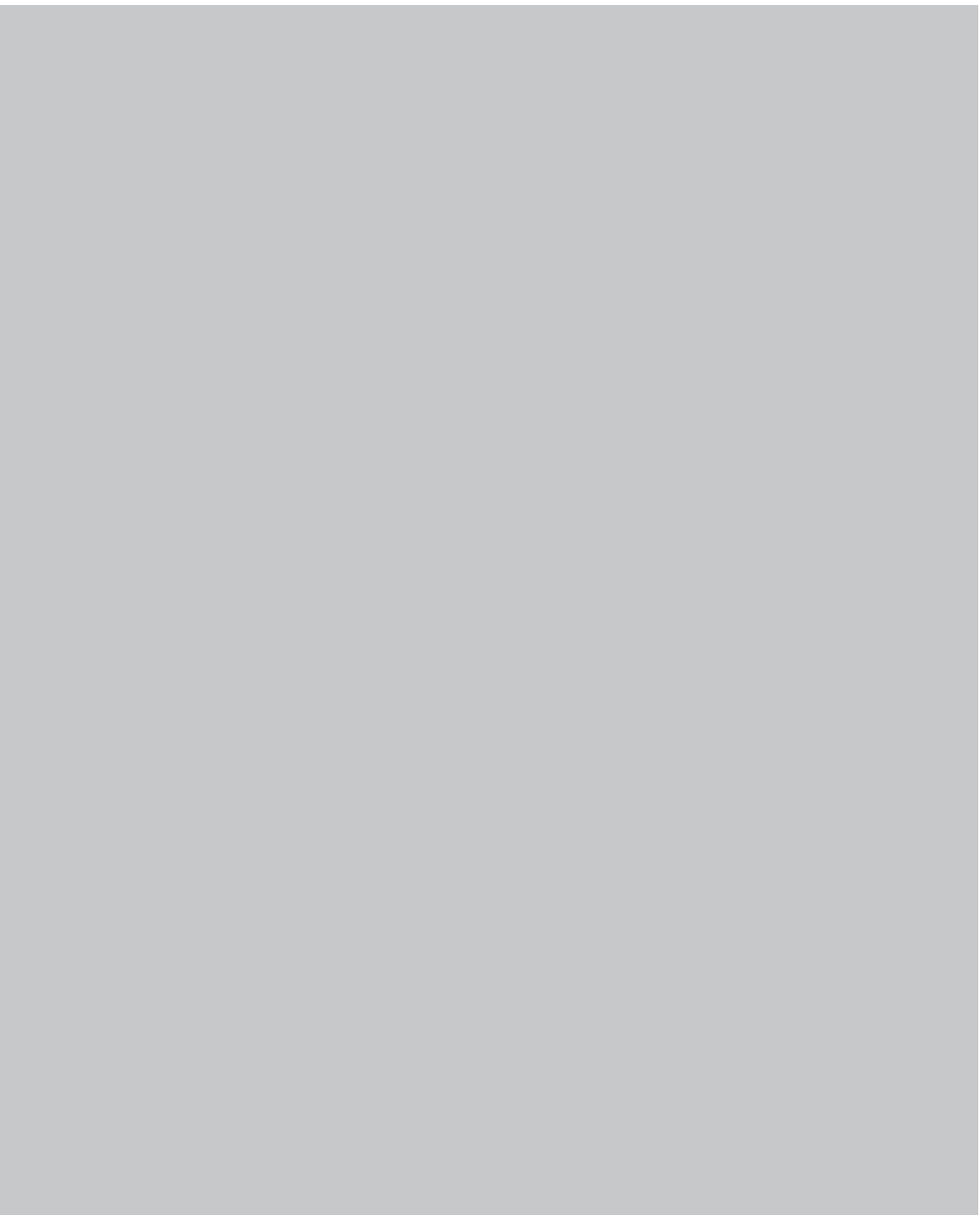

# Chapter 5

## Walls: From Trash Talk to Smooth Talk

### In This Chapter

- ◆ Making minor repairs to drywall surfaces, and patching a larger hole
- ◆ Repairing small cracks in plaster
- ◆ Replacing grout, and removing and replacing a cracked or broken ceramic tile
- ◆ Making minor repairs to wallpaper

Unfortunately, your walls *do* talk. Every bump with a furniture leg, hit with a hockey stick, and bounce of a ball where it shouldn't be can make a mess of your nice, smooth walls. Sometimes, a scuff will wash away with soap and water, but sooner or later, deeper evidence of close encounters of the worst kind will need treatment.

In this chapter, you'll learn to work with joint compound and other soft stuff: grout, tile cement, glue, and other materials to make beat-up walls look clean and new. And working with all this goop may bring back nice memories of your sandbox days!

## Minor Drywall Repairs

Drywall is the most common type of base wall material, and what you'll usually find in houses less than fifty years old. It is made by sandwiching a gypsum core, which is fire resistant, between layers of paper. Sometimes known as Sheetrock, wallboard, or gypsum board, this material is also made in a water-resistant variety for use in damp areas such as basements and bathrooms.

You may not want to fix dings, dents, or popped fasteners every time they happen; if you've got an active family or an enthusiastic pet, little nicks and dents are bound to occur frequently. But sooner or later, your walls will get that tired, worn-out look. If possible, wait until your room is ready for its next paint job.

These little repairs are easy to do but take time because there are several steps. Between each step, you must wait for the patching medium to dry. Normally this means waiting 8–12 hours (or overnight) to go to the next step. Unless you're that rare bird with time on her hands, make all the wall repairs in one room on the same weekend, or successive days, so that all the fill-ins dry in one waiting period, are primed at one time, then painted at one time.

With little repairs, work gently. A bold, heavy hand will make a small flaw larger.



### Ounce of Prevention

Be sure to wear safety goggles and a dust mask whenever you sand to protect your eyes and lungs. Maybe you think it's wimpy to protect your eyes, nose, and mouth for simple, small repairs. But I think my vital parts are worth protecting, no matter how few small particles are flying. Over time, little particles add up to bigger problems, and tiny crumbs of plaster in the eye can create a big problem. So be safe when you sand! I also hate sweeping and dusting, so the newspapers or drop cloth are my constant home repair sidekicks; they're much cheaper than a cleaning service.

## Repairing Dings and Dents

You'll need the following:

- Sanding block or sandpaper (80–100 grit and 120–150 grit)
- Utility knife
- Clean sponge or cloth

- Putty knife
  - Joint compound
1. Lay newspaper or a drop cloth below the repair site to catch debris. Put on safety goggles and a dust mask when you sand to protect your eyes and lungs.
  2. Using the 80–100 grit sanding block or paper, *lightly* sand the dent to remove little flecks of the drywall or paint that hang on the surface.

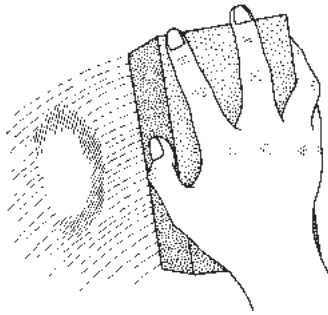

*Sand the dent.*

3. *Gently* cut away any torn pieces of the drywall that remain at the repair site with a utility knife.
4. Wipe the dent with a damp cloth or sponge to remove any bits that remain in the dent area.
5. With the putty knife, fill the dent with joint compound, and smooth the surface of the repair. Wipe off and clean the putty knife. Allow the repair to dry (usually overnight; see joint compound package directions).



*Fill the dent.*

6. When the repaired surface is dry, sand with the fine (150-grit) sandpaper.

If the surface looks rough or bumpy, or if any of the dents can still be seen, you'll need another cycle of compound application/drying time/sanding. If you're satisfied with the repair, wipe it off with a damp cloth or sponge, or vacuum the repaired area using the brush tool. You are ready to prime and repaint.



### What Pros Know

When applying joint compound, your result should blend into the surrounding wall. While the recesses caused by denting and nicking should be filled, you don't want the surrounding walls to look like a relief map of the Rockies. Aim for a finished repair that is as flush to the intact drywall surface as you can make it. Think of the compound as a thin glaze, not fluffy frosting!

## Popped Nails

While most pros now opt for screws and power drivers to install drywall, nails used to be the fastener of choice for attaching wallboard to the wall studs (lumber that creates the frame for the walls). A drywall/wallboard nail (they may be called by either name) has little rings on its shank and a flat, round head. Even though they're designed to stay put, these sturdy fasteners do pop out from time to time. Here's how to keep them in their place.

You'll need the following:

- Claw hammer
- Drywall nails
- Putty knife
- Joint compound
- Sanding block or sandpaper (150-grit)
- Clean sponge or cloth

1. Lay newspaper or a drop cloth below the repair site to catch debris. Put on safety goggles and a dust mask when you sand to protect your eyes and lungs.
2. Hammer the nail back into the drywall so it's flush with the wall. With a second hit, create a small dimple in the wall around the nail. Don't pound hard; you want a dimple, not a tear. Then drive a second nail next to the first, to hold the popped one in its place, and create a second, overlapping dimple.



*Create dimple.*

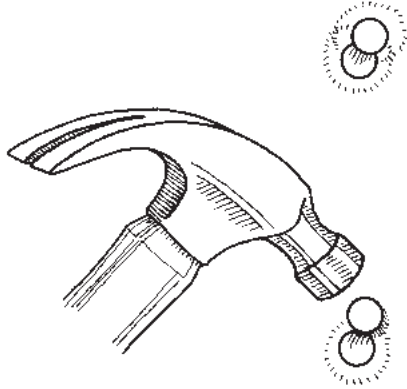

3. Using the putty knife, apply joint compound over the nail heads and dimples. Clean the putty knife and allow the compound to dry. When the repair is dry, sand the area and wipe off any remaining dust. You are ready to prime and repaint.

*Apply compound to dimples.*

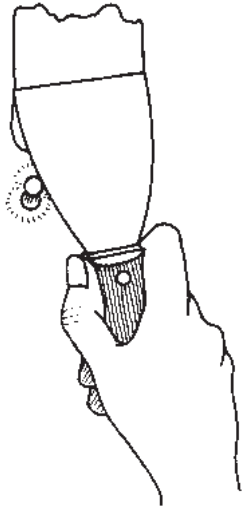

## Patching Holes

Oops! I know you didn't mean to put your hammer (or the shower rod, or some other object) through the wall, but there it is: a nasty-looking void in the drywall. It used to be that fixing this kind of damage meant ripping out a section of drywall between studs and doing a (very) labor-intensive repair. Hardware stores now stock a great invention for holes of relatively small diameter: a mesh patch you can place over the hole. It's got a sticky back that adheres to the intact wall surface around the cavity. These patches are available in sizes up to about 8 inches square.

You'll need the following:

- Utility knife
- Sanding block or sandpaper (80–100 and 120–150 grit)
- Mesh wall patch (about 2× the area of the hole)
- Tray to hold compound
- Joint compound
- Putty knife (4" or wider, depending on the hole)
- Clean sponge or cloth

1. Cover the floor with newspaper and place a drop cloth on the surrounding area to protect furnishings. (This job may raise more dust than the others!) Put on safety goggles and a dust mask when you sand to protect your eyes and lungs.
2. Prepare the surface for the patch. Use the utility knife to cut away any protruding or hanging pieces of drywall. You might also want to sand the edge of the hole gently with the coarser grit (80–100) sandpaper. The idea is to make the surface of the hole flush with the wall, not to make the hole bigger!
3. Peel away the backing paper from the mesh patch and center the patch over the hole; then stick it down, smoothing the edges.

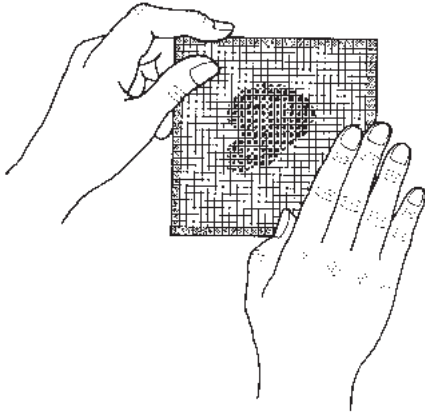

*Apply the mesh patch.*

4. Load your tray with joint compound. Use the putty knife to apply the compound over the patch. Cover the mesh area completely, applying compound beyond the borders of the mesh. Smooth on the compound from side to side, top to bottom, corner to corner. When you're finished, clean and dry the knife and tray.

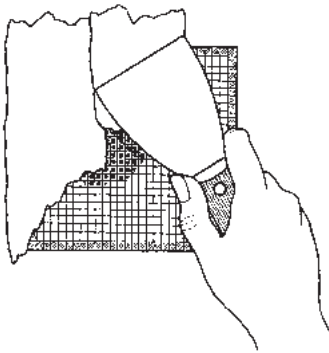

*Apply compound to patch.*

5. Let the repair dry—like other drywall repairs, this one will take 8 or more hours. Then sand the dried area with the coarse (80–100) sandpaper. Wipe away any dust with a damp sponge or cloth.
6. Apply a second coat of compound as in Step 4. Let the compound dry. This time, use the fine sandpaper (120–150), and clean up as before. You're ready to prime and paint.



### What Pros Know

Small flaws—dents, popped nails, and the like—can usually be covered with a 2" or 3" putty knife, and joint compound applied right from its small container. If you've got holes or a lot of imperfections to cover, you'll probably want a larger bucket of compound and a broader knife, 4" or wider, to cover the hole(s). To keep the compound from drying out, transfer the quantity you think you'll need into a tray (you'll find trays near the joint compound in the hardware store or home center). Then reclose the lid on the compound bucket to preserve the rest. Professional drywall installers work quickly, and waste neither time nor words. They call joint compound "mud," an apt description that saves two syllables!

## Loose Drywall Tape

Drywall seams are joined and sealed by means of drywall tape, now a nice, self-stick product that usually stays put. But the drywall seams in your house may be put together with the old, paper product. This sometimes lifts off, and you can smooth it down with a new strip of 2-inch drywall repair tape, then go over it with joint compound and your putty knife, just the way you repaired everything else in this section.

If the old drywall tape is lifting all over the place in a section of a room, or rooms, this may be an indication of a moisture problem behind the sheetrock, and that's not funny.

Moisture in the walls not only damages drywall. It could degrade insulation, cause mold, and on and on. If you repair lifted tape and the problem keeps popping up, call in a pro.

## Repairing Cracks in Plaster

Plaster is a beautiful wall surface; intact plaster has a smooth, hard finish that is beautiful to the eye and the touch. If you've got an old house, your walls may be covered with this material, which is traditionally applied in three coats over a layer of *lath* that is attached to the wall studs. But houses settle, and that's when the fun begins. Sooner or later, cracks and other defects may appear.

For all of us in DIY 101, the cracks are what we'll deal with. Bigger jobs are for the pros.

Spackling compound is a bit thicker than joint compound, and is good for repairing hairline cracks in plaster.

You'll need the following:

- ❑ Lever-type can opener
- ❑ Clean sponge or cloth
- ❑ Spackling compound
- ❑ Sanding block (150-grit)

## def•i•ni•tion

**Lath** is the foundation for plaster, or sometimes for tile. It is traditionally a framework of thin wood strips, or, more recently, wire mesh.

1. Lay newspaper or a drop cloth below the work area to catch debris. Put on safety goggles and a dust mask when you sand to protect your eyes and lungs.
2. In order for the compound to make a good bond with the wall and the underlying layer of plaster beneath the crack, a hairline crack should be opened to about  $\frac{1}{8}$ " wide. Do this by running the tip of a lever-type can opener (or the tip of the blade of a table knife) down the length of the crack. Brush away any crumbs of plaster that remain with a damp sponge or cloth.



*Open plaster crack uniformly.*

3. With your forefinger, push the spackling compound into the crack using smooth strokes until the crack is filled, end to end. The repair should overlap the wall slightly, creating a bond with the plaster.

*Apply spackling compound.*



4. Wash your hands, and let the repair dry (up to 24 hours; check the spackling compound package directions). When it's dry, if the patch seems to have shrunk into the crack, repeat Step 3, filling the indentation until the patch is flush with the wall, then let the area dry completely.
5. Sand the dry surface of the repair, and wipe away remaining dust. You're ready to prime and paint.

Because plaster is usually composed of three layers—a base coat, a second thicker coat, and a top coat (the beauty part), damage below the surface layer and beyond small cracks can be a tough DIY project. If you're patient, don't mind a *lot* of dust, and have plenty of spare time, see Appendix B for some sources of help for larger repairs.

You may prefer to call in a professional. Plasterers are artisans, but since drywall has so overwhelmingly replaced plaster in modern construction, masters of this craft are disappearing. It may take some time and sleuthing to find a good one.

## Grout and Tile Crackups

Attractive, quite sturdy, and easy to clean, tile is a great wall covering in bathrooms, on kitchen backsplashes, and anywhere moisture can settle. A sponge or damp cloth wipes away dust and grime. It's wonderful stuff!

Over time, though, the grout (cement filling) between the tiles can become dirty and start to degrade; little bits of grout can chip or crack, and then it's time to renew the

offending seams. If grout is falling like rain, you may want to call a pro. Doing a whole wall or a whole room could be more work than you bargained for.

Sometimes, bad stuff happens to good walls. A single tile will develop an obvious crack, or fracture from too many hits with a pot, or the vacuum cleaner. Replacement is fairly straightforward if you've got some leftover tile stashed away.

You'll need to remove the grout around the broken piece before you remove the tile.



### Ounce of Prevention

If the grout in the tiled areas of your home still looks good, a great little weekend project would be to seal it. Your local tile dealer stocks sealers that are easy to apply, and will protect the surface of the grout; just follow the package directions. If you seal the grout every couple of years, you may be able to skip this section for a while!

## Replacing Grout

Finding grout to match what's already there may be the hardest part of this small job. Before you start, chip out a little sample of grout from the crumbling area with a utility knife, and bring it to the tile store. If you can't find a perfect match, ask the tile dealer about grout dye, which is applied like paint, with a brush, to the replacement grout. You may find just the right shade to make your repair invisible.

Oh, and if you've got a match, after you take what you need, be sure to close the package containing the remaining grout. Store it in an airtight container, labeled with the color and where it is used in your house. Love those leftovers!

You'll need the following:

- Masking or painter's tape
- Utility knife or grout saw
- Grout to match what's already there
- Clean sponge or cloth
- Grout sealer

1. Removing grout will create some debris in the area below the damage; spread newspaper or a drop cloth in the work area. Put on safety goggles to protect your eyes from flying debris.

2. The surface of ceramic tile is vulnerable to scratching and chipping. If you're removing grout, or a cracked or broken tile, you'll want to mask the edges of the surrounding tiles with masking or painter's tape so the repair you're doing won't create more work!

*Mask around the repair.*

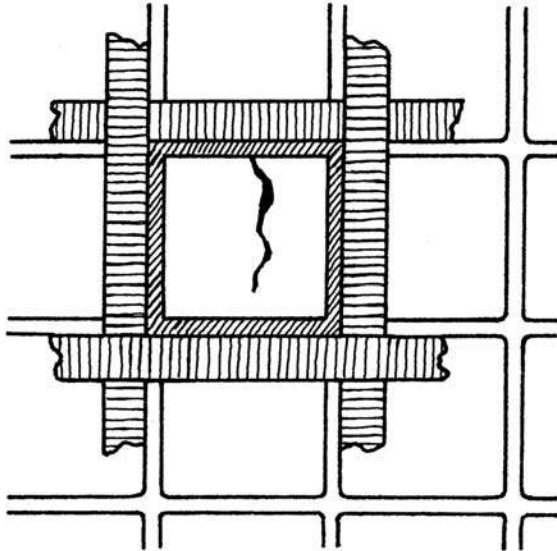

3. Remove the old grout with a utility knife or a grout saw. Ceramic tile is usually  $\frac{1}{4}$ " thick (or less) so work carefully and don't cut into the surface of the wall.

*A grout saw looks like a large utility knife with an offset handle. It is useful for cutting grout, especially if grout seams are wider than  $\frac{1}{4}$ ". A utility knife is fine for cutting narrower seams.*





4. Make sure the seams are free of the old grout, then mix the new grout according to package directions.
5. You won't be needing the masking at this point, so remove it from around the open seam(s). Apply the grout to the open seam(s); smooth it with your finger.
6. When the seams are completely filled and look smooth, you can wipe away any grout remaining on the surrounding tiles with a damp sponge or cloth. Let the grout dry, then seal it with a grout sealer according to package directions.

## Replacing a Ceramic Tile

If you're only replacing one or two tiles, you will only need a small quantity of tile adhesive, also called mastic. Bring the replacement tile with you, or ask the tile dealer when you buy a replacement which adhesive is suited to the job. Purchase that variety.

You'll need the following:

- Masking or painter's tape
- Utility knife or grout saw
- Metal straight edge
- Glass-cutting tool
- Nail set
- Hammer
- Cold chisel
- Putty knife
- Tile adhesive/mastic
- Replacement tile
- Wood block
- Grout to match what's already there
- Clean sponge or cloth



### Ounce of Prevention

If your broken tile is over the bathtub, you'll want to protect the surface of the tub from flying shards of tile. Cover the whole tub with a drop cloth. Bits of tile can be very sharp and downright dangerous when they become airborne. In addition to your goggles, protect your arms with long sleeves—button sleeves if they have buttons so loose cuffs won't be in your way.

1. Protect surrounding tiles with masking or painter's tape, and cover the floor around the work area with newspapers or a drop cloth. Put on safety goggles to protect your eyes from flying debris.

2. Remove the old grout; follow the instructions in the repair just described.
3. Using the straight edge as a cutting guide, and the glass-cutting tool, score the damaged/broken tile with an X mark, corner to corner on the diagonal.

*The glass-cutting tool is not only good for cutting glass; you can use it to score many hard, brittle materials.*

*Score the crack.*

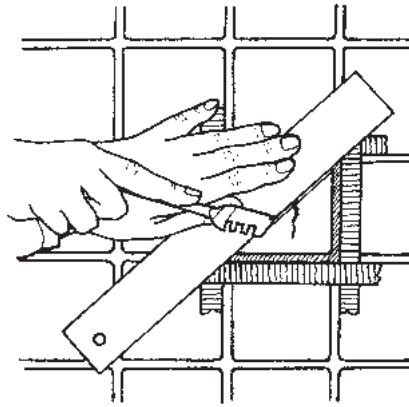

4. Position the nail set at the center of the X, and tap with the hammer to loosen the cracked tile.
5. Using the hammer and the cold chisel, carefully chip out the tile. Once you have gotten enough small pieces out, you can hammer the end of the putty knife (if it's got a metal end on the handle) to carefully work out the tile. Take care not to gouge the underlying wallboard. Hold the chisel or knife at an angle so that you're lifting tile but not denting or tearing drywall.

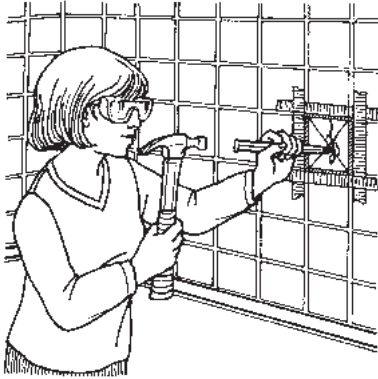

*Chisel out broken tile.*

6. When all the tile bits are removed, scrape out the remaining dried tile adhesive with the putty knife, also taking care to leave the underlying wall intact.
7. If you do make a gouge in the wall, go back to the drywall repair section of this chapter and make the repair. You'll have to wait for the compound to dry, then sand it and wipe away any remaining dust before you set the tile. (Remember to wear a dust mask when you sand.)
8. Using the putty knife (be sure it's clean and dry), "butter" the back of the tile with adhesive, and position it where the old tile was set. Wipe away any mastic that squishes up from beneath the tile.
9. Using a wood block to protect the surface of the new tile, hammer the block gently so that the tile is level with the surrounding work.
10. Hold the tile in place with masking or painter's tape while it dries (tape it up and down, side to side, to the adjoining intact tile work).

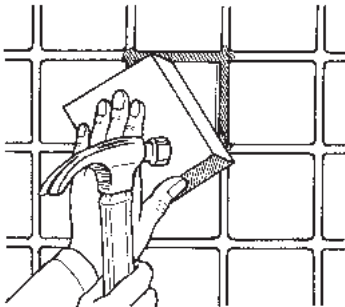

*Secure the new tile in place.*

11. Once the tile is set (adhesive should usually set for 24 hours; check the directions on the adhesive packaging), grout the seams around the tile, and wipe any excess grout away with a damp sponge.

*Replace grout.*

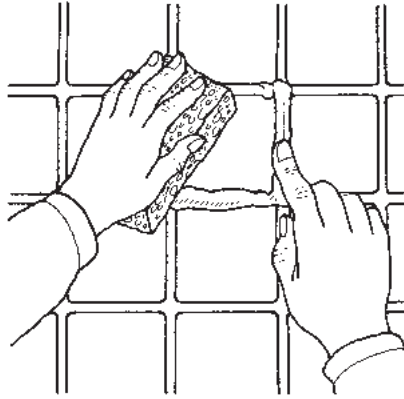

12. When the grout dries, apply a sealer according to package directions.



### **What Pros Know**

Uh oh! You have no leftover tile and there's nothing resembling it at the six or seven tile stores you've visited. (Did you check their discard piles of extras from old jobs? Don't forget to try.) If you're willing to sacrifice a few intact tiles, and the field (your tile wall) isn't too large, you can make lemonade out of this lemon of a dilemma.

Buy a few contrasting tiles that fit the color scheme in your room, or a few pretty art tiles that will complement the décor, and install them randomly. This replacement method will look like a design, not a repair, if done well. If this sounds like too much work, it won't take a pro long to replace a few tiles with substitutes, and the price will beat a complete retiling.

## **Minor Wallpaper Repairs**

After he graduated from the crib to a big-boy bed, my son lulled himself to sleep by picking at the wallpaper where his bed aligned with the wall. Cleverly, he did this below the level of the mattress, so I didn't notice until he had removed a fairly large patch of paper. To give him an alternative sleep aid to peeling wallpaper, we went shopping for a new fuzzy stuffed friend, and then I learned to patch. Fortunately for

me, the paper was a simple grid pattern; it was easy to line up the pattern and cut a patch along the grid lines. And my son loved Jerry, his new bear!

Even though you can return unused rolls of wallpaper and get a little money back, save at least one roll of leftover paper from any wallpaper project for unexpected mishaps, and store it with your other leftover supplies. Most wallpaper patterns go out of production after a couple of seasons, and if you've got a tear or hole in a prominent position that you can't cover with a hanging picture, you will regret being penny-wise!

## Bursting Those Bubbles

Unlike popping balloons, getting rid of air bubbles beneath wallpaper is a delicate maneuver.

You'll need the following:

- Utility knife
- All-purpose glue
- Toothpick
- Clean sponge or cloth

Carefully make a slit in the bubble and press it flat with your fingertip. If it won't stay down, put a little all-purpose glue on a toothpick, and carefully spread the glue underneath the lifted area. Press down, and wipe away any excess glue with a damp sponge.

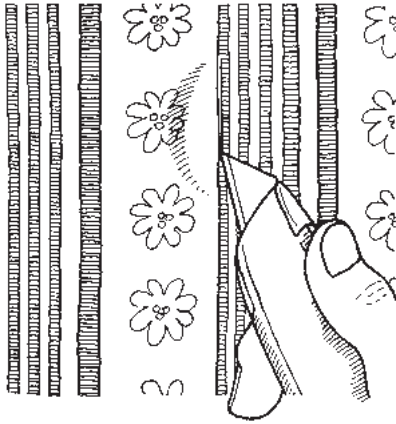

*Flatten a wallpaper bubble.*

## Flattening Flappy Seams

A good paperhanger takes care to match and flatten each strip of wallpaper so that the pattern—not the strips—are what you see when you walk into the room. Over time, the adhesive that once kept the edges down may dry out sufficiently that the seams begin to lift off the wall in places. And these little “lift-offs” can tear if someone brushes against them. A little first aid will keep your seams straight!

You’ll need the following:

- All-purpose glue
- Toothpick
- Clean sponge or cloth
- Wallpaper seam roller

As with the burst bubble, put a little glue behind the tear or the lift. Use a toothpick for gluing very small lifts. Press down, making sure the repair lines up properly with the adjoining pattern. Wipe away any excess glue that blobs out from under the repair with a damp sponge. Roll the seam with the seam roller for a neat, flat finish.

*Glue a wallpaper seam.*

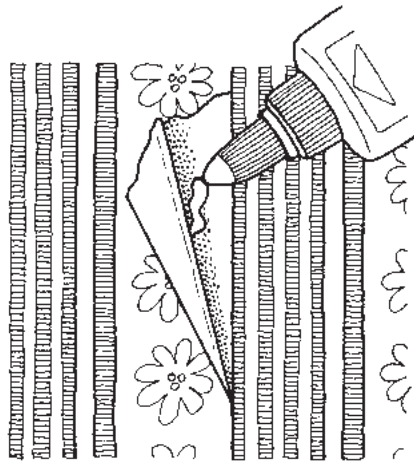

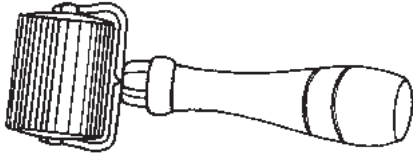

*A wallpaper seam roller will glide over your repair without biting a snag. It's also great for smoothing anything else you have to glue and flatten.*

## Patching a Torn Section of Wallpaper

That leftover roll of wallpaper is key to this repair. You'll need to make your patch line up with the existing paper, to make it less visible. It's best if the corners of the patch wind up inside the pattern, rather than on the plain background of the paper, so the repair is less visible. If the paper is a very busy pattern with little or no plain background, the corners should disappear nicely.

You'll need the following:

- Utility knife
- Blue painter's tape
- Straight edge
- Putty knife
- Wall sealer (for repair area)
- Bucket of lukewarm water
- Sponge
- Leftover matching wallpaper
- Wallpaper adhesive, or a shallow pan of water
- Brush for applying wallpaper adhesive, if necessary
- Wallpaper seam roller



### What Pros Know

Dipping it for about ten seconds in a pan of water activates the adhesive on pre-pasted wallpaper. Unpasted wallpaper is applied with wallpaper paste. Which kind is yours? Sometimes the manufacturer will tell you by printing the information on the backside of the paper. If you can't figure it out, dip a scrap of paper in water and see if it will stick to a wall surface. (Unless you want to keep it there, remove immediately after checking and wipe away the residue with a sponge!) Expensive designer papers, meant to be installed by pros, are often unpasted. If you're still in doubt, bring a scrap to the wallpaper store and ask.

1. Spread newspaper or a drop cloth below the work area to catch debris.
2. With the utility knife, remove any bits of wallpaper that are hanging loose. Cut a piece of wallpaper from your leftover roll that covers the torn or damaged area with a generous border around it.

*Cut the patch.*

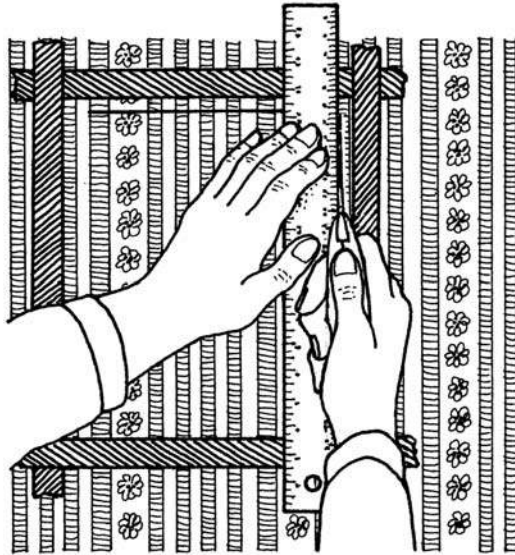

3. Carefully match the edges of the patch to the existing wallpaper, and tape it flush to the wall with blue painter's tape.
4. Using the utility knife and your straight edge, cut out a square or rectangular patch inside the taped edges that also encloses the torn area. You will be cutting the patch and scoring the existing paper at the same time. Take care not to gouge the wall. (If you should slip, you can always repair the underlying drywall with the skill you learned earlier in this chapter!)



5. Set aside your newly cut patch for the moment. Dampen the scored area around the torn area and use the putty knife to scrape away the wallpaper. You may have to apply warm water to the paper and let it soak for a few minutes to make removal easier.

If your old paper is strippable (it may say so on the back of the paper), you can just lift the corner of the paper with your putty knife and pull it back, holding the paper at a sharp 10° angle. Peel *carefully*.

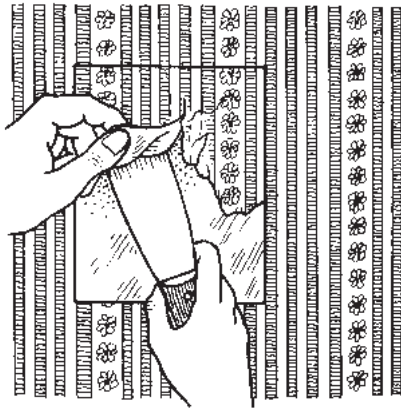

*Remove old paper.*

6. When all the paper is removed from the area you will patch (with your “custom fit” replacement), apply wall sealer (from the wallpaper store; ask the dealer) according to package directions, and let it dry.
7. If you’re using a prepasted wallpaper, dip it in water and then install it over the opening you’ve prepared, taking care to line up the pattern and the seams. Use the sponge to wipe away excess moisture. (If using unpasted paper, apply adhesive to the back of the patch according to directions. Wipe away any excess adhesive from the edges of the repair.) Smooth the paper from the center to the edges, taking care to keep the pattern in line.

*Install the patch.*

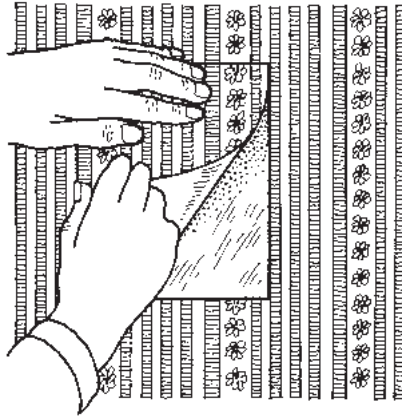

8. When you're satisfied with the fit, run the seam roller along the edges for a nice, flat edge. Let the patch dry.

## **The Least You Need to Know**

- ◆ Wall repairs take time because many patch products dry slowly. The good news: you don't have to watch! Do something else while you wait.
- ◆ Save and label leftovers from renovation projects. You never know when you'll need an extra tile or piece of wallpaper.
- ◆ A heavy hand in wall repairs makes more work. Light and easy does it!
- ◆ Always protect your eyes, mouth, and nose when sanding.

# Chapter 6

## Floors and Ceilings: Beneath Your Feet and (Not Really) Over Your Head

### In This Chapter

- ◆ Making small repairs to hardwood floors, and replacing a laminate floorboard
- ◆ Replacing a vinyl or ceramic tile or a small area of resilient flooring that's been damaged
- ◆ Cleaning stains and replacing a section of wall-to-wall carpet
- ◆ Smoothing a ceiling that's starting to show its age

There's a trend today for people to take care of their floors by adopting the Japanese custom of leaving their shoes at the door. It's a nice idea if your family can live with it; it will certainly cut down on the sweeping/vacuuming schedule. Of course, if you have pets who track in all kinds of debris, and you're not compulsive about making your guests and your UPS delivery man remove their shoes, your floors will sooner or later suffer the same indignities as any shoe-wearing household.

When really bad things happen to floors—deep gouges, extensive water damage, I’m talking disaster here—you’ll have to opt for refinishing or replacement. But barring a crisis, there are lots of things you can do to maintain an old floor’s—or its covering’s—attractive appearance. Read on.

## Wood Floors: Skin Repair

Water marks, burn marks, and scratches all affect the appearance of your hardwood floors. They’re like blemishes; some people don’t mind them, but others rush for a cover-up. If you choose the cover-up strategy, it’s best to deal with them as soon after they happen as possible. When you’re trying to fix a minor flaw, you’ll need to use a wax stripper to remove the protective finish from the damage site. Check with your hardware store associate about the appropriate stripping product for the finish on your floor. When you’re finished with the repair, you can rewax or oil the area.



### Ounce of Prevention

The liquids used for oiling, waxing, and repairing blemished floors may be flammable and toxic. Read the directions on the product container, and use and store these substances according to manufacturer’s instructions. When you’re working and the stuff is wet or drying, close off your work area from children and pets. Be sure to wear snug-fitting rubber or latex gloves to protect your hands from these liquids.

## Water Marks

I know everyone in your house is supposed to use a coaster under their drinks, but if Dad set a glass of water on the floor and forgot it, try this fix.

You’ll need the following:

- Fine steel wool (#0000)
- Paste wax or liquid floor wax
- Wax stripper
- Clean soft rags (or *cheesecloth*, cut into little pads)
- Odorless mineral spirits

1. Open the windows when you're using waxes and other floor repair products. Some people like the smell, but it's really not good to expose yourself to these fumes in an unventilated area. Wear gloves when you're using the liquids.
2. Using a wax stripper, remove the finish from the stained area.
3. Rub the water marks with the steel wool and a little paste or liquid wax.
4. If the marks don't disappear, wipe up the wax with a clean rag or cheesecloth pad. Rub the area again with the steel wool, using a small amount of mineral spirits.

## def•i•ni•tion

**Cheesecloth** is a light, gauzy fabric originally used to strain and hold cheese. In the absence of a good supply of soft, clean rags, and folded into palm-sized pads, it's a great substitute if you've run out of old flannel shirts and pajamas. Hardware stores and home centers sell it in inexpensive and generous packages.

Wipe clean, let dry, and rewax or reoil the area.

## Burn Marks

Grandpa's lit cigar fell on the floor and left a mark in the finish. Now you've got a good excuse to make him take his habit outside! But you still need to repair the floor. You'll need the following:

- Fine sandpaper (220–400 grit)
- Clean, damp rag
- Utility knife
- Putty stick or stick shellac to match the floor surface

If a burn has just darkened the surface of the wood, you can sand it with fine sandpaper, and wipe up the sanding dust with the damp cloth. (Wear a dust mask when sanding to protect your lungs from particles.) Finish as desired; you may want to give the area a light coat with the putty or shellac stick before you reoil or rewax the spot. Use the sticks according to manufacturer's directions.

For a deeper burn, follow these steps:

1. Carefully scrape out the burned area with the tip of your utility knife; be sure the blade is sharp (if in doubt, pop in a new one first).

2. Apply one or more coats of the putty stick or stick shellac.

Rewax or reoil the spot.



### What Pros Know

Putty sticks, stick shellac, and small containers of wood putty are sold in different colors to match different wood finishes. Without a spare piece of wood to make a perfect match, use your digital camera to take a photo of your floor and bring your snapshot to the hardware store. When in doubt about the color, go lighter rather than darker. You can always cover the lighter filler with a darker shade, but too-dark material will create another blemish.

## Scratches and Gouges

You don't have to be too compulsive about this; if you've got dogs and kids, you'll be fixing scratches every other day. But before routine waxing or oiling of your floor, and after stripping the protective finish, you can spend a little time touching up the scratches with your handy putty stick or stick shellac, then rewax or reoil the area.

For a deeper gouge, you may get a better result by using wood putty from a can to fill the gouged spot. When it dries, you can feather the edges with fine sandpaper. If the patch is too visible, touch it up with the putty stick or stick shellac. Then rewax or reoil the spot.

## Preventing Blemishes

If you dislike housecleaning as much as I do, you won't like this advice. But it works. I've already discussed the no-shoes strategy. But if you can't deal with that, the best defense for your floor's finish is frequent sweeping or vacuuming. Surface dirt is the real culprit in floor wear.

## Floorboard Fixes

Wobbly wood floors are annoying and dangerous: that thing that goes bump in the night could be you! Here are a few common problems, and how to solve them.

## Drilling Pilot Holes

Before you drive a screw or nail into hardwood floors, you must first excavate one or more of what's called a *pilot hole* with your electric drill. The drill hole acts like a "pilot" for your nail or screw, literally directing it toward a tight, clean insertion. Pilot holes are your insurance that you won't chew up the flooring with a poorly hammered nail or a screwy screw. Many instructions in this book call for pilot holes. If you're unfamiliar with using the drill, practice on a piece of wood that you clamp firmly to a work table (careful, don't drill the table). Wear safety goggles when you drill. Drill holes until you get a feel for the tool. (If you're having trouble, refer to the drill's use and care manual for further guidance.)

## Split or Cracked Boards

You'd be amazed at what falls in the cracks! One Christmas, my husband gave me a beautiful pair of earrings, and I lost one. It was tiny, and I'd given up ever finding it again. But when I repaired a crack in a dining room floorboard, what do you think I found?

You'll need the following:

- Electric drill
- A combination pilot bit (its shank should be slightly shorter than the depth you drive your nail)
- Annular ring nails, long enough to go through the floorboard and almost through the subfloor when countersunk (your nails can be about 2" for standard  $\frac{3}{4}$ " floor and subfloor)
- Claw hammer
- Nail set
- Wood putty or wood filler
- Finish to match your floor

*A combination bit, or screw pilot, is the right bit for drilling a pilot hole and countersinking the fastener. The bit is graduated to a larger diameter at the top, allowing the fastener head to be countersunk with a nail set (if it's a nail) or a screwdriver (if it's a screw). If you're not sure of bit length, check with your hardware store salesperson.*



1. Wearing safety goggles, drill pilot holes at an angle every few inches along both sides of the crack.

*Countersink pilot holes along a floorboard crack.*

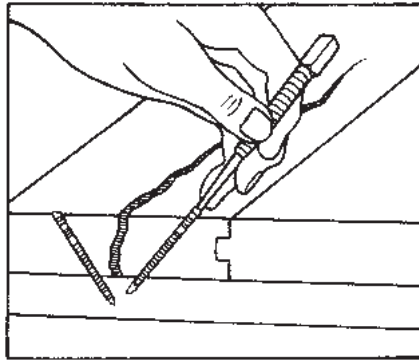

2. Drive in the annular ring nails, then countersink them using the nail set.
3. Wearing snug-fitting rubber or disposable latex gloves if you don't like putty on your hands, fill the nail holes and the crack with wood putty; let it dry.



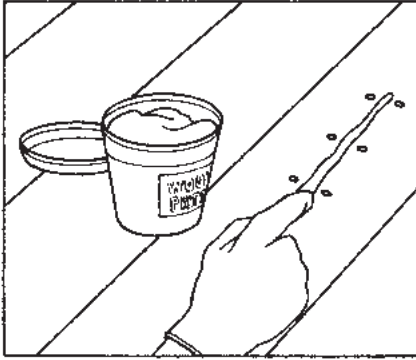

*Fill crack and nail holes with putty.*

4. If a better match is needed, apply a color putty stick or stick shellac, or finish to match the surrounding floor. Let it dry, then wax or oil as needed.

## **More Bit Bits**

This and upcoming chapters call for the electric drill and various bits. I don't know about you, but I have trouble sometimes judging whether a bit is "slightly smaller" than my fastener. I'm at that stage of life where I need reading glasses for all close-up work. If you also have trouble when comparing bits and fasteners, keep a drill gauge in your pocket or purse when you buy fasteners and corresponding bits in the hardware store or home center.

Your fastener should fit through the *next size larger* hole in the gauge than the correct hole for your drill bit. (The following illustration is a sample of what a gauge looks like; real gauges have the fractional sizes of each hole marked.) The fastener should be larger than the pilot hole, because you want the fastener to grab the wood (or other material) that surrounds the pilot hole. You want that fastener to fit tightly. With a drill gauge there's no more guessing.

Fractional drill gauge.

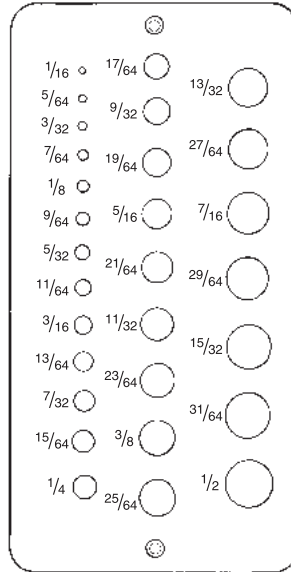

## Warped Boards

You may notice warping boards in the winter, when your heating system starts to dry things out, and wood fiber starts to shrink as it loses its natural moisture. If this is a persistent problem in your house, you may want to put more moisture into the air by using humidifiers in winter months.

This is a fix for a *badly* warped board; it doesn't yet look like Mount Everest, but creates a slight rise that looks weird and presents a possible tripping hazard.

You'll need the following:

- Electric drill
- Combination bit sized for your screws
- Standard screwdriver
- Slotted wood screws (1<sup>1</sup>/<sub>4</sub>" ; you'll be driving them straight)
- Wood putty
- Finish to match the floor

1. Wearing safety goggles, drill pilot holes every few inches at the high point of the warp along the length of the warped board.
2. Insert and then tighten the screws in each hole. Take care not to tighten so hard that you deform the screw head. Be firm but gentle.

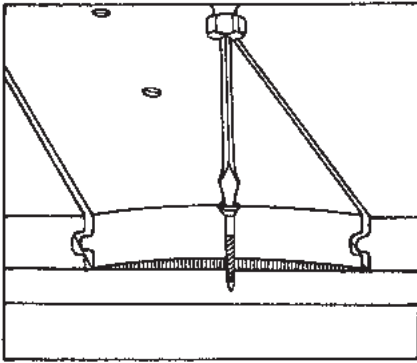

*Drive screws into the warp.*

3. Wearing snug-fitting rubber or disposable latex gloves if you don't like putty on your hands, cover the holes with wood putty and then apply finish to match the surrounding floor.

## Loose Boards

Loose boards are a fairly easy fix. If you can get to them from *underneath*, the solution is invisible, but this is only possible if you've got an unfinished ceiling below the floor, as in a basement or garage.

If you are so blessed, you'll need the following:

- Stepladder
- Electric drill
- Corresponding bit for your screws (no need to countersink these, aesthetics are not an issue)
- Screwdriver (standard or Phillips, depending on the screw heads)
- Measuring tape (for marking the drill bit, and locating the loose boards)

- ❑ Wood screws (1<sup>1</sup>/<sub>4</sub>" for standard 3<sup>3</sup>/<sub>4</sub>" floor and subfloor; the screws should be 1<sup>1</sup>/<sub>4</sub>" shorter than the thickness of the two layers)
  - ❑ Masking or painter's tape
1. The worst part of the job is locating precisely where on the ceiling the loose floorboard above is located. You can have a friend jump on the loose board, watch the movement in the subfloor and locate it that way, or you can do a measuring job to find it. (If walls above and below match up, it's easier.)
  2. Once you've located the spot, put on safety goggles to protect your eyes, and drill several pilot holes straight up from below, then insert and tighten your wood screws. It will help if your friend stands on the loose board, putting some downward pressure on the board as you tighten each screw. Your friend can also make sure that the screw does not break through the surface of the hardwood floor.



#### What Pros Know

When you're drilling holes from below the floor, you don't want screw points coming up through the floorboards. You can buy drill bits with stops that you can adjust to the desired drilling depth, or wrap a piece of painter's or masking tape at the correct point on the bit so you don't drill past it. Use either strategy whenever you want your drill holes to be a specific length.

*Fix loose board from below.*

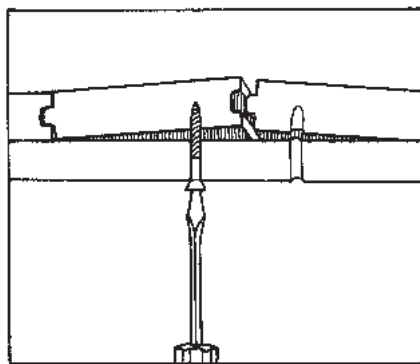

After all the effort it took to find the right board, the good news is, you don't have to cover the screws on the unfinished ceiling with wood putty. Phew!

To fix the loose board from above, you'll need the following:

- Electric drill
- Combination bit sized for nail diameter and countersink
- Claw hammer
- Nail set
- Annular ring nails
- Wood putty
- Finish to match the floor

1. Wearing safety goggles, drill pilot holes as shown in the following illustration, angled in from the board edge, through the board and into the subfloor.

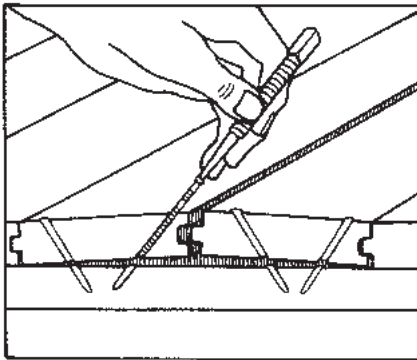

*Nail loose boards from above.*

2. Drive in nails with a hammer and countersink them with a nail set.
3. Wearing snug-fitting rubber or disposable latex gloves if you don't like putty on your hands, fill the nail holes with wood putty, and apply finish to match the surrounding floor.

## Stopping Squeaks

Squeaks are caused by pieces of flooring rubbing together. When my children were teenagers, I never bothered to fix the squeaks in the floor. In fact, I liked them. The more they squeaked, the easier it was to detect the patter of adolescent feet, sneaking in past curfew.

Here are two ways to try to silence a squeaky floor. For the first strategy, you'll need the following:

- A block of wood (a foot-long piece of 2×4 framing lumber is good; your local lumber yard may have some scrap if you don't)
  - A piece of felt, scrap carpet, or other thick fabric to cover the block
  - Claw hammer
  - A few common or box nails
1. Cover the faces (not the ends) of the block of wood with your heavy fabric or carpet and nail the material snugly in place on one long end of the block, leaving you three cushioned sides to work with.
  2. Starting in the center of the room and moving around and outward in a path toward the edges of the room, position the long, unnailed face of the fabric-covered block flat on the floor, and perpendicular to the floorboards, and tap it sharply with the hammer. Doing this may help ease the floorboards, which may have dried and shifted, back into place, so they don't rub together so noticeably.

For the second strategy you'll need the following:

- Glazier's points (the little metal pieces used to position glass in a window frame)
- Graphite
- Claw hammer
- Putty knife (2")

Coat the glazier's points in graphite, and then hammer them between offending floorboards. To do this, tap the hammer on the edge of the blade of the putty knife, using the opposite edge of the putty knife to push the points between the boards. Make sure the points don't protrude from the spaces so that they stick out above the boards (ouch!). The graphite-coated points act as space holders to keep the boards away from each other.

## **Getting at Squeaks from Down Under**

If the offending floor is in a room above an unfinished basement or garage, you can try to stop squeaks with yet a third strategy.

You'll need the following:

- Stepladder
- Claw hammer
- Wood shims

Again, you'll need a friend to walk around upstairs to locate the squeaky parts of the floor. Wherever the floor is squeaking, tap a shim into the space between the *joist* and the subfloor. Be sure to wear safety goggles to protect your eyes from falling debris.

## def•i•ni•tion

A **joist** is the framing that supports a floor or ceiling.

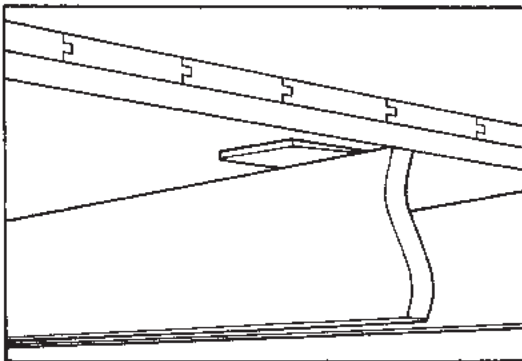

*Silence a squeak from down under.*

## Resilient Floor Fixes

Vinyl flooring in sheets and tiles is everywhere; it holds up to a lot of hard wear, which is probably why it's known as *resilient*. Cork and asphalt tile are also known as resilient flooring, but vinyl dominates.

The routine for maintaining a resilient floor is fairly simple: regular sweeping, vacuuming, damp-mopping, and occasional waxing to renew the surface when its factory-applied wear layer starts to wear thin. But sometimes, bad stuff happens to perfectly good floors.

At our house we had a bad habit of bringing home the pizza and putting it in the oven on a low setting to warm it up, still in its box. One day, my son was home alone and

tried to warm up the pizza I'd left on the counter. It was still in the box; I don't know the oven temperature he set.

The box caught fire, my son threw it on the vinyl floor and doused it with water and baking soda. No one was hurt, and the only damage was a nice, 2" square burn mark in the middle of the kitchen floor. You can be sure that no one in my house ever put a pizza box in the oven again! My heart still beats fast when I think of the dumb example I set for my children.

We were years away from renovating the kitchen, but fortunately I had some leftover tile. Here's how I made the repair.

## Replacing a Vinyl Tile

You must have a replacement tile for this one. Bring your replacement tile to the floor or hardware store and get the right adhesive and solvent.

You'll also need the following:

- Kitchen towel
- Steam iron
- Putty knife
- Notched trowel
- Adhesive for the tile
- Appropriate solvent to clean excess adhesive
- Clean rag to apply the solvent

*A notched trowel is used to apply adhesive for all kinds of tile and other flooring materials. Its notches leave a swirled pattern.*

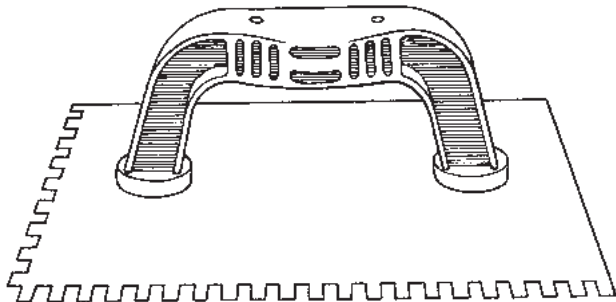



1. To soften the tile, place a towel over the damaged piece and iron it on a medium setting until the tile (and underlying adhesive) is very warm and begins to soften.
2. Remove the damaged tile by prying it up at one corner with the putty knife; gradually and carefully pull it up and off. (If you need to soften it more, lay it back down and apply more heat with the iron over the towel.)

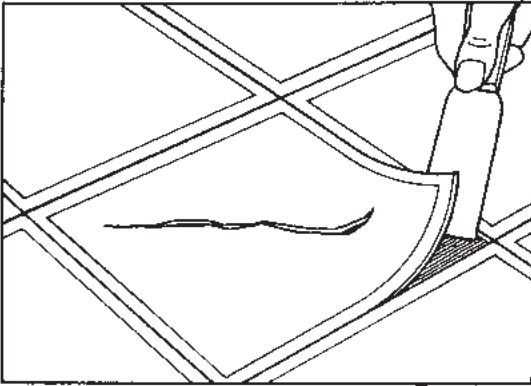

*Remove the damaged tile.*

3. Let the adhesive cool and harden, then scrape up the dry adhesive with the putty knife until the subfloor is smooth, clean, and flat.
4. Using the notched trowel, apply the adhesive to the clean, dry, flat subfloor. If any adhesive settles on the adjacent tiles, clean them up with the solvent, according to the directions.

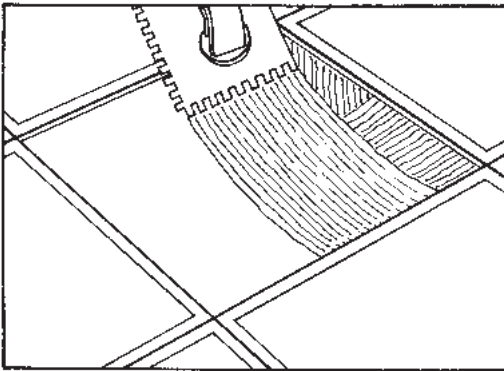

*Apply adhesive for tile replacement.*

5. Position the replacement tile above the adhesive-covered opening; make sure you've got the pattern, if there is one, going in the right direction.
6. Set two adjacent edges of the new tile against two adjacent tiles surrounding the repair; again, make sure the pattern matches. Press the tile into place.

If any adhesive comes up between the new tile and the adjacent ones, clean it with the solvent according to directions. Set the new tile level with the surrounding pieces; if it's too low, pull it up and add more adhesive.

If it's too high, press it down hard, and clean up any excess adhesive that squishes up at the edges with the solvent. Don't walk on the floor until the repair dries completely (check drying time on the adhesive container).

## Patching Sheet Flooring

If you look at the illustrations for patching a hole in wallpaper in Chapter 5, this repair is done in a similar way, just with a different material. Again, you'll need a left-over piece of flooring, enough to cover the damage and match the pattern.

You'll also need the following:

- Utility knife
- Straightedge
- Painter's or masking tape

Many floor patterns have imprinted seams in the shapes of blocks, bricks, or other geometric forms. Try to make your patch so the edges fall within the pattern's seams; it will be less noticeable.

1. Cut a piece of the leftover flooring with a utility knife and a straightedge. Work on a protected surface so that the utility knife doesn't damage bare wood (or the good portion of your floor!).
2. Position the replacement piece over the damaged area and match up the pattern. Secure this piece to the surrounding floor with painter's or masking tape. Cut a patch large enough to cover the damaged area by using the straightedge and utility knife to cut through both the replacement flooring and the old flooring, around the damaged area. Set aside the replacement patch you've just cut. Now you're ready to remove the damaged piece of flooring.

Removal and replacement are exactly the same as the fix for replacing a tile. Use the same tools and materials, and follow Steps 1–6 for “Replacing a Vinyl Tile,” described earlier. You’ll be substituting your patch for the replacement tile, but the procedure is the same.

## Ceramic Tile Floor Repairs

If you drop a pot or a tool and break a tile, or if the grout is chipping away, you can handle replacement and grout repair by following the instructions for wall tile repairs in Chapter 5. It will actually be a bit easier working on the floor instead of the wall!

To keep your floor grout in shape, you should treat it every year or two with sealant. This will make it easier to clean; it also keeps out the water you use when mopping—repeated soaking will degrade unsealed grout.

## Carpet Capers

Wall-to-wall carpeting feels great under your feet on a cold morning. And manufacturers have worked hard to perfect carpet technology so that this stuff is more stain resistant than ever. When you have new carpet installed, be sure to ask the dealer or installer to provide manufacturer’s specifications for cleaning the type of fiber your carpet is made of (file it in your home workbook!); knowing this info will help you when someone drops something nasty on it down the road.

## Taking Up a Wall-to-Wall Carpet

Sometimes you just have to get beneath your carpeting—a squeaky floor, perhaps, or a run of pipe that’s in a crawl space the plumber can’t get to from below.

Wall-to-wall carpet is usually attached around the perimeter of your room by means of narrow *furring strips* that are nailed to the subfloor along the walls. These furring strips are treacherous! The carpet sticks to them by means of dozens of protruding carpet tacks. So lifting the carpet for any reason can hurt you if you’re not prepared.

### def•i•ni•tion

In construction, **furring strips** are thin, narrow pieces of wood used to provide backing to support a finished surface. In the case of carpeting, the strips are prenailed with carpet tacks, making a base to hold down the edges of the carpet. The carpet padding is cut to fit within the perimeter of the strips, then the carpet is laid on top. It’s all very neat.

You'll need the following:

- Pry bar
- Wood shims
- Rubber mallet

You'll also need to move any furniture that obstructs the area you're trying to get at. Ease the heavy lifting by asking a friend or family member to help you with the moving. Four hands are also better than two when you're trying to move carpet. Its backing material—the stiff burlappy stuff that holds the fiber—is tough and sometimes heavy.

The process is simple.

1. Wearing a pair of heavy, good-fitting safety gloves, start in a corner of the room that's nearest to the spot on the floor you want to reach, and use the pry bar to loosen the edge of the carpet from the tacks, then pull the carpet up at its edge. If you've got base molding around the perimeter of the room, you can place a shim behind the heel of the pry bar to protect the molding from getting blemished or nicked as you pry up the carpet. Peel back as much carpet as you must to get to the problem; you'll probably have to weight the carpet ends with a pile of books or piece of furniture to keep them from snapping back at you.
2. Once you've got the carpet pulled back, you'll also have to deal with the padding, usually nice, light, springy foam stuff that's not too hard to handle. Fold this back too, and do your repair.

Be aware of the tacky furring strips. You don't want to put a bare hand down on them; the tacks can also snag your clothes.

3. When you finish your repair, first replace the padding; make sure it's nice and flat before you pull the carpet down.
4. Press the carpet in place along the furring strips, using a rubber mallet to hammer the carpet (gently) back in place on the tacks.

## **Dealing with Spots and Spills**

Many years ago, I was invited to a cocktail party at the home of a very famous writer and his equally illustrious wife. They lived in a beautiful brownstone townhouse in Manhattan. It had just been decorated: white rug, white upholstery—it was a

blizzard in there! I made the mistake of taking a glass of red wine, and of course someone bumped me from behind. The full glass of red wine began to seep ominously into the pristine carpet. I was horrified, and sure that replacing the rug would take all of my salary for a year or two.

Fortunately, the hostess was as smart as she was famous, and also most gracious to a young, clumsy woman (me). She quickly retrieved a towel and a bottle of club soda from the kitchen and blotted up the red wine. The blotting, the towel, and the club soda did the job perfectly. Her rug was saved, as was my equilibrium.

In addition to keeping plenty of clean towels and club soda on hand for clumsy guests at cocktail parties, here are the ABCs of spot and spill cleaning:

- ◆ **Act quickly.** The sooner you can take action to remove a substance from the carpet, the more likely you'll be to prevent a permanent stain.
- ◆ **Blot, don't rub.** Rubbing at the spill only sticks the mess more securely to the carpet fibers.
- ◆ **Continue.** You may have to repeat the process more than once. Persistence usually pays off.

You should keep a bottle of carpet spot remover with your cleaning supplies just in case of spills. Read the label, as not all removers work for every type of spot.

There are hundreds of substances that can leave their mark; refer to Appendix B for some good websites with further information on treating different kinds of stains.

Here are a couple of general guidelines:

- ◆ When you start trying to remove a spot, whether liquid, gooey, or solid, work from the outside toward the center of the spill, so you don't spread the mess around.
- ◆ Pudding, peanut butter, melted chocolate, and other gooey, semi-solid spills can be gently scraped up and lifted with a spoon or table knife. Remove as much of the stuff as you can with this technique, then use your spot remover and blot with paper towels. Don't rub. Repeat until you've done your best. When you're finished, rinse the area with water and



#### **Ounce of Prevention**

When you buy a bottle of spot remover, don't wait for the first spill to see if it's compatible with your rugs. Apply some (follow the package directions) to an inconspicuous corner of the carpet, and blot it up with a paper towel. If you see the carpet color on the paper towel, the remover and your rug are not compatible. Try another brand.

blot with paper towels. You can leave some dry towels on the spot and weight them down to soak up the water. When the towels have done their job, let the area dry some more.

- ◆ With ground-in dry solids, break them up with a fork or table knife and vacuum. Use the spot remover, followed by the blotting technique, for whatever residue remains.

## When Spot Makes a Spot

Pet urine can really mess up a carpet. I won't get into the psychology of why cats and dogs suddenly lose their manners. That's a subject for another book, but here's what you can do to take care of this business, pronto.

For stains that are still wet, follow these steps. You'll need the following:

- Paper towels
  - Newspaper
  - Bucket of cool water
1. Place a thick layer of paper towels on the wet spot; on top of this put a nice thick layer of newspaper. Weight the area with some heavy books, or stand on top of the newspaper/towel layers for a couple of minutes, then remove the dampened paper, and repeat the process.
  2. Rinse the area with cool water (warm or hot water will set the stain). Remove the water by blotting it up with paper towels. Let the area dry and, if an odor remains, use the product recommended below.

For stains that have already dried, try this:

Go to a pet store and find an odor neutralizing product and follow the instructions. These special solutions contain enzymes that work on the odor caused by urine. My friends and I, pet owners all, swear by a liquid neutralizer called Nature's Miracle, but there are other enzyme-based cleaners that also do the trick. The key is to follow the directions and repeat applications if needed. And repeat after me, *blot* the spots, don't rub them.

If Spot or Fluffy returns to the "spot," it means you haven't gotten rid of all the odor. Repeat the process, or go to the more radical solution, described next.

## Replacing a Stained or Damaged Section of Carpet

When all else fails, a badly discolored stain, a burn, or a tear in your wall-to-wall carpet can be cut out and replaced with a patch. This technique works on cut pile carpets; a patch is hard to hide on a looped pile rug. If you've got the latter, it's time to call in the professionals, or put a nice area rug over the bad spot.

This repair requires a piece of carpet that matches what you've got. Hopefully, you've saved your leftovers from the installation. If not, and you've carpeted a closet with the same material, cut a piece from a back corner or from under a piece of furniture. I'll never tell!

In addition, you'll need the following:

- Utility knife
- Straightedge
- Hot glue gun
- Carpet tractor

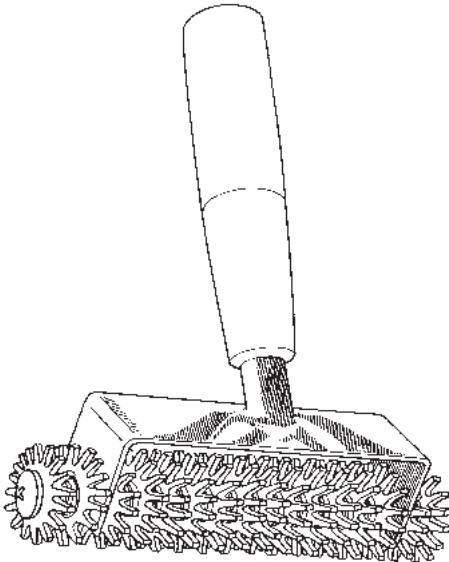

*If it were any larger than a hand tool, a carpet tractor would look like an instrument of torture. Rolling it over the seams between pieces of carpet hides the seams and blends the carpet fibers together. It's not cheap—about \$30—but it's a lot cheaper than a new carpet.*

*Crafters know all the wonderful ways a hot glue gun can pull things together. Available in corded or cordless (battery powered) models, these little beater/applicators use small sticks of glue that are beaten and then squeezed out of the nose of the gun.*

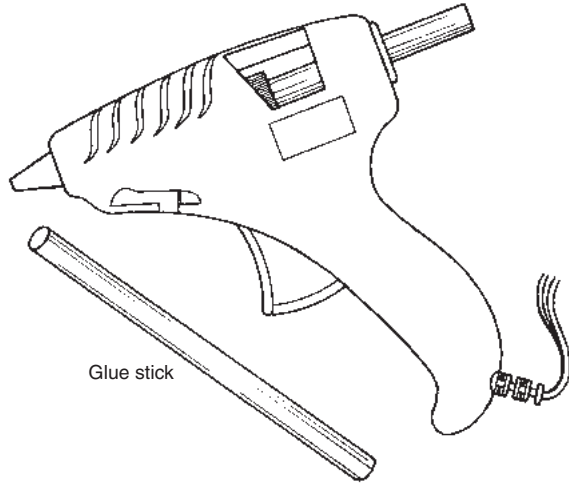

1. Use the utility knife to cut out a square around the stained area; guide the knife with your straightedge, and leave a border of 2"–3" around the damaged spot. Try to cut between the fibers so you only cut the backing, and take care not to cut the padding underneath.

*Cut out the damaged area of carpet. You'll use the damaged piece as a template for your patch.*

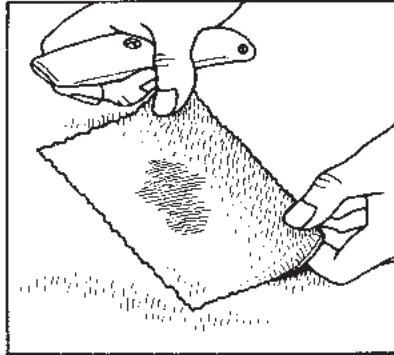

2. Use the damaged cutout as a template to cut the replacement patch from your leftover piece.



3. Apply glue to the edges of the patch, and set it into place. (Be careful of the gun's tip; it's hot when turned on. And keep the gun in an upright position when you're using it; laying it on its side can damage this little tool's thermostat.) As you set in the patch, work the glue into the edges of the carpet and the backing. Check the seams to see that they're well glued. If there are any gaps, carefully remove the patch, add glue, and reset.
4. Use the carpet tractor to roll the seams of the patch.

## First Aid for Floating Laminate Floors

With a finish that's tougher than hardwood, floating laminate floors are a homeowner's dream. It's really difficult to hurt them. Manufacturers sell repair kits to hide any surface flaws that develop.

If a strip gets punctured or badly scratched and needs to be replaced, here's how to proceed.

Fortunately, damage most often occurs in the hard-wear areas of a floor: at entryways and along high-traffic hallways. Because floating floors actually “float”—their tongue-and-groove, snap-together design is resting, but not nailed on an insulating underlayment—they can be removed without pulling nails or sawing them apart.

*If the damaged piece is close to a wall, the replacement is something like taking apart a jigsaw puzzle, then putting it back together. All you need to do is carefully and gently remove the baseboard molding and, starting with the piece closest to the walls, disengage the tongues from their interlocking grooves until you reach the piece that needs to be replaced.*

To do this repair, you'll need a replacement piece to match the damaged one. And to remove baseboard molding, you'll need the following:

- Pry bar
- Wood shims
- Hammer
- Nail set

1. Start from the corner of the room nearest the damaged board. Move all furnishings, rugs, and obstructions from the area to clear your working space.

2. The baseboard molding is generally nailed at its seams and where the molding passes over an underlying framing stud. First, wearing work gloves, pry the molding at these nailing points, then pry the molding carefully from the wall with your pry bar, putting a shim under the heel of the pry bar to protect the wall.
3. Starting closest to the wall and the corner, remove the floorboards one by one until you get to the damaged piece. Remove the damaged piece, and click in the new one. If it is an end piece and has been cut, you'll need to saw the new board to the same size. Measure carefully, and be sure you cut the right small end of the board—one end has a tongue, the other a groove; check before you cut!



### What Pros Know

If a board has been ruined, and it's in the middle of the floor, the repair is a time-consuming process. The board needs to be cut out, removed, and a new one fitted and glued, so the floor no longer "floats" in 100 percent of its area. This is a painstaking and tedious process. I suggest picking up the phone and calling your installer for this fix.

4. Click the rest of the floor back together and replace the molding. Use a shim between the hammer and the molding when you nail it back in.

If you've bent any nails, drive them through the backside of the molding, using the hammer and a nail set that matches the nail head. Drive in a new nail to replace the one you've removed. Countersink the nail; you can repair the nail holes with wood putty. When the putty dries, paint or use a wood-tone putty stick to match the baseboard.

## Ceiling Repairs

Most ceilings are composed of drywall; in older homes, they may be plaster. You can use the same techniques used to repair wall flaws that are described in Chapter 5, with one difference: you'll be working on a ladder. This means that you need to always wear goggles and some head protection (a cap or bandanna) to shield yourself from any debris that falls when you're working. Follow the rules for ladder safety in Chapter 2. Be sure your stepladder is tall enough for you to work comfortably; remember, the rule of thumb is that a ladder gives you its height, plus 4 feet, as its total comfortable upward reach.

Some ceilings are in terrible trouble. Plaster is chipping, and perhaps the cracks or holes you already repaired are not holding their own. There may be underlying structural damage, or a leak somewhere above the ceiling. Water stains are a clue that the damage extends beyond wear and tear; moisture is coming from a leaky roof or pipe.

Badly damaged ceilings take a lot of work and time, and you should call a pro if your ceiling's "time" has come.

## **The Least You Need to Know**

- ◆ Hardwood floors sometimes stain, spot, squeak, and warp, but you can fix a good portion of what ails them.
- ◆ Pilot holes are the best way to get a nail or screw into hard materials. If you're in doubt about which drill bit matches the fastener you're using, bring the fastener to the store and ask the hardware guy—or gal—to help you pick it out.
- ◆ You can soften up a vinyl tile with a steam iron and a towel to make it easier to remove.
- ◆ Removing stains from carpets requires quick action and no rubbing! Also, if at first you don't succeed, repeat the removal process. When all else fails, you can repair a small damaged area with a replacement patch.
- ◆ Repair of drywall and plaster ceilings is quite similar to fixing flaws in walls. Just use your ladder safely!



# Stairs: A Few Steps to a Happy Landing

## In This Chapter

- ◆ The anatomy of a staircase
- ◆ Silencing annoying, squeaky stairs
- ◆ Fixing a loose tread
- ◆ Securing handrails and balusters
- ◆ Making your stairways safe for elders and children

Fixing a staircase is usually a matter of tightening up its parts. Most stairs are constructed of wood, and wood is a responsive material: it expands when the surrounding humidity increases and shrinks when its environment is dry. Even though we can't see it happening, these tiny movements in the wood, coupled with human contact—you, your family, and your pets, walking, stomping, and bounding up and down, every day—loosen the parts of a staircase. Eventually, the stairs begin to talk, as only stairs can: they squeak.

If the joints of your staircase are not as snug as they once were, you can help them settle down.

Stairs can also be a hazard for the elderly and for small children. I'll talk about a couple of fixes to improve safety, too.

## Parts of a Staircase

It has more parts, but for our purposes, this is what you should know about staircases. Let's start with what we step on: the horizontal part of a step is called the *tread*; the vertical part is the *riser*. The *banister*—what we hold onto going up and down—has three main parts: the *handrail* that we grasp, the vertical posts spaced evenly along its length, which support the handrail, called *balusters*, and a larger, supporting vertical piece at the bottom of the handrail, called a *newel post*.

*Anatomy of a staircase.*

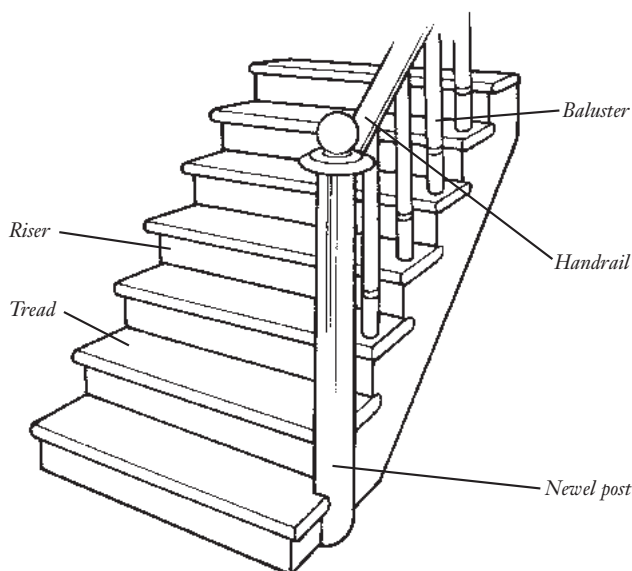

## Silencing Squeaks

Squeaky stairs signal loose joints, and they're fairly easy to fix. We'll start with the simplest procedure, and go from there.

### A Lube Job

This doesn't make it easier, but if you must, remove carpet and padding from the steps to get to the stair. (Find out how in Chapter 6.) Follow the directions and watch out for furring strips, which may be located not only at the top and bottom of the stair run, but also at an interval or intervals where seams of the carpet start and end.

To mark the offending steps, you'll need your roll of painter's or masking tape.

Ask the heaviest member of your family (no offense intended) to walk up and down the stairs so you can locate the protesting tread or treads. Mark them with a piece of tape.

You'll also need some powdered graphite, which comes in a little squeeze bottle. You can squeeze the graphite out of the container and into the offending, noisy *joints*. In the case where the joint is between the top of the riser and the tread, you might want to hold a piece of cardboard underneath the graphite bottle to catch the falling powder, then blow it off the cardboard into the joint.

This will lubricate the joints, and may be all you need. If not, try the next procedure.

### def•i•ni•tion

In carpentry, a **joint** is the intersection of two pieces of wood. There are many different kinds of wood joints.

## Repairing Squeaks from Below the Stairs

Like the wood floor fixes in Chapter 6, taming squeaks is much easier if you can get to them from under the stairs.

You'll need the following:

- Hammer
- Wood shims
- Carpenter's glue (yellow)
- A small block of wood for driving the shims

1. Put on safety goggles to protect your eyes from falling debris. Since you've already marked the offending stair(s), have your friend stomp on the squeaky treads, so you can see what moves.
2. Coat the wood shims with glue, and tap them, thin end forward, into the joint between the offending tread and its riser. Drive the shims in by placing the wood block between the butt end of the shim and the hammer head.



### What Pros Know

Basements can be dark, and sometimes it's hard to position a flashlight and work simultaneously. If your work area is poorly illuminated, buy yourself a work light. It's essentially a light bulb in a socket, surrounded by a little plastic cage, with a long cord, that you can hook or hang where you're working. Just always be aware of the cord so you don't trip yourself.

*Silence a squeaky stair with wood shims.*

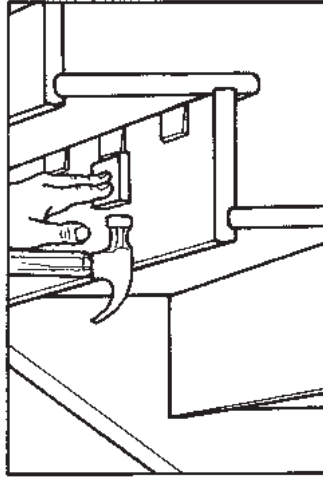

## Fixing the Squeak or Loose Tread from Above

You can tighten the joint between tread and riser by drilling straight down through the tread into the riser, and inserting and tightening the screw.

Be sure to mark the location for your drill bit carefully, and keep your drill bit straight—that is, perpendicular to the surface you are drilling. You don't want the screw to go through the tread and miss the riser!

You'll need the following:

- Measuring tape
- Pencil or awl
- Electric drill
- Combination bit sized for the screw you're using
- Screwdriver
- Flathead wood screws (2<sup>1</sup>/<sub>2</sub>" )
- Wood putty
- Sandpaper (220-grit)
- Finish or paint to match stair surface (not important if the stairs are covered)



1. Measure carefully if your stair tread is not flush with the riser; most treads extend at least  $1\frac{1}{2}$ " from their supporting risers. The edge of a standard riser where it meets the tread is  $\frac{3}{4}$ " thick, and ideally you want to drill into the center of the riser. Mark the spot with a pencil or awl.
2. Wearing safety goggles, drill two or three pilot holes; insert and tighten screws below the tread surface.

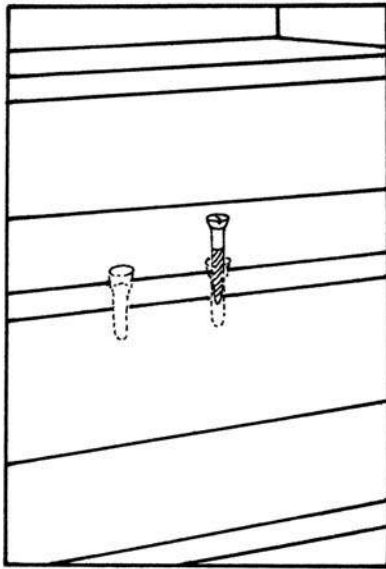

*Insert screws from above.*

3. Fill the holes with wood putty; wear gloves to protect your hands if you don't like to handle the putty. Let the putty dry, sand, and finish as desired.

Another way to fill the gap left by a countersunk fastener is to buy a package of small, round wooden plugs, the same size as the screw head. These are called *dowel plugs*, because these small wood wafers are cut from a wooden dowel. Coat one side of the plug with glue and insert the glued side in the hole; then finish as desired. Some people like to use these plugs; others prefer the putty fix.

## Getting a Grip on Handrails

With use, time, and fluctuations in humidity, the vertical balusters sometimes loosen in the *mortises* where they join the handrail, causing a shaky situation that's not good when you're negotiating stairs—the handrail should support *you*, not the reverse.

### def•i•ni•tion

A **mortise** is a hole or slot cut into wood or other material so that a projecting piece (called a **tenon**) can be precisely inserted. In woodworking, a mortise and tenon joint creates a good bond between two pieces of wood.

Here are two ways to tighten the relationship between handrail and baluster.

For the “shimy” solution, you’ll need the following:

- Wood shim
- Carpenter’s glue (yellow)
- Small wood block (to drive the shim)
- Hammer
- Utility knife

1. Coat the wood shim with glue.
2. Using the small block as a driver, hammer the shim into the joint between the baluster and the handrail. Don’t try to drive the two pieces apart, just drive the shim until it closes the gap between handrail and baluster.
3. Using the utility knife, trim the shim flush with the banister. Shims are pretty easy to cut; they’re softwood.

For the “screwy” solution, you’ll need the following:

- Electric drill
- Combination bit sized for the screw you’re using
- Screwdriver to match screw head
- Flathead wood screws
- Wood putty
- Sandpaper (220-grit)
- Finish to cover repair (wood finish or paint)

1. Wearing safety goggles, using the combination bit, drill a pilot hole up through the baluster into the handrail at a 45° angle.

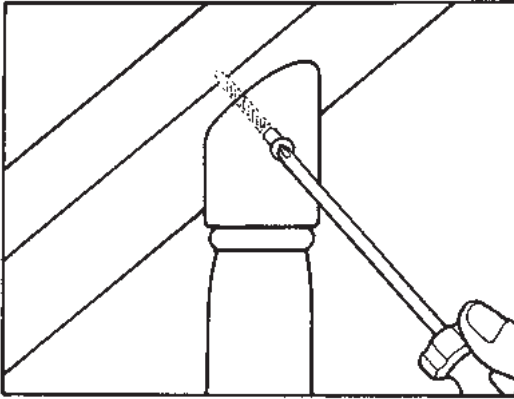

*Angle a screw through the baluster and handrail.*

2. Drive in, countersink, and tighten the screw.
3. Fill the hole with wood putty; let it dry. Sand the repair and finish as desired.

## **Off-Base Balusters**

Sometimes the baluster gets loose in its bottom mortise—its joint with the stair tread. You'll need another pilot hole and countersunk screw for this one.

You'll also need the following:

- Electric drill
- Combination bit sized for the screw you're using
- Screwdriver to match screw head
- Flathead wood screws
- Wood putty
- Sandpaper (220-grit)
- Finish to cover repair (wood finish or paint)

1. Wearing safety goggles, drill the pilot hole at an angle through the baluster and into the tread.

*Tighten a baluster with a screw support.*

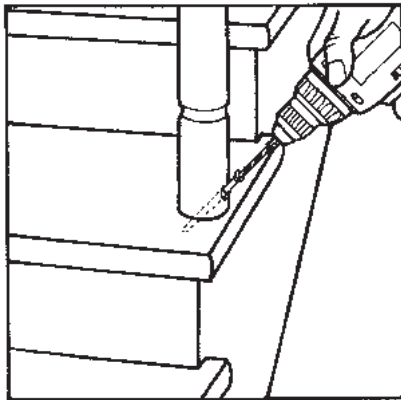

2. Drive in, countersink, and tighten the screw in the predrilled hole.
3. Fill the hole with wood putty; let it dry, then sand and finish.

## Safe Stairs

For elders and children, a staircase can be a hazard. A secure handrail and stair treads tight to the risers are great first steps, but the young and the frail may need extra help.



### Ounce of Prevention

Equip the electrical receptacles (outlets) in your stair halls with night lights. They use a miniscule amount of energy but make the way safe for anyone who's moving around when the house is dark. Keep a supply of the little bulbs with your other light bulbs, so you always have a spare when this little "night watchman" suffers a burnout.

## Elder Safety

Falls are the leading cause of life-threatening, debilitating injury for the elderly, and falls on stairs are a common culprit. If you have an older person living with you, you want to make sure that they can *see* the steps.

You'll need the following:

- Scissors
  - A roll of reflective tape (it glows in the dark, a plus at night and during power outages and other emergencies)
1. Make sure the stairs are clean and dry so the tape will adhere.
  2. Cut each strip of tape so that it will extend the entire length of the tread.
  3. Secure the reflective tape to the top, front edge of the tread. Make sure it is lying flat. Place the tape on the top front edge of the stair landing, and every stair in the staircase.

If there are any step-ups or places where the floor is uneven—sills in doorways, for example, where an elderly person might trip—mark these step-ups and sills with reflective tape as well. Even a half-inch rise in the floor surface could create a problem for someone with poor mobility or vision.

## **Kidproofing the Stairs**

Child safety gates have been around for years. They're an inexpensive way to keep active and curious youngsters from an accident on the stairs, or any other place where they might find themselves in harm's way.

When my son was just 10 months old, he was quite the little bruiser, built solid and full of energy. We had put safety gates on our stairs, but at that time, what was available was a fairly simple design that clamped to the sides of the stairway by means of pressure. There were no fasteners on the thing that I could screw into the wall.

One day, my boy was cruising around on the upper floor in his little walker, careening against the walls (why I learned to repair drywall). He worked up such a head of steam that, in a split second, he crashed against the pressure-installed gate and was on his way down the steps when I grabbed him, and the walker, preventing a disaster. Within an hour I was at the hardware store, looking for the right straps and screws to secure the gate to the walls. We rigged our own safety setup. And the walker went, as my son would say when he couldn't locate something, "bye-bye someplace."

Pressure mounted gates are still around, but the Consumer Product Safety Commission does not recommend their installation at the top of stairs, because children (like someone I know) can push them over and fall down the stairs. Select gates with hardware mounts, screw them into the wall securely, and periodically check the screws to see that they are still tightly fastened.

## **The Least You Need to Know**

- ◆ A staircase is made up of the tread, riser, handrail, balusters, and newel post.
- ◆ You can make invisible repairs to the stairs if you can get at them from underneath.
- ◆ Wood shims and countersunk screws tame squeaks and tighten wobbly parts.
- ◆ Add safety insurance to your stairs: night lights in the hall, reflective tape on the treads for your elders, and hardware-mounted safety gates for your tots.

# Chapter 8

## Getting Clear About Windows

### In This Chapter

- ◆ Parts of a window
- ◆ How double-hung windows work
- ◆ Smoothing the passage of sticky windows, and tightening up loose ones
- ◆ Dealing with the pain of broken panes
- ◆ Common screen repairs

Your home's windows are its (and your) eyes on the bigger world. In addition to lighting your interiors, keeping fresh air flowing in good weather, and shutting out the elements when it's foul outside, windows that work and look good make a statement about you. So subdue that stubborn sash, banish those broken windows and torn screens, and give your home a clean, bright face.

## What a Pane! Parts of a Window

There are many kinds of windows, but nothing's better for your *fenestration* vocabulary than learning the names of the parts of the most common window style—the double-hung. Now you can talk the talk!

### def•i•n•i•t•i•o•n

**Fenestration** is the term architects use for the design and placement of windows in a building.

Let's start from the top. The *header* is the top horizontal piece of the frame. The *jamb* refers to the vertical side pieces of the frame. The *sill* is the horizontal part at the bottom of the frame. (Looking at the window from outside, you'd see the stool where the sill is, often supported by a small board called an apron.)

Now let's get to the real business of this window. Double-hungs have two moving pieces, called the *sash*. The piece on top is the *upper sash*, which can be lowered from its closed position, and on the bottom is the *lower sash*, which can be raised. The rails are the horizontal part of the sash frame and the stiles are the vertical parts.

The sash, upper and lower, hold the glass portion of the window. A single piece of glass is called a *pane*. A sash can have one or more panes; the dividers between the panes are called *muntins*. On both vertical sides of the sash are *channels*, which guide the sash up or down in a straight line. The small molding piece that runs up the front, at the sides of the lower sash is called the inside *stop*, which keeps the sash running smoothly in its channel. The sashes lock together by means of a two-piece *latch*, positioned atop the upper rail of the lower sash, and the bottom rail of the upper sash.

If your windows look like double-hungs, but the upper sash doesn't move, these are called single-hung windows.

Are you getting clear about windows yet? Don't worry; review the illustration if you forget some of the names referred to in the repairs.



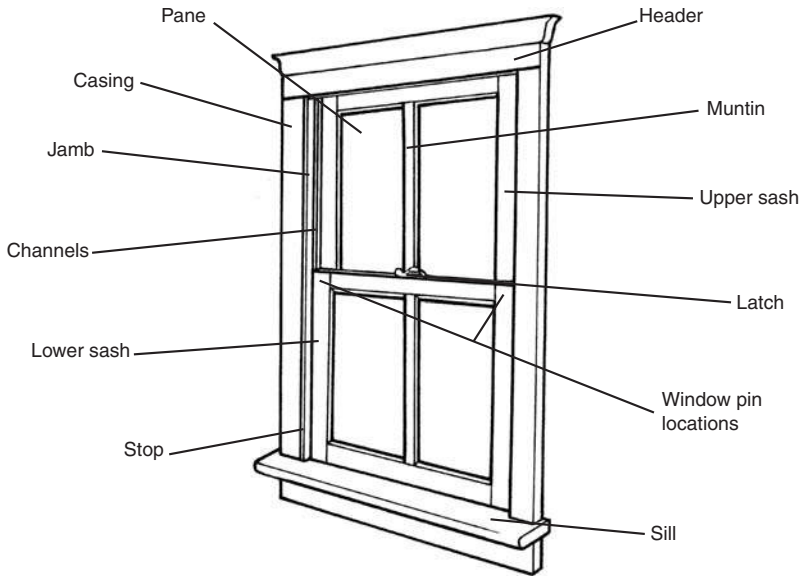

*Parts of a double-hung window, as it looks when viewed from inside.*

## How Double-Hung Windows Work

Modern double-hung windows are truly things of beauty. Double glazed, weather-stripped, and vinyl-clad at the factory, they need very little maintenance. In the spring and fall, you just clean the channels, and spray and wipe the moving parts with a little lubricant.

When it's time to wash the glass parts, the real benefits of modern double-hung windows are even more apparent. The sash of most good-quality double hung windows can be removed from their channels and washed. No more ladders, no more freezing fingers as you try to clean them from the outside. Technology can be a blessing.

However, this part of the chapter is not for owners of fabulous, new, easy-care windows. It's for the rest of us who have sticky, drafty, balky, and unrepentant old wood windows that need more than their fair share of attention. So let's get busy!

## Stubborn Stuck Sash

This section proceeds from a no-load solution to some nitty-gritty ideas.

### Wait and See

This is not often the case (it's too easy), but sometimes the only problems with your windows is that it's been hot and humid for days. If the windows worked well before the heat wave, you may want to leave them alone temporarily.

Once a dry spell arrives, your windows may go up and down as before.

Don't take drastic action to sand or plane windows during humid seasons. While they may be sticky in the spring and summer, the cooler, drier months could set your newly sanded windows rattling in the jambs because you removed too much wood. If you are trying to make balky windows glide to your tune in summer—when you need to open and close them frequently—try the less invasive fixes.

### Gentle Tap, Tap, Tapping

Before you disturb the paint on the windows with any type of prying tool, you can try this little wake-up call. This technique works best if you can work both sides of the window; you may need a helper if the windows are on the second floor and require a ladder to reach their exterior side.

You'll need the following:

- Small wood block
- Piece of heavy cloth
- Duct tape
- Claw hammer
- Sponge
- Lubricant or silicon spray

1. Make sure the sash is unlatched. Wrap the wood block in a piece of heavy cloth or felt to protect the finish on the windows. Keep the cloth in place on the block with some duct tape, if you like.

2. Place the block against the frame along the bottom rail of the lower sash and gently tap it with the hammer along the width of the sash. If your windows are on the first floor, go outside and do this to the same rail on its exterior side. Gradually work along the stiles of the sash, inside and out, working upward until you reach the top of the window.
3. If this frees the sash, move it up and down, and examine the channels. Clean out any debris and dirt with a damp sponge. Let dry, and spray some lubricant or silicon spray in the channels.



### What Pros Know

If your windows are stuck because they've been painted shut, use a utility knife to carefully score the paint that has bonded any window parts together: between stop and sash, between upper and lower sash, between sill and sash. You'll only do more damage to the paint if you skip this step before trying to move or pry the windows.

## Don't Want to Pry, But ...

If gentle tapping doesn't work, you'll need a stronger approach. You'll need the following:

- Putty knife
- Rubber mallet
- Pry bar
- Shim or thin block of wood

To pry the window from inside:

1. Make sure the sash is unlatched. Insert the blade of a putty knife into the crack between the stile of the lower sash and the stop, tapping it lightly with the rubber mallet to free the window. Do this along both stiles.

*Pry open a tight sash from the inside.*

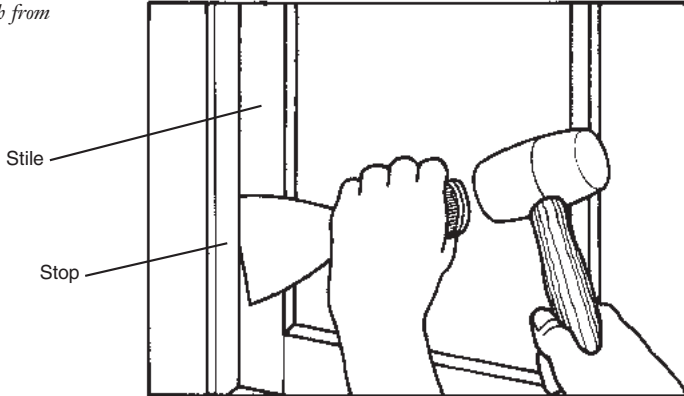

2. If this frees the sash, move it up and down. Work the putty knife into any spots that are still resistant.

Once the window is moving freely, examine the channels. Clean out any debris and dirt with a damp sponge. Let dry, and spray some lubricant or silicon spray in the channels.

To pry the window from outside:

1. Make sure the sash is unlatched. Using a thin wood block or shim to protect the stool from the pry bar, insert the pry bar into the crack between the stool and the sash. Work first at one end of the sash, then the other, so that the sash will move up evenly.

*Pry open a tight sash from the outside.*

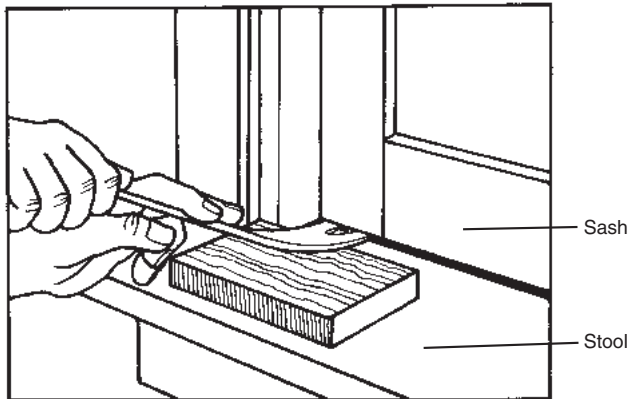

2. If this moves the window, go back inside and open it. Examine the channels, then clean and lubricate them.

## Windows That Won't Stay Open

You can prop up a window that won't stay open with a stick or a ruler, set in the channel below one side of the sash. Or you can install some hardware, as described next. But neither of these “make do” fixes really corrects the underlying problem.

A sash that's loose in the jamb, and won't stay put when it's opened, usually means that its raising/lowering mechanism has failed. In old, single-paned wood windows, this is often a rope-and-weight pulley system; your window won't stay open because the weights have come loose from the rope, or the rope has simply broken from age and wear. If you look at the top of the jamb, you'll probably see the little pulley.

Some rope-and-pulley controlled windows have access panels in the jambs that allow you to get to the weights without removing the window casings. Even when you can get to them, though, this is a delicate, often frustrating (the weights fall down inside the walls!), and time-consuming job. Remember, these old, single-paned windows are probably leaky, and they're costing you for the extra money you have to spend on heating and air-conditioning your drafty house. The best fix is to start saving for new, energy-efficient sashes that can be fitted in the old jambs, or spring for completely new windows.

In the meantime, you can apply weather stripping at the joints of your windows: between sash and sill, between the sash and the stops, anywhere air is leaking in (put your hand at one of the joints on a cold, windy day and you'll feel the cold air passing through).

And to keep the windows up when you do want fresh air, you can install little stainless steel controls in the channels of the lower sash that provide some resistance to your weight-less window. They work like the stick or the ruler, but they're a bit more sturdy, and only cost a couple of dollars.

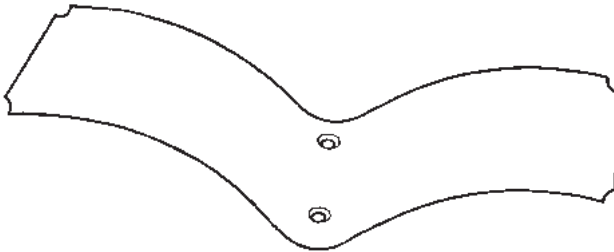

*Window control.*

To install them, you'll need the following:

- Ruler or dowel (to hold up the window while you work)
- One pair of window controls per loose window
- Claw hammer
- Box nails
- Measuring tape
- Pencil or awl

1. Raise the lower sash as far as it will go, and secure with the dowel or ruler; you may want to prop it on both sides for safety.
2. Position the control in the lower sash channel so that the nail holes (which have little burrs on the backside where they meet the channel) are about an inch below the highest opening you want for your window. Nail in one control.

*Window control in place.*

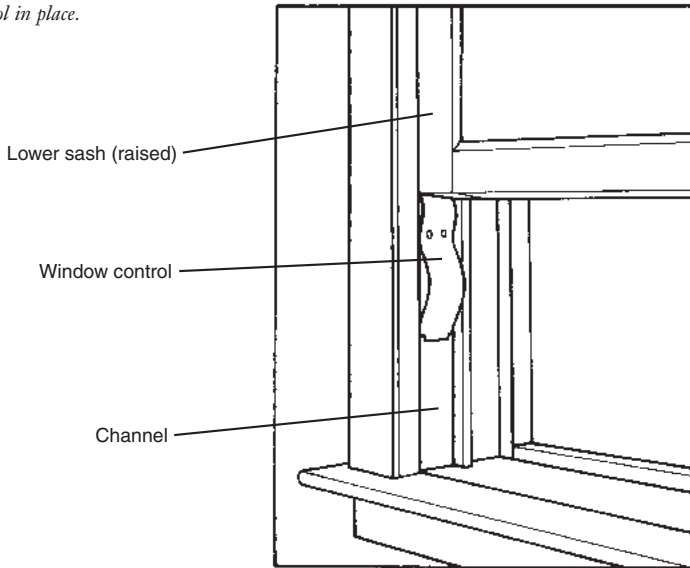

3. Nail in the control on the opposite side of the window. Measure and mark the location of the nail holes for the second control with the pencil or awl, so both controls are nailed at the same height in the channel.
4. Remove the supporting dowel or ruler and carefully lower the window so that the top sections of the controls are between the sash and channel as you lower the sash (see the previous illustration). The controls are flexible, so they act like springs to tighten the movement of the sash.

## When Windows Break

Modern windows—the double-glazed, gas-filled, or tempered variety—are pretty sturdy. But when they break, you'll need a professional glass installer to fix them. Current building codes require that door glass (for *sidelights* and other door panes) be tempered. If it breaks, it does so harmlessly into about a million little chips per pane. I know this because my lawn guys got too close to our French doors with a weed-whacker, and it was doomsday for the bottom right pane. Specialized glass products have a little seal imprinted in a lower corner of the glass, which is your indicator that all such panes need professional replacement.

When tempered or other specialty glass breaks, you'll have to do a temporary repair until the glass man arrives. Even when you're just picking up glass chips, take precautions when you clean up the glass.

You'll need the following:

- Newspaper
- Painter's, masking, or duct tape
- Putty knife
- Measuring tape
- Utility knife (to cut cardboard make-do)
- Sheet of corrugated (box) cardboard, or sheet of transparent acrylic plastic, cut to fit opening

### def•i•ni•tion

A **sidelight** is a window positioned next to a door. Usually doors with sidelights have one on either side of the door. Tempered glass has been heated and cooled repeatedly in a controlled environment to give it more strength than conventional, single-layer window glass.

To clean up a broken specialty glass window:

1. Sweep up and discard any chips of glass on either side of the window (interior and exterior). Tape a piece of newspaper on the inside of the opening so more glass does not fall inside. Wearing heavy gloves and safety goggles, and working from outside, use the putty knife to carefully knock off any remaining pieces of glass; put the debris in a supermarket paper bag (it's thick), and discard.
2. Measure the dimensions of the now-empty opening, and cut a cardboard template that you can put in place with duct tape or masking tape from the inside. (You can also take your measurements to a hardware store and get a piece of Plexiglas cut to fit, for a more aesthetic make-do.)



### Ounce of Prevention

Large panes of glass are too heavy to handle. If your panes are larger than a foot-and-a-half square, leave replacement to the pros. You must handle glass carefully, by its edges, or it will easily crack. Start small if you want to learn to work with glass!

For small window panes that are single-glazed (one layer of conventional glass, no little imprint in the lower corner), you can replace them yourself. I don't recommend cutting your own glass unless you've had a lot of experience with a glass cutter (it's best to test your skill with a small pane first). Do the cardboard make-do fix, and take your window frame measurements to the hardware store so they can cut your glass.

You'll need all the tools and materials mentioned earlier for removing tempered glass and installing a temporary make-do (cardboard will do until you get your replacement glass).

In addition, if you're doing the replacement, you'll need the following:

- Pliers
  - Sandpaper (100–150 grit)
  - Sheet of glass (see Step 6)
  - Glazing putty (sold in ropes so you don't have to roll your own)
  - Glazier's points
  - Touch-up paint (for repaired window frame)
1. Unlike tempered glass, shards of single sheets of glass are very sharp. Work from outside and, as with tempered glass, tape newspaper on the inside of the window.



2. Wearing heavy gloves and safety goggles, remove the large pieces of glass first. Use the putty knife to knock out remaining small bits of glass.

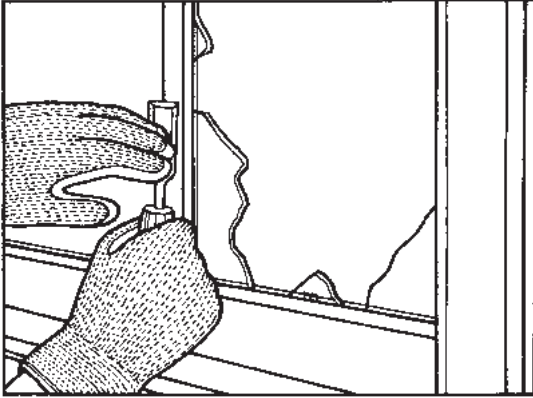

*Remove a broken single-glazed pane.*

3. Remove the old glazier's points with pliers.
4. Lightly sand the edges of the opening to get rid of any remaining putty.
5. Measure the window opening; measure and install the cardboard make-do.
6. Take your opening measurements (remember, measure twice, cut once) to the hardware store and get a piece of glass cut. Tell them that your measurements are the actual size of the opening; they'll cut the glass  $\frac{1}{8}$  of an inch less than the total width and length.

Once you have your replacement glass, you can proceed with the next part of the repair:

1. Remove the cardboard make-do. Working from outside, press a rope of glazing putty, about  $\frac{1}{4}$  inch thick, around all the edges of the window opening. This is your setup for installing the glass.
2. Carefully press the pane into place, then insert the glazier's points into the frame, pushing them in with the putty knife. Use two points on each side if it's a small pane. If the glass is longer than a foot in length or width, insert the glazier's points every four to six inches.

*Insert glazier's points into frame.*

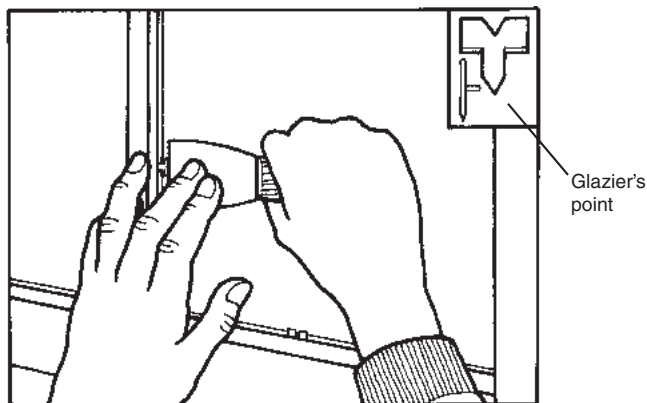

3. Apply another  $\frac{1}{4}$ -inch rope of putty around the edges of the opening. Use the putty knife to smooth the putty and form a good seal with the window frame.
4. When the putty is dry, you can paint it to match the surrounding wood.

## Screen Test

The screen and storm windows at our ancient house are heavy and cranky. They're in wood frames—no nice little slide-out or pop-out aluminum framed stuff. Our least favorite weekends in spring and fall are those when we have to change from storms to screens, and from screens to storms. But before we do any of the really tiresome leg work and ladder climbing, the stored windows must be cleaned. You clean storms the way you clean any window: with glass cleaner and clean rags or paper towels. And the spring changeover is the time to replace any storm window glass. If it's the single-glazed variety of storm window, you can follow the previous directions.

This is also a good time to clean the frames, if your storm/screens are of the slide-out variety. Clean the runners and the channels where they fit, and lubricate them with a lubricating oil or silicon spray—they'll go in and out more easily.

To clean dirty screens, simply spray the screens with your garden hose and clean them with the sponge (or a wire brush) and soapy water. Rinse, let dry, and hang 'em!

## Screen Repairs

Once the screens are out, you may notice some defects: a loose screen here, a little hole there. Last spring while cleaning her window screens, my sister noticed that her big red Persian cat, Gizmo, had been slipping out of the house the previous summer because one of the screens for the living room windows had come loose from its frame. She had to replace it, or Gizmo would be doing his warm-weather wandering once again!

Here's how to handle common screen defects.

### Small Holes

Holes in the screens let in all kinds of unappealing critters when your windows are open: mosquitoes, moths, flies, and other little creatures will take advantage.

To some of us, little repairs in a screen door might look a bit tacky, so if it bothers you to have a patch at your door, you might want to go all the way and replace the whole screen (see how in the next section; door screens work just like the window screens). But for window screens that don't get as much scrutiny as a front or back door, you can patch; it's a less time-consuming fix.

You'll need the following:

- Scissors
- Screen patch (these come in various sizes, available at most hardware stores; make sure the color/material is a close match to your screen—some are metal, some are fiberglass—or it really will show)
- Glue for fiberglass screen (ask the store salesperson for a good, waterproof variety)

You'll notice that screens are composed of lengths of fine, interwoven metal wire or fiberglass *filament*.

1. Cut a patch to fit over the hole in the screen; the patch should extend at least 1"–2" around the circumference of the hole.

### def•i•ni•tion

A **filament** is a slender strand of fiber or other material. The thin wire that is the light-producing element of a bulb when electric current passes through it and the element that emits electrons in a vacuum tube when current is passed through it are also known as filaments.

2. You'll want to remove a wire or filament (or two) from each side of your screen patch to give you a little bit of extra length to make the fix.
3. Position the patch over the hole on the interior side of the screen. Insert the wire ends of each side of the patch into the intact screen holes around the tear or hole you are covering. Bend the wire ends so they grip the intact screen. You may want to use needlenose pliers or even a nail file to help you bend the wires—they're tiny, and tough to work with if you have big hands. If the screen is the soft, fiberglass filament type, you won't bend the ends—they'll lie on top of the edges of the repair. You can glue the ends to the existing screen with the waterproof glue.

## Replacing Screens

If a screen has big holes or tears or has become loose and taken on a “wavy” look, you'll want to replace it. Even if the old screen isn't torn, if it's bulging in places it may be weakened by the stretching. You may as well get new material to work with. Use the old screen for patches (store it in one of your “leftovers” bins).

The most common window and door screens are attached to the screen's frame with a flexible, vinyl rope known as *spline*. The spline fits into a groove where mesh meets frame. If you look carefully at the corners of the screen, you may also see little plastic pieces that help fit the spline snugly in each corner.

### def•i•ni•tion

**Spline** is a piece of wood, metal, or plastic that is used as a connecting or framing piece between two sections of material. Spline can be used to hold a screen in its surrounding frame; the material that frames caning in a chair seat where it meets the wood or metal part of the seat is also known as spline.

If the screen is mounted in the window (or door), you'll need to detach it from the surrounding frame. In the case of window screens, you'll probably just need to pop or slide them out. A door screen may be mounted to the frame with screws; if so, unscrew the screen from the frame, take out the screen, and put the screws in the screw holes in the window or door with a couple of turns so they don't fall out. Loose screws are always rolling away and getting lost!

You'll need the following:

- Needlenose pliers
- Narrow putty knife or flat-tipped (standard) screwdriver

- Mesh screening
- Measuring tape
- Scissors
- Spline tool
- Utility knife
- Replacement spline
- Plastic corner pieces, if you have these in the corners

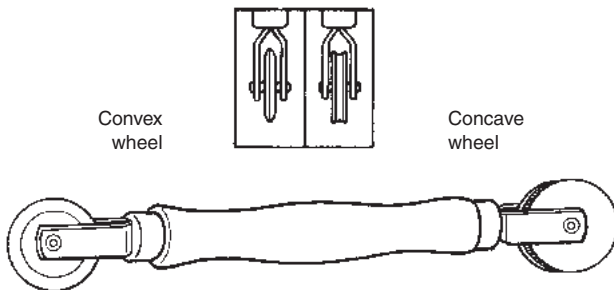

*A spline tool is a hand tool with a wheel at each end. One wheel has a convex (∪) rim, for pushing the screen into the spline channel; the other wheel has a concave (∩) rim, for pushing the spline down over the mesh and into the channel.*

While setting in the mesh and inserting the spline, an extra set of hands is helpful for holding the mesh in place. Or you can hold the mesh down at the corners you're not working on with a wood block or two.

You will need to bring samples of your mesh screening, old spline, and plastic corners (if they're used for your screens) to the hardware store so that you can buy the exact match of each material. There are different types of all three.

You will also need to measure the screen so that you buy replacement screening of sufficient size to cover the screen opening. Also, measure the perimeter of the window opening(s) so that you buy a sufficient length of spline.



#### What Pros Know

Remember geometry? If you do, skip this tip. If math gave you a rash, read on. It's not necessary to measure all four sides of a rectangular opening to find the distance around it. Perimeter = length + width times 2. Aha, applied mathematics! Your geometry teacher told you it would be useful, and the time has come!

1. Lay the screen flat on a sturdy work surface. Starting in one corner, remove the little plastic corners (if they're there) with the needlenose pliers, or pop them out with the screwdriver tip. Pry out the spline with the putty knife or screwdriver, going corner to corner. The spline may be dirty or gunky, so the edge of the knife or tip of the screwdriver can assist you in getting it out cleanly.

*Remove old spline.*

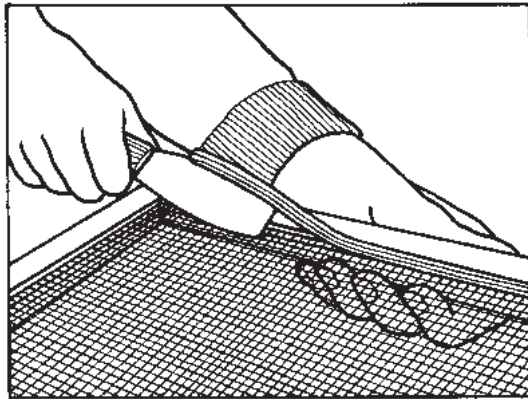

2. If you're saving the old screen, roll it up and set it aside. Otherwise discard it. Check the channels from which the old spline and screen have been removed. If they're clean, go to Step 3. If they're dirty, get a bucket of warm water, a sponge, and some paper towels, clean them and let them dry.
3. Lay the new mesh screen over the window (door) frame. Make sure the mesh is lying square to the frame; check at the edges to see that the gridwork of the mesh lines up with the frame so it doesn't look crooked.
4. Measure the frame's outer dimensions, and with the scissors, cut the mesh to this size. Cut a little square out of each corner of the cut piece, no wider than the frame. This will keep the mesh from bunching in the corners when you install it.
5. Starting in a corner, push the mesh into the spline channel with the convex (∪) wheel of the spline tool. Go all the way up and down one side. You're trying to create a light indentation, not scrunch down the mesh. The spline will do the holding.

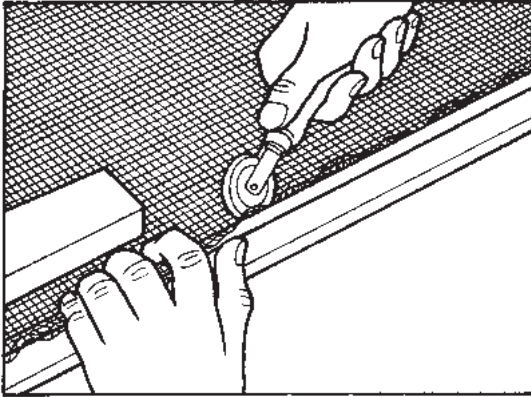

*Use spline tool (convex wheel) to insert mesh in channels.*

6. Starting in the same corner where you began Step 5, using the concave (∩) wheel of the tool, push the spline into the channel over the mesh. Put your other hand on the screen, or have your helper hold it, so that the tension on the screen is even and it doesn't bunch up. When you've fully inserted the spline on one side, follow Steps 5 and 6 to install the spline on the other three sides.
7. Once the spline is set around the perimeter, use the screwdriver to push the spline into all four corners; trim the end of the spline with the scissors. Trim any mesh that still overlaps the frame with the utility knife. If your original screening had plastic corners, install the new ones.

You're done! Put the screen back in the window or door opening.

## Installing Security Pins in Windows

In areas of your home that are hidden from view on the ground floor, it's easy for someone with bad intentions to break a window, undo the latch, and make mayhem. If you have a perimeter security system installed, that's one way to safeguard unwanted entry. Security gates (not window guards, which protect children from falling out) for windows will do the job, but will also make you feel like you're living in a prison. I had these in one apartment in Manhattan where my bedroom windows opened on a fire escape. I hated the feeling of being locked in, and moved out within months.

If you don't have the budget for a security service, you can add a layer of protection from forced window entry using the simple method of drilling holes through the

lower sash of your double hung windows and installing window security pins, common nails, or eye bolts that prevent the window from easily being raised, even if a pane is broken out.

You'll need the following:

- Measuring tape
- Awl or pencil
- Electric drill
- Window pins, eyebolts, or common nails; one pair for each window
- Drill bit slightly larger than pins, bolts, or nail you are using
- Masking or painter's tape, or bit stop to fit your bit
- Lubricant or silicon spray



#### **Ounce of Prevention**

If you can only find window pins that operate with a key, don't buy them; use bolts or nails instead. In case of fire or other emergency, you don't want to be looking for a misplaced key!

1. Fully close and lock the window you'll be drilling; you want the upper rail of the lower (inside) sash, and the lower rail of the upper (outside) sash to be parallel. (The double-hung window shown at the beginning of this chapter shows it in locked position.)
2. You don't want to drill through both sashes completely, because this will enable someone to foil your security plan from outside! So measure the depth of the two sashes in locked position, and mark your drill bit to  $\frac{3}{4}$  of that measure with a piece of masking tape or a bit stop. You will stop drilling when the bit gets to this mark.
3. Find the center of the top left and top right corners of the lower sash; mark it with the awl or pencil; the awl is good for this mark, because it "grounds" the drill as you begin drilling. (Security pin hole locations are marked on the window illustration earlier in this chapter.)
4. Wearing safety goggles, hold the drill straight, drill into the window at the marks. Keep your grip firm, because you're drilling through two wood rails and possibly some weather stripping between them. Stop drilling when your bit is inserted to the stop or masking tape mark.
5. When both holes are drilled, lubricate your fasteners before you insert them in the holes. The fasteners should be a little loose so you can remove them easily.



## **The Least You Need to Know**

- ◆ Some sticky window problems are merely the result of sticky weather; don't apply invasive measures unless you must.
- ◆ Old wood windows that have lost their weights can still be controlled by installing devices in the channels.
- ◆ To fix screens mounted with splines, an exact duplicate material is needed.
- ◆ Window pins are a simple addition to your home's security.



## Doors: An Open-and-Shut Case

### In This Chapter

- ◆ Parts of a door
- ◆ Silencing the talkative door, and making the stubborn one respond
- ◆ Getting a grip on doorknobs with a couple of easy repairs
- ◆ Keeping balky sliders on track
- ◆ Installing a peephole in a windowless outer door

Do you have door slammers at your house? I do. They announce themselves with a bang, not a whimper, which is okay, except that our back door gets a workout. Screws loosen, the strike plate wobbles, and pretty soon it's time to get out the screwdriver for a couple of minor repairs.

Throughout her teenage years, our daughter would voice her displeasure with a resounding bang of her bedroom door. The last slam came when she broke one of the ancient hinges clear through its cast iron body—I believe the term is metal fatigue, and I'm sure it was very tired. Replacement hinges set Rachel back several weeks of allowance money, so she's become much gentler with doors ever since.

Even without a resident slammer, doors get a workout over the years, and some at your house may be showing signs of age or hard wear. This chapter will teach you all the important parts of doors, and how to make them swing to *your* rhythm—and eliminate wobbles, squeaks, drags, or rattles.

Of course, you can avoid many of these little repairs by insisting that all members of your household close doors with their hand *on* the knob: no slamming! It's the best preventive maintenance I can think of.

## Anatomy of a Door

You may notice some of the same words that are also used to describe a window. The *jamb* is the vertical part of the door frame—the opening in which the door is installed. The frame's top piece is called the *header*; the bottom piece is the *sill*. On exterior doors, the sill may have another piece over it that spans the sill; this is known as a saddle (not shown).

The door itself has horizontal parts, called the *rails*; and vertical parts, called *stiles*. The *hinge stile* is the vertical piece where hinges are attached; the *latch stile* is the vertical piece that holds the latch, doorknob, and/or lock, if there is one.

*Parts of a door:*

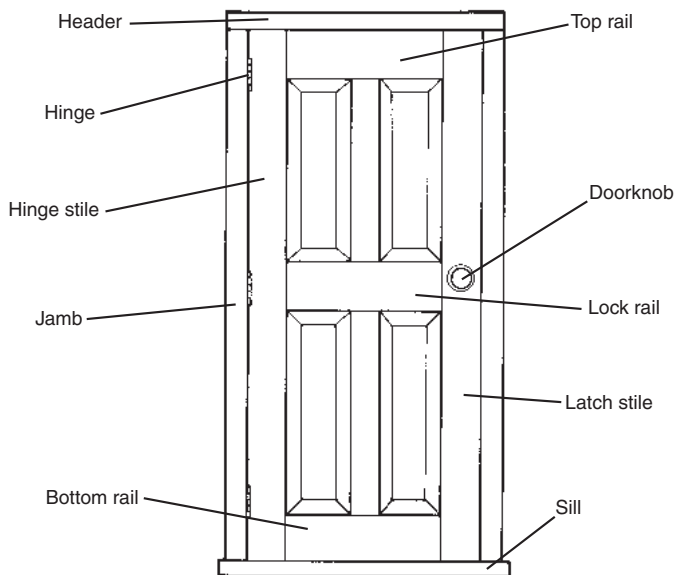



### What Pros Know

The previous illustration shows the door from the outside; because the hinges are on the left side of the door, it is known as a *left-handed* door. Looking at the door from the outside, doors that are hinged on the right are known as *right-handed* doors. Knowing whether a door is right- or left-handed is important if you are buying or replacing a doorknob that can be locked, also known as a lockset, that works with one or the other, but not both. Since you want the key to be on the outside of the door and the push- or turn-button lock on the inside, you need to buy a right- or left-handed lockset, depending upon the door in which it will be installed.

Many older doors are composed of rails, stiles, and panels, like the one shown in the illustration. Other, newer doors may not be solid wood; they may be made of thin layers of wood or metal applied over a core of rigid foam or other material.

## Silencing the Talking Door

A door that squeaks usually needs attention to its hinges—the metal hardware that attaches the door to its frame. There are lots of different kinds of hinges, but the principle is the same. The two sides of the hinge, called leaves, connect to each other by means of a pin threaded through interlocking knuckles.

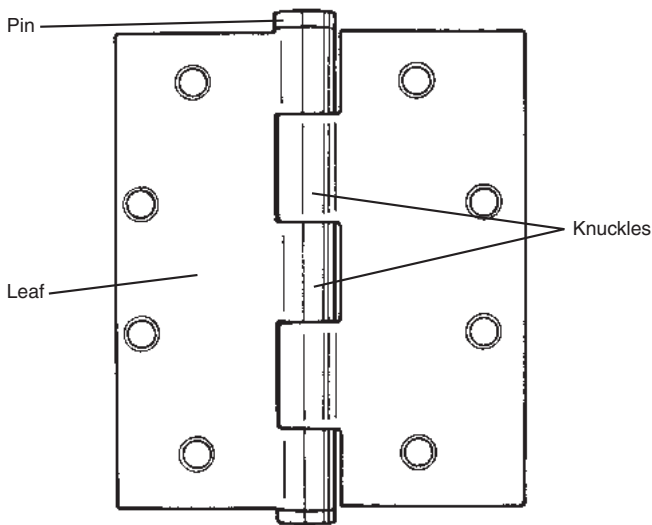

*Common door hinge.*

Squeaks are usually eliminated by applying a little lubricant—a penetrating oil is good, though some people have told me that vegetable oil is also effective!

You'll need the following:

- Newspaper to put under the hinges (oil can spot the carpet!)
  - Small-tipped nail set or thin-shanked standard screwdriver
  - Claw hammer
  - Can of penetrating oil or similar lubricant, equipped with a straw for applying a narrow stream
  - Clean rag or sponge
1. Lay newspaper under the door to protect the carpet. Open the door and look at the hinge. You'll want to lubricate the area where the pin meets the knuckles of the two hinge leaves.
  2. If you know which hinge is squeaking, start there. But lubricate all the hinges and you'll have silence longer!
  3. In most cases, you can loosen the pin by driving the nail set or screwdriver tip into the hole at the bottom of the hinge joint. Wearing safety goggles, use the hammer to drive the pin up from between the leaves an inch or so.
  4. Spray a little lubricant into the pin hole at the top, where the head of the pin has been raised. Give the oil a minute to seep down inside, around the pin and the knuckles. Wipe off any excess or drips of lubricant with your rag. Reset the pin and try the door.
  5. If the door is no longer squeaking, repeat this exercise with the other hinge or hinges. If it's still squeaking, drive up the first pin again and repeat Steps 2–4 until you achieve silence.

## Tightening Loose Hinges

Time, use, and wear can make two things that belong together—the hinge and its screws—come apart. Tighten screws as soon as you notice they are loose. The longer loose screws are left untightened, the greater the likelihood that they'll widen the screw holes or wear (strip) the screw threads and need replacement. Because of the law of gravity—the weight of the door that the hinges support—the top hinge will most likely exhibit loose screws first.

If you've got loose screws, here are a couple of suggestions.

## Fix #1: Gum Up the Holes

This quick fix will work for repairing loose screw holes for hinges of lighter-weight doors. For heavy doors, skip to Fix #2.

You'll need the following:

- Screwdriver (standard or Phillips, whichever fits)
  - Book of cardboard matches
  - Wood glue
  - Utility knife
1. Open the door wide and wedge something under it so the door's weight won't stress the hinge.
  2. Remove the loose screw or screws from the hinge leaf. Dip one or two cardboard matches in the wood glue and put them in the loose screw hole. Cut away any bits of matchstick that stick out of the hole with the utility knife. Reinsert the screws and tighten.

## Fix #2: Longer Screws

If you already have the right-size fasteners, this is even easier than Fix #1.

You'll need the following:

- Screwdriver
  - 2 1/2" wood screws, same diameter as the old ones (you may want to use Phillips head screws rather than standard head screws; most people think they're easier to tighten and loosen)
1. Prop up the open door as in Fix #1.
  2. Replace the loose screws one by one.



### What Pros Know

When you go to the hardware store and look at door hinges, you'll notice that the hinges are sold with fairly short screws. By using a longer screw, you'll fasten the hinge more deeply into the door jamb.

## Sticking Doors

Sometimes a door binds because the door itself is swollen from humidity; if binding doors are a problem in this kind of weather, you may want to lightly sand and refinish the latch edge of the door, particularly if the door is peeling paint—bare wood swells more than finished material. Or you can take the lazy strategy, and wait for cool weather. Several of the interior doors in my old New York house bind in summer when it's very warm and sticky; I just don't close them. They work perfectly in winter, when I want to keep them closed, anyway.

And sometimes, there's a bit of a hardware problem. If the hinges are loose, the door may bind along the latch jamb (the doorknob side). Tightening the hinge screws may cure the problem. Or the problem may be located on the opposite side of the door.

Open and close the door slowly, and look at the strike plate; that's the little square or rectangular gizmo that has a hole in its center (the strike) which holds the latch or bolt that's released when you let go of the doorknob and the door is shut. If the strike plate is loose (continual slamming can loosen it!), get out your screwdriver and try Fix #1 or #2 described previously to tighten the screws into the latch jamb.

*Strike plate.*

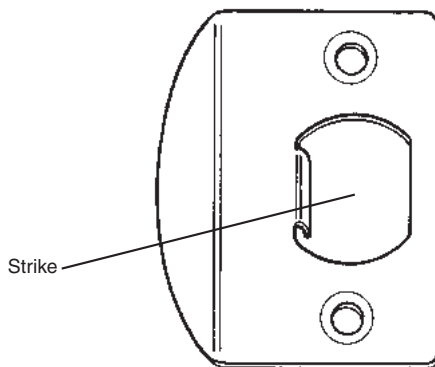

## Doors That Won't Stay Closed

First, test the doorknob; the latch or bolt that fits into the strike plate may be sticking, and thus not releasing and engaging with the strike. You can probably fix this by lubricating the latch with a little graphite or penetrating oil.



The tale of the mysterious shrinking door is actually not very mysterious. If the weather is cold and dry, or if the humidity level in your house is very low, a wooden door will shrink in response. In turn, the latch or bolt may no longer engage with the strike, and the door won't close.

This is a job for shims! It's a good idea to use a fix that can be reversed, in case the door swells up again.

You'll need the following:

- Screwdriver (to match the strike plate screws)
- Cardboard (file folder stock makes good shims for this purpose)
- Pencil
- Scissors

On an interior door, shimming the strike plate works fine, and you don't have to mess with the hinges. Here's what you do.

1. Unscrew the strike plate and put the screws in a safe place so you don't lose track of them.
2. Trace the strike plate on cardboard; make a few copies. Cut out the cardboard templates.
3. Position one cardboard shim behind the strike plate, and screw the shim and plate back into its mortise. Then try the door. If the latch holds, you've solved the problem. If not, insert additional shims until the door closes properly.

On an exterior door, shimming out the strike plate can create a problem with door security. In this case, you can shim out the hinges. If you follow the direction suggested by the following illustration, you'll be able to shim the hinges without removing the door.

In addition to the tools and supplies listed for the strike plate shim fix, get a thin piece of paper so you can trace the outline of the hinge. You will also need something to support the door—wood blocks, shims, books—while you are tinkering with the hinges.

1. Open the door and, using pencil and paper, trace the outline of the hinge on the door jamb, including the screw positioning. Close the door when you're done and continue to Steps 2 and 3.

2. Using the tracing as a template, make a couple of cardboard shims for each door hinge (many modern doors have two hinges; others three, some four).
3. Cut the hinge shim like the illustration, with slots cut to the edge of the template so you can slide the shim under loosened screws.

*Placing a cardboard shim behind a hinge may fix a door that won't stay closed.*

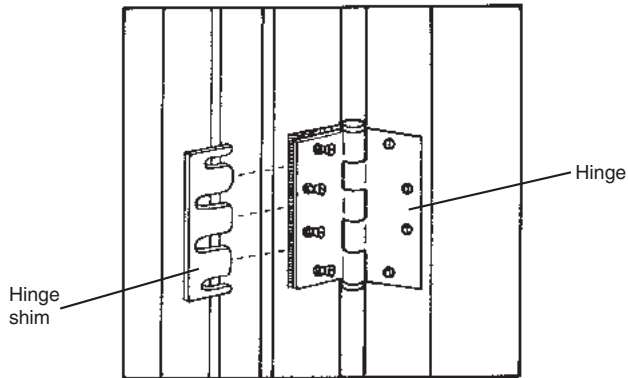

4. Open the door wide, exposing the jamb side of the hinge. Loosen one hinge at a time, slide in a shim, and tighten; shim all the hinges. Add shims until the door latches properly.

## Getting a Grip on Doorknobs

There are four basic types of doorknobs:

1. *Dummy* doorknobs don't turn and are often used just for appearance.
2. *Passage* doorknobs turn, but have no keys or locks; these are often used in children's bedrooms or playrooms where a locking door could be a problem.
3. *Privacy* doorknobs lock and can be unlocked only from the inside; these are good for adult bedrooms and bathrooms. If someone should accidentally lock themselves in, you can quickly free them (see how later in this chapter).
4. *Keyed entry* doorknobs mean what they say; to gain entrance, you must unlock them with a key.

## Tighten a Loose Knob

Modern doorknobs—the ones you’ll find in a house that’s less than fifty or sixty years old—are fairly simple to tighten. On these models, the whole works may be jiggling—from trim to knob. Usually you’ll find two surface-mounted screws on the face of the inside doorknob trim piece that is mounted flush with the door—it’s traditionally called a rose. Sometimes the screws are concealed under the trim piece. In this case, you’ll have to pry off the trim piece to get to the screws. The screws actually pass all the way through the door to the trim piece on the other side.

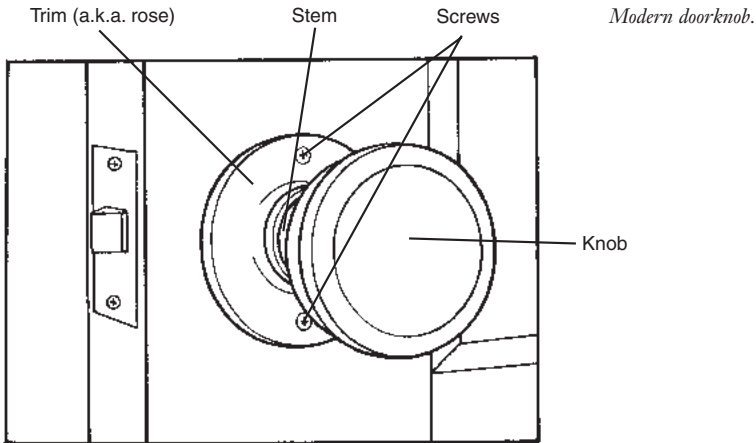

You’ll need the following:

- ❑ Screwdriver (Phillips or standard, to match the screws)
- ❑ Utility knife (if you need to score the paint around the trim piece to remove it)
- ❑ Small pry bar or standard screwdriver to remove trim piece, if the screws are underneath



### Ounce of Prevention

Careless painters may have painted the edge of the trim piece where it meets the door. If your door trim is paint-bound, use a utility knife to carefully score the paint around the rose so you won’t mess up the surface of the door by hacking away at it with the screwdriver.

Only one step here—tighten the screws. Hold both trim pieces tight to the door with one hand as you tighten the screws with the other. Tighten the screw closest to the edge of the door first.

The house I grew up in (circa 1940), and the one I live in now (“renovated” in the 1870s), have old-style doorknobs. You may have them, too. Instead of two screws passing through the lock cylinder to the other side of the door, there is a square metal spindle with threads on both ends that passes through the rose. The spindles are covered on both sides of the door with little metal shanks; the knobs (usually) onto the spindle at each threaded end. All of this is held in place by means of a single set screw in each of the two shanks. The screw threads through the shank and tightens against the spindle on one of its four flat surfaces.

*Old-style doorknob.*

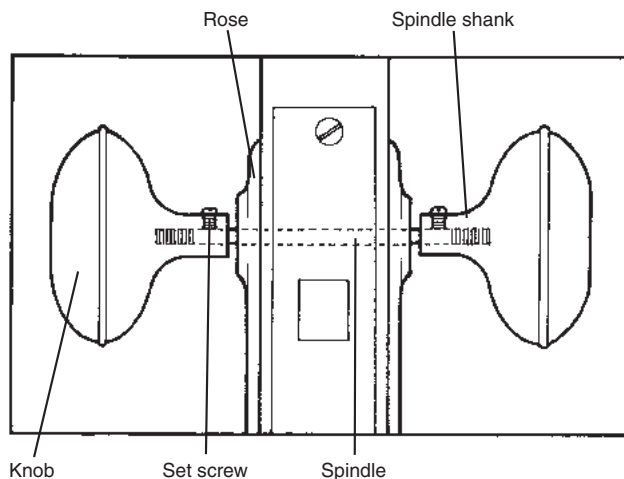

Wobbles happen when the set screw gets loose, or disappears. You may have to hunt for a replacement screw (see Appendix B for a dealer in old hardware), but these antique knobs are often beautiful, made of glass, bronze, chrome (1930s), or nicely aged and worn wood. They’re worth saving—or selling to someone who likes them!

You’ll need the following:

- ❑ Standard screwdriver—make sure it’s the right size or you may deform the set screw head; some late-model (1940s and after) set screws may unscrew with a hex head (Allen wrench)
- ❑ Lubricating oil (penetrating oil, such as WD-40)

1. Loosen the set screw in the shank of the loose knob. If the screw is tight, don't force it! Lubricate the screw with a drop of lubricating oil, and then try to unscrew it.
2. Examine the screw. If the base (the opposite end from the head) looks deformed, it should be replaced. You can finish the repair once you have a new set screw.
3. If the screw is intact, check the set screw that holds the knob in place on the other side of the door. If it's tight, proceed.
4. Press the knob that still has its set screw in place tightly against the rose on the other side of the door. Turn the knob until one of the flat sides of the spindle is facing up through the set screw hole. Replace the set screw, tightening it firmly against the flat side of the spindle.
5. Operate the knob; you should be able to turn it freely.

## **Replacing a Passage, Privacy, or Keyed Entry Lockset**

It's fairly easy to replace a set of doorknobs and latch with a modern doorknob—the kind that attaches both knobs and engages the latch with two long screws. Remove the screws, and then the knobs and trim will pull out easily. Then take the old set to the store and purchase a new one by the same maker. The new set will install in the reverse order that you removed the old set. All it takes is the right screwdriver; on modern doorknob sets, usually a Phillips head. If the trim piece conceals the long screws, you'll need a standard (flat head) screwdriver or small pry bar to pry off the trim piece.

If you've got the old-style doorknobs in your house, replacement is more problematic, as these are not so standard. Refer to Appendix B for an old house parts supplier; they may have the parts or replacements to do the job, and they work by fax or e-mail to assist customers.

## **Screen and Storm Doors**

Having an extra door can be helpful. In winter, a glass-windowed storm door adds an extra layer of insulation to the door. Usually these doors have interchangeable storm and screen panels. In summer, when you change to screens, you can get a nice breeze going through your house when the entry doors are open and the screen doors are closed. One problem with these extra doors is that the screens can get torn or loose and need replacement. See Chapter 8 for instructions on repairing and replacing screens.

## Adjusting the Door Closer

The other problem with storm/screen doors is that they usually operate with a mechanical closer that may be too fast or too slow—either slapping into your ankles or letting in flies along with the person who’s coming or going. The good news is that this problem is incredibly easy to fix.

### def•i•ni•tion

**Pneumatic** refers to a tool or machine that is operated by compressed air.

Let’s take a look at the most common mechanical closer, the *pneumatic* variety. It looks a lot like a bicycle pump.

This device is attached to the hinge jamb and (usually) the top rail of the door. When you need to hold the door open, you can adjust the little washer shown in the illustration to keep the door in place; move the washer next to the tube when you want the door to close as usual.

*Pneumatic door closer.*

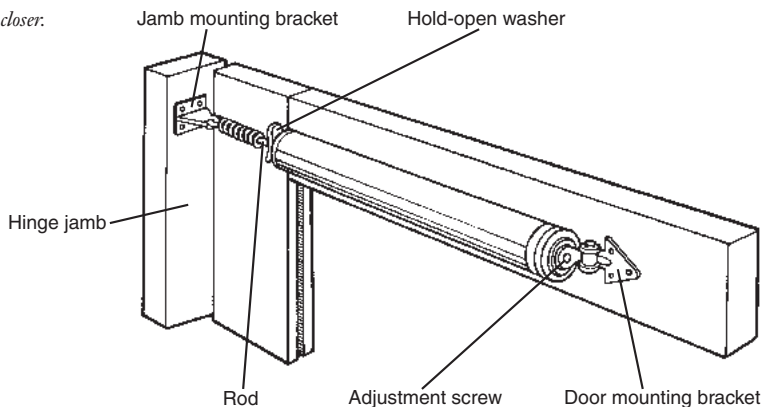

To slow down or speed up the closing action, you’ll need to use a Phillips or standard head screwdriver to turn the adjustment screw, usually located in the same position on the closer as the one shown in the illustration. To slow the closing action, turn the screw clockwise (righty, tighty). To speed up the door, turn the screw counterclockwise (lefty, loosey).

## If You Need a New Closer

These door closers have a long life span. But they eventually wear out, and installing a new one is very easy. If you can find a duplicate model, you can even use the same screw holes for the brackets. If you have to drill new holes, follow the closer package instructions, use a torpedo level to make sure the installation is level, and wear safety goggles when you drill the bracket holes.

Just be sure to put a stop or bit of masking tape on your drill bit at a length less than the door's thickness, so that you don't drill *through* the door!



### What Pros Know

When you install a door closer, you can position it anywhere on the screen door, as long as the jamb bracket is unobstructed by other hardware; however, it's generally attached along the top rail of the door, so it doesn't interfere or get tangled with people and things passing by.

## Lock and Key Dilemmas

Usually, your key fits in its corresponding lock, the door opens, no problem. But when glitches happen, here's what to do.

### Key Sticks in the Lock

If the key does not go smoothly into and out of the keyhole, you can put a little graphite on the key, and work it into the lock, or squeeze a little graphite into the keyhole, and do the same.

### Key Breaks Off in the Lock

This happens, but don't panic. Before you call the locksmith, try to grab whatever is still sticking out of the lock with locking or needlenose pliers. Pull *straight out*. If the key fragment won't budge, try squirting a little lubricant into the lock, and try again with the pliers. If this doesn't do it, or if you can't grip the key fragment that remains in the lock, you'll have to call the pro.

## Lock Is Frozen

This occasionally happens when there's been a lot of wet weather followed by bitter cold; the moisture freezes and can find its way into keyholes, too. Keep a small container of spray de-icer in your purse or other easily accessible place in the wintertime. Spray a little on the keyhole, and it should break the ice in seconds. I've also heard of people warming up the key with a hair dryer, but this isn't going to work if you're locked outside the house!

## Locked in (Privacy Lock)

If you have small children or live with elderly family members, the kids or seniors may occasionally lock themselves into a room that is accessed with a privacy doorknob set; that is, there's a locking mechanism on the inside of the door. They lock themselves in, and can't get themselves out. And there's no key on the exterior doorknob for you to unlock.

You can first try to coax your elderly relative or child to turn the little locking mechanism on the inside of the door to the "unlock" position. If that doesn't work, try the following fix. Assuming you have modern doorknobs, you can release them if you can locate a slot or hole on the exterior doorknob, or on the rose (trim piece) of the exterior doorknob. Use the tip of a metal nail file, or the point of a straightened paper clip to push straight into the hole or slot. This will probably open the door. If it doesn't, you'll have to call a locksmith.

While children are small, or seniors are living with you, consider changing from privacy to passage locks. My daughter locked herself in the bathroom when she was little, and the experience scared her enough that she didn't repeat it. However, kids and elders alone in the bathroom are always at risk for an accident while they're stuck.

## Installing a Peephole

If there is no way to see who's on the other side of your exterior door, it's a good idea to install a peephole. You should never open the door if you don't know the person who's there, or if the person will not identify himself/herself. You can buy peepholes in the section of the hardware or home center where locks, keys, and other door security equipment is sold. Look for one that has a vision field of 190°, which will permit the widest view of who's standing outside your door.



\* \* \* Free Preview End \* \* \*

Purchase Required To Gain Total Access

Visit [www.propmgmtforms.com](http://www.propmgmtforms.com) To Purchase *Property Management Forms* Package