

alpha
books

THE
COMPLETE
IDIOT'S
GUIDE® TO

"This is not just a manual for beginners—handymen and other advanced homeowners will find invaluable information and tips to make wiring faster, easier, and less expensive."

—Matthew Tirschwell,
President, Tirschwell
& Co., Inc.
Architectural
Lighting Design

Electrical Repair

- ◆ **Foolproof steps** for wiring every room in your home
- ◆ **Quick and easy guidelines** for dealing with electrical codes and inspections
- ◆ **Easy-to-follow advice** on staying safe while making electrical repairs

Terry Meany



THE
COMPLETE
IDIOT'S
GUIDE[®] TO

Electrical Repair

by Terry Meany

alpha
books

A member of Penguin Group (USA) Inc.

Copyright © 2000 by Terry Meany

All rights reserved. No part of this book shall be reproduced, stored in a retrieval system, or transmitted by any means, electronic, mechanical, photocopying, recording, or otherwise, without written permission from the publisher. No patent liability is assumed with respect to the use of the information contained herein. Although every precaution has been taken in the preparation of this book, the publisher and author assume no responsibility for errors or omissions. Neither is any liability assumed for damages resulting from the use of information contained herein. For information, address Alpha Books, 800 East 96th Street, Indianapolis, IN 46240.

THE COMPLETE IDIOT'S GUIDE TO and Design are registered trademarks of Penguin Group (USA) Inc.

International Standard Book Number: 0-7865-4938-6

Library of Congress Catalog Card Number: Available upon request.

06 05 04 8 7 6 5 4

Interpretation of the printing code: The rightmost number of the first series of numbers is the year of the book's printing; the rightmost number of the second series of numbers is the number of the book's printing. For example, a printing code of 00-1 shows that the first printing occurred in 2000.

Printed in the United States of America

Note: This publication contains the opinions and ideas of its author. It is intended to provide helpful and informative material on the subject matter covered. It is sold with the understanding that the author and publisher are not engaged in rendering professional services in the book. If the reader requires personal assistance or advice, a competent professional should be consulted.

The author and publisher specifically disclaim any responsibility for any liability, loss, or risk, personal or otherwise, which is incurred as a consequence, directly or indirectly, of the use and application of any of the contents of this book.

Publisher

Marie Butler-Knight

Product Manager

Phil Kitchel

Associate Managing Editor

Cari Luna

Acquisitions Editor

Randy Ladenheim-Gil

Development Editor

Alexander Goldman

Production Editor

Christy Wagner

Copy Editor

Amy Lepore

Illustrator

Jody Schaeffer

Cover Designers

Mike Freeland

Kevin Spear

Book Designers

Scott Cook and Amy Adams of DesignLab

Indexer

Brad Herriman

Layout/Proofreading

Fran Blauw

Mary Hunt

Liz Johnston

Contents at a Glance

Part 1: The Basics: Out of the Dark Ages	1
1 Fear of Frying <i>A brief intro to your electrical system.</i>	3
2 What Is Electricity Anyway? <i>The why, how, and where of electricity.</i>	15
3 History Lessons <i>Electricity has always been around, but it took a lot of smart guys to harness it and make it useful.</i>	27
4 If Your Walls Could Talk <i>Codes, inspectors, and a closer look at your wiring.</i>	39
5 More Wall Talk <i>Your wiring shouldn't be a puzzle; all you need to do is understand the pieces and how they go together.</i>	53
6 When You Buy a House <i>How to be an electrically smart buyer when you go house hunting.</i>	67
Part 2: Safety, Tools, and Contractors	81
7 Caution Signs and Safety Concerns <i>Electrical shocks can be more than shocking; here's how to avoid them.</i>	83
8 Call Me Sparky <i>To do your own electrical work, you should look at the job the way an electrician would.</i>	97
9 Extension Cords and Multiple Strips <i>A great convenience—as long as you don't abuse them.</i>	111
10 Electing for Electricians <i>What to look for in, and expect from, a qualified electrician.</i>	125
Part 3: Components and Simple Repairs	135
11 Switches and Receptacles <i>Telling the difference from one type to another.</i>	137
12 Replacing Old Switches and Receptacles <i>Simple repairs to get you started.</i>	149
13 Lighting Up <i>From bare-bulb fixtures to halogen lamps, there's a light for every purpose.</i>	171
14 Light Fixes <i>You don't need to live in the dark if you know how to repair your lights.</i>	187
15 Working Around Existing Wiring <i>Here are some guidelines for accessing and tying into your system.</i>	205

16	Trouble, Troubleshooting, and Safety <i>Avoiding bigger problems later by staying out of trouble now.</i>	223
Part 4: Power Hungry		233
17	Service with an Attitude <i>More power to you when you upgrade to a new service panel.</i>	235
18	Adding New Circuits <i>Additional power calls for more circuits; here's how to add them.</i>	247
19	Kitchen Power <i>Cooking should be convenient, and new kitchen wiring goes a long way toward accomplishing that.</i>	251
20	Bathroom Wiring <i>Water and electricity can mix if you follow the rules.</i>	263
21	The Great Outdoors <i>You don't need to limit your electrical work to the indoors when you have a whole yard to light up.</i>	275
22	Electric Heat and Air Conditioning <i>There's more than one way to get some cool comfort or winter warmth from your electrical system.</i>	287
Part 5: Refinements		299
23	Workshops, Offices, and Generators <i>Extending your system after you're finished with the basics.</i>	301
24	Your Own Hi-Tech Revolution <i>Power at your fingertips when you wire for remote controls and media madness.</i>	317
25	Alarms, Detectors, and Security <i>Protecting your family and your home from smoke, fire, and intruders.</i>	333
26	More Low-Voltage Wiring <i>Intercoms, doorbells, and thermostats help complete your wired world at home.</i>	349
27	A Few Alternatives <i>Accessing electricity is great, but saving energy can be a big plus, especially with your utility bill.</i>	359
28	Putting It All Together <i>Looking at the big picture.</i>	373
Appendixes		
A	Resources	385
B	Glossary	387
	Index	391

Contents

Part 1: The Basics: Out of the Dark Ages 1

1 Fear of Frying 3

A Wired World	4
<i>Linear Logic</i>	4
<i>Follow the Electrical Code</i>	5
<i>Safety Rules, Mr./Ms. Homeowner</i>	5
<i>Mutual Respect</i>	6
Do It Yourself or Hire It Out?	6
<i>Drilling and Pulling</i>	7
<i>Neatness Counts</i>	8
<i>Simple Projects First</i>	9
System Checkup	9
<i>Plugless in Seattle</i>	9
<i>Let There Be Light</i>	10
<i>Hot Spots</i>	10
<i>Special Needs</i>	10
Confused About Fuses?	11
Circuit Breakers	12
More Power to the People	12

2 What Is Electricity Anyway? 15

Go with the Flow	16
Staying Current	17
<i>AC/DC</i>	17
<i>You're Grounded</i>	18
Voltage Provides the Push	19
<i>Know Your Volts: 120/240</i>	20
<i>Amps for Short</i>	20
Watt's That?	21
<i>Wattage Around the House</i>	21
<i>This Joule Isn't a Gemstone</i>	22
Resistance Isn't Futile	22
<i>All Wire Isn't Created Equal</i>	23
<i>No Substituting</i>	25

3 History Lessons 27

An International Effort	28
The Pioneers	28
<i>Ben Franklin Flies a Kite</i>	28
<i>Galvani's Frog Legs</i>	29
<i>Watt</i>	29
<i>The Amp Man</i>	29
<i>Oompa-Ohm</i>	30
<i>Coulomb Was Très Cool</i>	30
<i>Other Electrical Fellows</i>	31
Edison, Mega-Inventor	31
<i>Let There Be Light</i>	32
<i>Our First Big Power Plant</i>	33
Tesla Needed a Lawyer	33
Early Safety Measures	34
The Standards Change	35
<i>Fuses to Breakers</i>	35
<i>Just One Ceiling Light</i>	35
Knob-and-Tube Wiring	36
Wiring Evolves	36
Creeping Home Power Demands	37

4 If Your Walls Could Talk 39

The National Electrical Code	40
<i>You and the Code</i>	41
<i>Local Rules, Local Inspectors</i>	41
<i>The CEC</i>	42
<i>Underwriters Laboratory</i>	43
Are You Up-to-Date?	44
<i>Two-Wire and Three-Wire Systems</i>	44
<i>Feeling Polarized</i>	45
Circuit Breakers vs. Fuses	46
<i>This One Blows</i>	47
<i>This One Trips</i>	47
<i>The Main Shutoff</i>	48
The More Power the Better	49
<i>Look to Future Needs</i>	49
<i>Cost Comparisons</i>	49
<i>Panels and More Panels</i>	50

5 More Wall Talk 53

Branching Out to Break Up the Load54
 Amps, Watts, and Wire Gauge Working Together54
 Circuits and Runs56
 Know Your Circuits with a Circuit Map57
 What Are Friends For?58
GFCIs—Ground-Fault Circuit Interrupters58
Wire Systems Old and New60
Do You Need to Replace?61
 Jump Up to 200 Amps61
 Good Wire, Bad Wiring62
 When New and Old Collide62
Location, Location64
Your Checklist64

6 When You Buy a House 67

Caveat Emptor or Buyer Beware!68
 Who Does the Inspection?68
 The Preliminaries68
 Testing! Testing!69
 The Other Tool You Need71
 Smoke Alarms72
Aluminum Wiring72
 What's the Story?73
 What You Should Look For74
 Warning: Aluminum Wiring Ahead75
 Solutions75
The Great Outdoors77
Attic Insulation Problems77
A Breath of Fresh Air78
More Testing78
Some Final Points79

Part 2 Safety, Tools, and Contractors 81

7 Caution Signs and Safety Concerns 83

Shocks Galore84
 When You Can't Let Go84
 How Much Can You Take?85
 Timing Is Everything86

Know Your First Aid	86
<i>The Source of the Problem</i>	87
Quiz #1	87
Safe Work Practices	89
<i>Turn It Off!</i>	89
<i>One Hand Behind Your Back</i>	90
<i>Test, Test, Test</i>	90
<i>On Dry Ground</i>	90
<i>Watch That Ladder</i>	90
<i>Tool Health</i>	91
<i>A Lesson from Your Kids</i>	91
<i>Speaking of Kids</i>	91
Some Statistics	93
Electro Kindling	94
New Service Doesn't Let You Off the Hook	95
More Information	95
8 Call Me Sparky	97
An Electrician's Mindset	98
<i>Think Before You Drill</i>	99
<i>Minimum Damage, Minimum Repairs</i>	99
Permits	100
<i>Keeping the Inspector in Mind</i>	100
<i>The Code Calls the Shots</i>	101
<i>Insurance Issues</i>	101
Tools of the Trade	102
<i>Hand Tools</i>	102
<i>Power Tools</i>	103
<i>Care and Feeding of Power Tools</i>	106
<i>Bits</i>	107
<i>Rent or Buy?</i>	108
UL-Approved Parts for You	109
Home-Improvement Stores vs. Electrical Wholesalers ...	109
9 Extension Cords and Multiple Strips	111
Extension-Cord Protocol	112
<i>What the NEC Says</i>	112
<i>One Size Doesn't Fit All</i>	113
<i>When Cords Go Bad</i>	114

<i>Know the Rules</i>	115
<i>Homemade Cords</i>	116
Multiple-Outlet Devices	116
Surge-Suppression Devices	118
<i>What Do They Do?</i>	119
<i>Computers Aren't Very Tough</i>	120
<i>Suppressors for Everyone</i>	121
<i>Speaking About Computers</i>	122
<i>More Rules</i>	122
<i>Going Whole Hog</i>	122

10 Electing for Electricians 125

Hiring It Out	126
<i>Contracting for a Contractor</i>	126
<i>License and Bonding Spoken Here</i>	127
<i>The Name's Bond, Surety Bond</i>	127
<i>Insurance Is a Must</i>	128
<i>Three in One</i>	129
Plans and Specifications—Always!	129
<i>Who Draws Them Up?</i>	130
<i>Allowing Substitutions</i>	131
<i>Comparing Bids</i>	131
About Those Contracts	131
<i>Write It Down</i>	131
<i>Change Orders</i>	132
<i>A Deal's a Deal</i>	132
Cleanup and Wall-Repair Woes	133
<i>Electricians Hate Plaster Walls</i>	134
<i>Fire Blocks</i>	134

Part 3 Components and Simple Repairs 135

11 Switches and Receptacles 137

There's One for Every Purpose	138
Switches	139
<i>Three-Way Switch</i>	139
<i>Four-Way Switch</i>	139
<i>Switch/Receptacle Combo</i>	140
<i>Ganging Up</i>	141
<i>Pilot-Light Switch</i>	141

<i>Dimmers</i>	141
<i>Timers and Doorbells</i>	142
Receptacles Galore	142
Don't Forget the Boxes	143
<i>They're Not All the Same</i>	143
<i>Plastic or Steel?</i>	145
<i>Check the Size</i>	145
Cover 'Em Up	146
<i>Brass: New and Old</i>	147
<i>The Artful Flare of Ceramics</i>	147
12 Replacing Old Switches and Receptacles	149
Probing the Problem	150
Checking the Devices	151
Continuity Coming Up	153
<i>New Switches</i>	154
<i>Three-Way Switch</i>	157
<i>Four-Way Switch</i>	159
<i>The Great Outdoors</i>	161
<i>Dimmers</i>	161
<i>Old Wire, New Switch</i>	161
Disreputable Receptacles	162
<i>Check and Check Again</i>	162
Test for Grounding	164
<i>Two-Wire Grounding</i>	165
<i>Installing a New Receptacle</i>	166
<i>Grounding an Old Receptacle</i>	168
<i>Aluminum Wiring</i>	169
13 Lighting Up	171
How Illuminating	172
Measuring Your Lighting Needs	173
<i>Distinguishing a Lumen from Illuminance</i>	174
<i>Know Your Lighting</i>	175
<i>Aim High, Low, and Wide</i>	176
<i>Lighting Up Outside</i>	176
<i>Combining Lighting Styles</i>	178
<i>Looks Are Something</i>	181
What's Your Type?	181
<i>Incandescent</i>	182

<i>Tungsten-Halogen Lamps</i>	182
<i>Fluorescent Lighting</i>	183
<i>When Cheap Power Reigns</i>	184
Other Considerations	185

14 Light Fixes 187

Inspect First	188
<i>Time to Replace</i>	190
<i>Installing a Box</i>	191
<i>Try a New Style</i>	193
Fluorescent Fun	194
<i>The Pieces Inside</i>	194
<i>Even More Efficiency</i>	195
<i>Fluorescent Woes</i>	195
Lamps	199
<i>The Easy Repairs</i>	199
<i>Bugged by Bad Plugs</i>	200
<i>Round-Cord Plugs</i>	201
<i>Sock It to Your Socket</i>	202
A Dose of Reality	202

15 Working Around Existing Wiring 205

The Dangers of Overextending Yourself	206
<i>Your Total Load</i>	206
<i>Don't Estimate, Calculate!</i>	208
Leave Dedicated Circuits Alone	208
Uh-Oh, Old Wiring	209
<i>Mixing Old and New Wiring</i>	209
<i>How Much You Can Keep?</i>	210
Walls Everywhere	211
Boxes and the Code	215
<i>The Perils of Plaster</i>	215
<i>Drywall</i>	216
<i>Boxes in Ceilings</i>	216
<i>No Access, Now What?</i>	217
<i>The Woodwork Comes Off</i>	218
<i>Get Your Drill Out</i>	218
<i>Insulation Obstacles</i>	218
The Finish Work	219
Fitting All Those Wires In	219
<i>Plaster and Drywall Repair</i>	220

16 Trouble, Troubleshooting, and Safety 223

The Rules Once More	224
Warning Signs	225
<i>Hot Stuff</i>	225
<i>Short Circuits</i>	226
<i>Power Cords</i>	227
<i>Lamps</i>	227
<i>Incandescent Light Fixtures</i>	227
<i>Fluorescent Woes</i>	228
<i>Fire Hazards</i>	228
<i>Don't Overextend with Extension Cords</i>	229
<i>Regular Tests You Should Do</i>	229
General Precautions	230
Power Outages	231

Part 4 Power Hungry 233
17 Service with an Attitude 235

One New Service Coming Up	236
Overhead and Exposed	236
<i>Going Underground</i>	239
<i>New Service/Old Service</i>	239
<i>Fuse Box Becomes Junction Box</i>	239
<i>New Panel, Old Panel</i>	240
Anatomy of a Panel	240
<i>Location Is Everything</i>	242
Grounding Your Panel	242
<i>Breaker, Breaker</i>	243
<i>Subpanels—a Real Convenience</i>	243
<i>Subpanel Alternatives</i>	244
<i>Subpanel Considerations</i>	244
What's This Going to Cost?	245

18 Adding New Circuits 247

Write Up a Plan	248
Power Everywhere	248
<i>15 Amps or 20?</i>	249
<i>Plenty of Dedicated Circuits</i>	249

Roping the House	250
Keeping the Inspections in Mind	250

19 Kitchen Power 251

The Well-Wired Kitchen	252
<i>Dedicated Circuits Everywhere</i>	252
<i>Small-Appliance Circuits and GFCIs</i>	253
<i>Wiring the Fridge</i>	254
<i>Two More Exceptions</i>	255
<i>Ranges and Ovens</i>	255
<i>Disposers</i>	255
<i>Dishwashers</i>	256
<i>Big Appliances: Stovetop and Range</i>	257
Keep or Replace Your Appliances?	258
Lighting the Way	258
<i>Work Lights</i>	259
<i>Accent Lighting</i>	259
<i>Lots-o-Switches</i>	259
Ventilation	260
<i>You Have a Choice</i>	260
<i>Up and Out, Down and Through</i>	260
<i>Bigger Is Better</i>	261
Wiring Concerns	262

20 Bathroom Wiring 263

GFCI Is a Must	264
Installing the Fan	265
<i>How to Size It</i>	266
<i>Roof or Wall Vent?</i>	266
<i>So Many Different Switches</i>	266
It's Cold in Here	267
<i>Baseboard Heating and Forced Air</i>	268
<i>Heated Floors</i>	268
<i>Heat Lamps</i>	268
<i>Some Codes Don't Like Electric Heat</i>	269
<i>More Bathroom Toys</i>	269
<i>The Luxury of Warm Towels</i>	269
<i>Fog Be Gone</i>	269
<i>On-Demand Hot Water</i>	270

<i>Bathroom Lighting</i>	270
Incandescent Fixtures	270
<i>A Possible Laundry Room?</i>	272

21 The Great Outdoors 275

Light Up the Night	276
<i>Light Pollution</i>	276
<i>Other Concerns</i>	278
<i>Drilling and Digging</i>	279
<i>Metal and Plastic</i>	280
<i>You Can't Use Cable</i>	280
<i>Dig It</i>	281
<i>The Job So Far</i>	281
Draw Up a Plan	282
Skip the Digging	282
<i>Light Options</i>	283
<i>Low-Key Low Voltage</i>	283
<i>Fiber Optics</i>	284
<i>120-Volt Lights</i>	284
<i>Fancy Fixtures</i>	285

22 Electric Heat and Air Conditioning 287

Electric Furnaces	288
<i>Seal Those Ducts</i>	289
<i>Zone In</i>	290
<i>Hooking Them Up</i>	291
<i>Heaters with Receptacles</i>	291
<i>Going Portable</i>	291
<i>Radiant Heating</i>	292
Heat Pumps	292
Whole-House Ventilation	293
<i>Air Conditioning</i>	293
<i>Air-Conditioning Alternatives</i>	294
<i>Shade</i>	294
<i>New Construction</i>	295
Hot-Water Heaters, Big and Small	295
<i>Mixing Water and Electricity</i>	296
<i>Hot Water on Demand</i>	296

Part 5 Refinements 299

23 Workshops, Offices, and Generators 301

Workshops	302
<i>Woodshop Details</i>	302
<i>Raceways or Cable?</i>	303
<i>Safety Power Controls</i>	303
<i>Lighting Your Workroom</i>	304
<i>A Breath of Fresh Air</i>	304
Home Offices	305
<i>Beyond Manual Typewriters</i>	305
<i>Voice and Data Coming Through</i>	306
<i>Conduit for Future Options</i>	307
<i>How Fast Can You Go?</i>	307
<i>The Need to Suppress</i>	308
An Outside Job: Raceways	308
<i>It's a Wiremold World</i>	309
Generators	310
The Mechanics of a Generator	311
<i>Resistive and Reactive Loads</i>	312
<i>Read the Manual</i>	314

24 Your Own Hi-Tech Revolution 317

<i>The Automated Home</i>	318
A Wealth of Possibilities	319
Decisions, Decisions	321
Mixing and Matching	322
Speed Demons and Slowpokes	322
<i>Coax Dance</i>	324
<i>Look Ma, No Wires</i>	325
Hedging Your Wiring Bets	325
<i>Staying Alive with Cat 5</i>	325
<i>Cooperating with Coaxial Cable</i>	327
<i>Fiber-Optic Cable</i>	327
<i>Package Deal</i>	327
<i>X-10, an Original</i>	328
The Installation	328
<i>Staying in the Closet</i>	329
<i>Jacks Here, Jacks Everywhere</i>	329
<i>Is It Worth the Trouble?</i>	330

25 Alarms, Detectors, and Security 333

A Class 2 Act	334
Alarm Systems	334
<i>To Monitor or Not To Monitor</i>	335
<i>False Alarm</i>	335
<i>Hard Wired or Wireless?</i>	336
<i>Wireless Is Almost Effortless</i>	337
<i>X-10 System</i>	338
<i>Driveway Alarms</i>	338
<i>We're Watching You</i>	338
<i>Some Oddball Alarms</i>	339
<i>Installation Issues</i>	340
Smoke Detectors	341
<i>Wireless or Hard Wired?</i>	342
<i>Photoelectric or Ionization?</i>	343
<i>The Law</i>	344
What About Carbon Monoxide?	344
<i>Smoke and Heat: Install Both?</i>	346
<i>What's Safe Enough?</i>	346

26 More Low-Voltage Wiring 349

No Escaping Mom with an Intercom	350
<i>Phone-Based Systems</i>	350
<i>Hard-Wired Intercoms</i>	350
<i>Wireless Intercoms</i>	351
<i>Video Door Phones</i>	351
<i>Ding Dong, Door Chimes</i>	352
<i>Wired to Ring</i>	352
<i>Chimes</i>	353
<i>Wireless Chimes</i>	353
<i>Wiring for One or Two Buttons</i>	354
<i>Troubleshooting an Existing Doorbell</i>	354
Thermostats	355
<i>Thermostat Replacement</i>	356
<i>Wireless Thermostats</i>	357
The Wired World at Home	357

27 A Few Alternatives	359
Conserve and Save	360
Watts Add Up, Doc	360
<i>Energy-Efficient Lighting</i>	361
Heating	362
Thermostats	362
Air-Conditioning Alternatives	363
<i>Improving Your Air Conditioning</i>	364
<i>Sizing Up Your Air Conditioner</i>	365
<i>Time to Get Efficient</i>	365
Cool Your Hot-Water Costs	366
<i>Drips and Flows</i>	366
<i>The Appliances</i>	366
<i>Your Hot-Water Tank</i>	367
Keeping the Outdoors Outdoors	367
<i>Look Through Any Window</i>	368
<i>Insulation</i>	368
Here Comes the Sun	368
Is It Worth It?	369
Resources	370
28 Putting It All Together	373
How Far Do You Go?	374
<i>Time and Money Considerations</i>	375
<i>Added Value</i>	375
<i>Convenience</i>	376
Estimating the Job	376
A Realistic Time Frame	378
Sample Jobs	378
Hiring an Electrician	382
A Resources	385
B Glossary	387
Index	391

Foreword

Some years back (in high school as a matter of fact) I was involved with the technical side of the drama department. On one particular occasion, while we were hanging and testing lighting fixtures, I happened to look over to one of my classmates, who was grasping a fixture and the steel railing unusually tightly, and whose hair was defying certain laws of gravity.

He was the recipient of a few spare volts from a lighting fixture that was not properly grounded. It was probably at that moment that I developed a great respect for electricity. (My classmate suffered no long-term damage—though he did become an actor ...)

After many years working in theatre and architecture, I have seen bizarre electrical work—some by homeowners, some by electricians. What separates good electrical work from the bizarre is the cleanliness of the job. I know one electrician who, if he nicks a piece of cable anywhere along its run, will pull it out and start over, no matter how long the run. It is that attention to detail, that striving for perfection, that makes him such a good electrician. He understands that there is little room for error. You should follow similar standards.

Electricity has simple rules—this manual gives you a good insight into those rules. Please consider reading the entire book before you jump into a single project. There are so many good tips spread throughout the manual. Two most important things: 1) Turn off the power before you do any work. Resetting the clocks is much easier than resetting your cranium. 2) Know your limitations. If you have any doubts, call a licensed electrician.

A good plan is also helpful for your projects. All electricians work from blueprints. Drawings help to organize the whole project. A good electrician will have a number of drawings and will outline exactly how wires will be pulled throughout the project. This advance work can save hours of frustration and repair time spent on extraneous holes in walls.

And please don't underestimate the power of new lighting. Chapters 13 and 20 provide examples of ways to beautify your home. Just by changing your standard household screw-in light bulb to a directional PAR lamp you can change the entire appearance of your environment. Additional lighting on work surfaces can improve vision and make tasks easier.

The Complete Idiot's Guide to Electrical Repair is like no other reference manual. I teach Lighting Design at New York's Fashion Institute of Technology, and in the past when it came to teaching about electricity, no book existed that so clearly and thoroughly covered electricity and wiring. I am pleased to put *The Complete Idiot's Guide to Electrical Repair* on my list of textbooks. This is not just a manual for beginners—handymen and other advanced homeowners will find invaluable information and tips to make wiring faster, easier, and less expensive.

I wish you all good fortune on your future projects, and don't forget to secure the ground wire.

Matthew Tirschwell
President
Tirschwell & Co., Inc.
Architectural Lighting Design

Introduction

Electrical wiring, fixtures, and appliances have been part of our homes for almost a century, and they've been a wonder, unless your system is almost a century old! Then you have to wonder if it's safe, let alone satisfactory to meet the demands of a modern lifestyle. Even if you have a newer system, you may still want to make additions to it and extend its capabilities. In principle, this is just another remodeling job, but we treat wiring differently. Adding a circuit isn't the same as adding a cabinet.

A poorly planned or installed cabinet won't shock you or create a fire hazard. Nor does it require a permit and an inspection. You can hang it crooked or hang it over a water pipe, and it will still do its job. Electrical work isn't so easy, but it isn't incomprehensibly difficult, either.

Many of us have little understanding of our electrical systems, or electricity itself for that matter, so we call electricians when we can't figure out why the lights keep going out or when we want to add a receptacle to a bedroom. Even in an age of supermoms and multitasking dads, we can't know how to do everything, but does electrical wiring need to be all that daunting? No, it does not, as you'll see by the time you've finished reading this book.

Big jobs, like installing a new electrical service, are usually best left to professional electricians, but anyone with a few tools, some elementary math skills, and a free weekend can add a circuit or replace old light fixtures. Wiring is a relentlessly logical process (well, that and a lot of drilling and pulling). The rules are clearly spelled out and easy to follow. You can put away your unwarranted fears about electricity—but not your precautions—and safely do much of your own work.

The chapters that follow will give you a better understanding of just what electricity is and how wiring systems work. We'll walk through the steps for everything from replacing a switch to wiring a bathroom. As you read, the mystery will slowly wear off as you start planning more lights, receptacles, and upgrades. You can even automate your house and set it up like one of the bad guy's fortresses in a James Bond movie.

Like any remodeling project, upgrading or adding on to your electrical system will require planning and a budget, at least for the bigger jobs. Large jobs, such as rewiring the bulk of your house, should be broken down into smaller jobs so they're less overwhelming. If you try to do too much at once, it's easy to find yourself with a jumble of wires, all of your circuits disconnected, and the end of the day approaching. Remember, you're learning some new skills. You won't become a master electrician overnight.

Electrical work brings some secondary tasks along with it. In some cases, you'll have to open up your walls and ceilings, and this means patching those holes later. Patching is usually followed by painting. It's tempting to let this go since it's surprisingly easy to let three or four years pass by looking at partially patched and unpainted walls. Be sure to give yourself enough time to complete the entire job.

Finally, remember why you're doing these projects: to make your home more comfortable, up-to-date, and safe.

How to Use This Book

Working on your house can be like raising children: Every day is an adventure. You want as few adventures as possible when you work around electrical wiring, though. In fact, one good-size adventure could be your last if you manage to shock yourself in a big way. Unlike other remodeling projects, electrical work is less broadly disruptive (you're not tearing out entire walls, for instance—at least, you'd better not be), which is a big plus.

This book is set up to give you a broad overview of electricity and systems first and follow up with actual projects, starting with the simplest. It's not an apprenticeship, but you'll have enough information to evaluate your system and make intelligent decisions about its condition and any need to upgrade. And you'll be a little more savvy when hiring an electrician.

Your work must always follow your local codes. Beyond that, you can add circuits and gadgets to your heart's content.

How this book is organized:

Part 1, “The Basics: Out of the Dark Ages”: Before you do any electrical project, you need to know how your system works, where all those wires go, and what a service panel does. Snoop around your panel or fuse box and check out all of your electrical devices so you'll know what you're dealing with.

Part 2, “Safety, Tools, and Contractors”: Many construction companies claim that safety is their first concern, and it should be yours, too, especially when you work around electricity. The right tools are always a must, whether you buy, borrow, or rent them. A few words about contractors are included here, too, should you decide to hire the work out.

Part 3, “Components and Simple Repairs”: You have to start somewhere, so I'll start with defining switches, receptacles, and fixtures and then discuss how to repair and replace them. Troubleshooting skills will make some repairs easier and faster.

Part 4, “Power Hungry”: Part 4 deals with the big jobs: a new service panel and running circuits to kitchens, bathrooms, and outdoors. If you don't have gas or oil, you should read about electric heat (air conditioning, too).

Part 5, “Refinements”: Once you've taken care of the basics, you'll want to do more. Workrooms, low-voltage wiring, and security systems all have their say in this part. And who doesn't need a doorbell? Finally, a few thoughts on conserving electricity.

Acknowledgments

Few books are solo efforts, and this one is no exception. I'd like to credit everyone whose generous efforts and contributions helped bring this manuscript together.

I'd like to thank my technical editor, Don Harper, who corrected me on more than a few occasions. When I least expected it, a fax would come over the line with the relevant electrical code and his notations on it.

Images are everything in a how-to book, and I am grateful for the artwork provided by Pamela Winikoff at Leviton; Raymond Venzon of Makita USA; Mike Mangan of MKM Communications; Joyce Simon at Western Forge (for Craftsman Tools); Pat Gengler (Milwaukee Electric Tool Corporation); Paige Malouche, Marketing Services Manager at Progress Lighting; the Wiremold Company; Saverio Mancinof Mintz & Hoke, Inc.; and Tom Monahan. Kibby Bowen, along with her husband, Brock, provided the black-and-white photography.

On the writing side, Randy Ladenheim-Gil at Alpha Books and Alex Goldman handled the editing and have my thanks for doing so.

Christy Wagner at Alpha Books put it all together.

Finally, my gratitude to my agent, Andre Abecassis of the Ann Elmo Agency, who keeps finding me such interesting assignments.

Special Thanks to the Technical Reviewer

The Complete Idiot's Guide to Electrical Repair was reviewed by an expert who double-checked the accuracy of what you'll learn here, to help us ensure that this book gives you everything you need to know about home electrical repair. Special thanks are extended to Don Harper.

Don Harper is a licensed Washington State electrical contractor and holds both an electrical administrator certificate and an electrical journeyman card. He is a graduate of the Construction Institute Trades Council and has taught first-year electrical classes there for seven years. His company, Harper Electrical, does both new and remodeled residential wiring as well as installations for high-tech communication and software companies.

Trademarks

All terms mentioned in this book that are known to be or are suspected of being trademarks or service marks have been appropriately capitalized. Alpha Books and Penguin Group (USA) Inc. cannot attest to the accuracy of this information. Use of a term in this book should not be regarded as affecting the validity of any trademark or service mark.

Part 1

The Basics: Out of the Dark Ages

In many ways, life was much simpler before the advent of electricity. People slept longer—after all, there wasn't much else to do when it got dark—and worked fewer hours for this same reason. Candles and gaslights just didn't cut it when it came to providing safe, well-lit working and living spaces.

In addition to lighting the way, electricity powers just about everything you touch and use. You should be able to enjoy all the benefits of a wired home—lights, receptacles, and the toys of civilization—wherever you want them. This is a doable goal regardless of the age of your house or its wiring. With some basic knowledge and understanding of your electrical system, you can surround yourself with power where you want it and have conveniences at your fingertips.

Before you start snipping away at your old knob-and-tube wiring, read through these first few chapters and get the basics. You'll find out how electricity flows from your local utility to your espresso maker in a safe, predictable manner and how you can keep it that way. All the wires running through your walls want to live an orderly life and have no interest in the anarchy of bad wiring jobs (which are not an uncommon problem in old homes, unfortunately). You don't want a future homeowner uncovering your work and wondering, "How could anyone wire like this?" It won't happen after you've gotten these chapters under your tool belt.

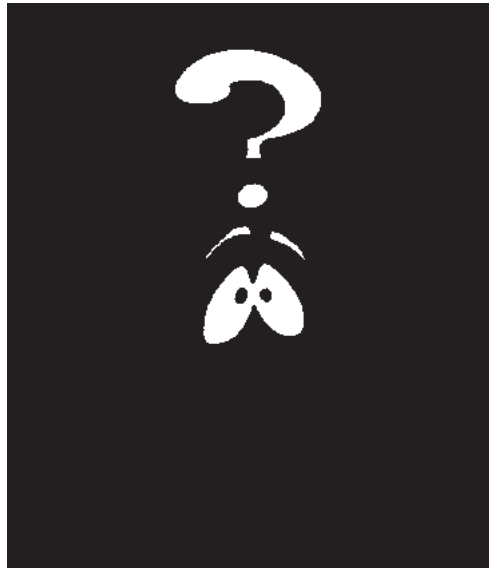

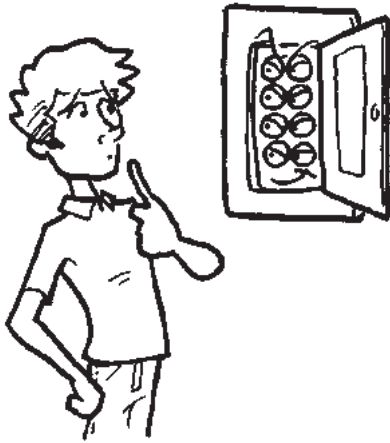

Fear of Frying

In This Chapter

- ▶ The logic behind your electrical system
- ▶ Getting the job done
- ▶ A brief inspection of your wiring
- ▶ Fuses and circuit breakers
- ▶ Running power where you want it

I once had a client who was installing some light fixtures in his Seattle home. While he was working, his mother called from New York. When told by her daughter-in-law what her son was doing, she screamed, “You tell him to get down. Doesn’t he remember what happened to Mr. Schneider down the street? He got electrocuted doing such things. What is he thinking, this son of mine?”

Mr. Schneider, it seems, didn’t know very much about electricity or his home’s wiring. Electricity isn’t some kind of barely contained liquid fire inside your wiring just waiting to strike and burn innocent victims. It’s a civilizing force in our lives that we won’t live without. Even when we go camping, we often take battery-powered gadgets so we can rough it in comfort.

This chapter will show you that your house’s wiring, if done correctly and legally, is a nice, logical system that should be respected, not feared. You’ll get a better feel for the work involved in upgrading or altering your system. You also will start to think about changes and improvements you might not have considered previously. Think of this as a bare-bones introduction to get you thinking about your electrical system and how to upgrade it.

You’ll also learn to do your work safely without worrying your mother too much.

A Wired World

We take electricity so much for granted that it's hard to believe many rural parts of this country lacked electrification until the 1930s. Now we have it in every room of the house, the garage, the basement, and even outdoors. Chapter 2, "What Is Electricity Anyway?" will get into the science of electricity. As a homeowner, what do you need to know before you start working on your wiring? What should you be looking for?

An electrical system is composed of a variety of parts, from those as large as a dam or another power generator to others as small as the wiring attached to your doorbell. The power coming into your house is much too powerful to use safely at full strength. Instead, it's broken down into smaller units through a system of circuits with breakers or fuses and different-size wires. Every component along the way has a role to play. Unlike income taxes, this is a very logical system.

Linear Logic

Left to its own devices, electricity wouldn't be much good to us because it requires some discipline to be useful. This discipline, in the form of electrical current, corrals the charged electrons that make electricity and directs them so they can power our lights, computers, and electric apple peelers. Your local utility company's generators produce the electricity and then "pipe" it to your home through wires and transformers. The only time this is of any great interest to you is when there's a disruption in the distribution system that results in your power going off and your digital clocks reverting to that annoying, flashing 12:00 signal when the power comes on again.



Electrical Elaboration

A utility company's circuits can get overloaded just as circuits can overload in our own homes. Too much demand for power to run fans and air conditioners during hot spells, for instance, can cause a loss of power for entire neighborhoods. Trees are another culprit. All it takes is one branch falling across some power lines to disrupt electrical service to anyone depending on those lines. For this reason, power companies maintain ongoing tree-trimming programs, which can be a difficult task in large rural areas. When a utility can foresee excessive, short-term demand, it might selectively shut down power if it can't purchase additional power from another utility.

Once the power lines enter your house, your interest naturally perks up. Here, the comfort and safety of you and your family are your number-one concerns.

Follow the Electrical Code

The installation of electrical systems in the United States is subject to local building codes. As a rule, these requirements are based on the National Electrical Code (NEC). (Canadians use the Canadian Electrical Code, or CEC.) The NEC carries no enforcement power and is written as an advisory document only, but for all intents and purposes, this is the main set of rules on which local codes are based.

The NEC is the guiding authority for electricians and is not exactly bedtime reading for the rest of us. Local codes might be more stringent in some areas. As a homeowner or an electrician, you have to be aware of any specific rules that your local codes might impose.

Electrical codes spell out, among other things ...

- Lighting requirements
- Receptacles needed per square foot of living space
- How the system should be grounded
- Circuit sizes
- Required wire gauge or size per individual circuit
- Special stipulations for kitchens, bathrooms, hot tubs, pools, fountains, and outdoors

Codes are like personal relationships: Everything can be going along just fine until there's a misunderstanding or a misinterpretation of something someone has said. Then all interested parties have a problem. Electrical inspectors and electricians, both professional and do-it-yourselfers, sometimes have different interpretations of the code. For this reason, you want to be absolutely sure your work is done in the most straightforward manner possible, even if it means a little more expense or work on your part. After all, regardless of your interpretation, it's the inspector who makes the final ruling. The authority having jurisdiction of the code will have the responsibility for making interpretations of the rules (Article 90-4). Leave literary license to wayward authors.



Positively Shocking

The National Electrical Code (NEC) is designed strictly as a safety measure to protect you and your property. It is not meant to be an instruction manual for amateur electricians or to be used as a design specification for your home or business. The NEC covers most, but not all, electrical installations.

Safety Rules, Mr./Ms. Homeowner

It has been suggested that early electricians at the turn of the century were a paranoid lot. This was a new, untested medium that was replacing familiar gas lighting. These

electricians weren't interested in developing reputations as de facto arsonists. Wiring at the time was pretty simple to begin with, usually just lighting circuits, one receptacle per average-size room, and a very small service or fuse box. Electricians used lead solder followed by tape to join wires and do their work safely.

Your dealings with electricity should be equally safe, whether you're installing a new circuit or screwing in a light bulb. Electricity always is seeking an easy way to travel. Sticking your fingers, screwdrivers, or car keys into light sockets or receptacles provides these charged particles with an alternative path to moving along a wire. An improperly grounded toaster can cook more than your bagels. We'll cover the basic safety rules in Chapter 7, "Caution Signs and Safety Concerns." For now, you'll need to keep a few rules in mind when dealing with your electrical system:

- Don't handle anything electrical if you're wet or are standing on a wet surface.
- Never overload a circuit beyond its capacity.
- Extension cords are for temporary use only.
- Never start an electrical repair or addition until you're sure how to do the job correctly and the power is shut off.
- When a problem is beyond your expertise, call a licensed electrician.

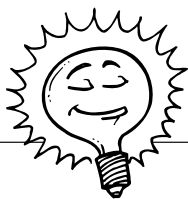

Bright Idea

If you have to change a fuse or check a circuit breaker in an area where the floor might be damp, lay down a piece of plywood first. Standing on this will keep you on dry ground, which is less hazardous than damp concrete. You also should wear dry, rubber-soled shoes and leave one hand in your pocket to keep from inadvertently becoming a pathway for the electrical current.

Mutual Respect

Franklin D. Roosevelt said that the only thing we have to fear is fear itself. He obviously never dealt with the IRS. We can include electricity as one thing we don't have to fear, but we do need to respect it. You and your electrical system will get along just fine as long as you don't demand more of it than it's designed to provide. Most problems with electricity result from poor workmanship, code violations, and user abuse. Old systems were designed to power far fewer toys and gadgets than we have today. Trying to run three or four small kitchen appliances out of one receptacle, rather than running a new circuit, is just asking for trouble.

Do It Yourself or Hire It Out?

Electricians are one of the elite—and expensive—building trades. They are trained and tested to become licensed (a must when you're hiring). They most likely can do a large job faster than you can. As with any

trade, *electricians* come equipped with the tools and knowledge that you are now just beginning to acquire. This doesn't mean you aren't up to the challenge—for most jobs, you will be. Once you understand how to run new circuits, replace lights, and upgrade old wiring, you'll be able to do your own electrical work in a professional manner.

In addition to having a working knowledge of the code requirements and knowing how to install your wiring and fixtures, just what does this work involve? The following sections explain this in more detail.

Drilling and Pulling

The physical act of wiring is largely a matter of getting power from point A to point B in a manner approved by the code. Point A might be your main service panel (where the power enters your house), or it might be a receptacle on an adjoining wall. Either way, you have to figure out the best route to run your wire so A and B can be connected.

How do you define the best way? That depends on your circumstances:

- Are your walls and ceilings open with the studs and joist exposed?
- Do you have to work around old plaster and lath or newer drywall?
- Is there basement, attic, or crawl-space access?

Much of an electrician's time is spent drilling holes in wall studs and floor joist and pulling electrical cable from one fixture or receptacle to another. This work is tougher in a finished house, especially one with old plaster walls or limited access from either a basement or attic crawl space. This is time-consuming work, and its cost can be difficult to estimate. In my opinion, these are perfect jobs for homeowners who can take their time drilling and "fishing" wires even if they don't want to do the final connections or fixture installations. A couple of weekends or evenings with a commercial-quality drill and a roll of electrical cable can greatly reduce the time an electrician spends in your house—and can greatly reduce your costs.



Ask an Electrician

In terms of training and expertise, an **electrician** starts out as an **apprentice** before moving up to **certified journeyman** status. With additional training and testing, he or she can become a **master electrician**.

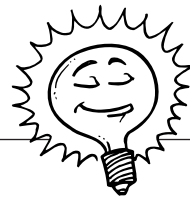

Bright Idea

It's always easier to have two people feeding and pulling wires between floors, even if you can do the work alone. Kids can get in on the work, too. This gives them a sense of accomplishment as well as some basic knowledge of how wiring works. This is a great skill to have when they're older and are wiring their own homes.

Neatness Counts

I cannot emphasize enough the need for clean, neat, and accurate work when doing your own electrical jobs. Inspectors aren't fond of homeowners doing their own wiring, and they probably will scrutinize your work more than the work of an electrician. Chalk it up to one more example of life being unfair, or see it as motivation to do the best work possible. (How's that for making lemonade out of lemons?)

A new electrical service that's been done well is a beautiful exercise in symmetry. All the wires entering the service panel are installed at neat right angles without any excess length. Wires running along exposed basement floor joist are taut, stapled, and secured. The point of the staple is to gently hold the cable in place. It is very easy to damage the outer sheath of NMB (nonmetallic) cable if you aggressively pound staples against it.

Cable inside receptacle and switch boxes is cut clean and is folded in and out of the way at the back of the boxes. These are not inordinate standards but the ones an inspector expects to see. You should expect them, too, whether you do your own work or hire it out.

Can you get these results as a novice? Of course you can! It will take you longer than a trained electrician, but so would just about any work that's new to you. That's why you bought this book. This text—and a few good tools (see Chapter 8, "Call Me Sparky")—will see you through most electrical jobs with inspector-pleasing results.



Electrical Elaboration

A good electrical inspector will work with you on a project and will inform you of possible missteps that might be in the making. On my first commercial job, the inspector didn't say a word to the electrician about the way he was routing his cable between floors until the job was almost finished. At that point, she told him it wasn't correct and would have to be redone. They disagreed about how to interpret the code, but nevertheless, she should have brought up her concerns earlier. He didn't have to reroute, but he did have to change some panel boxes, which could have been avoided had they both communicated more clearly.

Simple Projects First

Before you go yanking your old fuse box out, convinced that you can replace it before dinnertime with new circuit breakers, look for a small job to do first. Most older homes have at least one receptacle or switch that needs replacing. There are other jobs to consider as well such as ...

- Adding extra garage lights.
- Running a dedicated circuit for your office computer.
- Installing a bathroom fan.
- Adding lights to your backyard.

These are good jobs for practicing your evolving electrical skills without causing too much disruption around your house. They all involve applying for a *permit*, scheduling an inspection, calculating an electrical load, running wire from a power source to a fixture, installing the fixture, and making the final connections of wire, fixture, and power source. Each of these jobs is a microcosm of a larger project such as re-wiring your entire house, and each is a good confidence booster. You can even take snapshots of your work to carry around in your wallet, but be prepared for some strange looks from your friends when you pull them out for showing.

System Checkup

By now, you're probably getting some ideas for the kinds of projects you might consider doing, but what do you really need to do? What shape is your electrical system in now? The newer the house, the more likely there is less code work to do. That is, you shouldn't have to correct any existing wiring if it's original to the house. This isn't an absolute rule, however! Sometimes an inspector misses something or an owner does some work that isn't up to code.

Older houses are more problematic. It's common to find a jumble of add-ons and questionable work in an old home. Even a cursory inspection will give you some idea of electrical improvements you might consider making.

Plugless in Seattle

One of the biggest drawbacks to old wiring systems is a lack of receptacles or outlets. Remember, our parents' and grandparents' generations had far fewer voltage-eating consumer trinkets and entertainment devices than we have today. Current code calls for ...



Ask an Electrician

Any work that extends an existing electrical system by adding a circuit or a fixture usually requires a **permit** and an inspection. Any work that simply replaces an existing fixture, such as a light or a receptacle, usually doesn't. Always check with your local building department to be sure.

- A receptacle to be installed so a six-foot cord can be plugged in anywhere along a wall in general living areas.
- Special ground-fault circuit interrupter (GFCI) outlets to be installed in kitchens, bathrooms, near any sinks, and outdoors.
- Special considerations for floor-mounted outlets.

Could you use some additional receptacles? Is your bathroom receptacle up to code with a GFCI? Look around your house to see if you could use some additional receptacles. Also make sure your bathroom receptacle has a GFCI, as code requires.

Let There Be Light

Parents and teachers of a certain generation regularly reprimanded children to do their reading in “decent” light, warning that they could “ruin” their eyes by using dim lights. Whether you believe this to be a medical fact or not (I’ve heard it both ways), why not give yourself as much light as possible when you read or do other close work? Adding lighting where you want it is one of the great benefits of electrical wiring.



Positively Shocking

When replacing lights, don’t assume you can install a light with higher wattage. The circuit might not support the additional power demand. You always should confirm the total demand by other lights, receptacles, or appliances before changing an existing fixture.

Lighting fulfills other purposes besides purely practical ones. It can set a mood, spark romance, and ward off ne’er-do-wells lurking outside on a dark night. Yard lights invite summertime parties and welcome us home in the winter. Adding additional lighting is a more complicated job than simply adding a receptacle, but it certainly is within the scope for a homeowner to do.

Hot Spots

Any receptacle or switch that is hot to the touch is an overloaded circuit. This is a circuit that is drawing more current than it’s designed to draw. If you have any hot spots, you must attend to them immediately. (You can start by pulling a few plugs or turning off the lights.) A shortage of receptacles or lights is an inconvenience; an overloaded circuit is a danger that should not be ignored.

Special Needs

Every home and homeowner is different. What might have been a perfectly acceptable electrical system for a previous owner might be woefully deficient for you. Maybe you want to install a small baseboard heater in a bathroom located a long way from the furnace. Your photography hobby might demand a darkroom. As an antique car restorer, you can’t wait to set up a paint booth in the garage complete with industrial heating units for that baked-on finish guaranteed to win a trophy or two.

New houses often are constructed with the minimum number of code-required receptacles and lighting. Exceptions are made with kitchen and bathroom lights; these are high-profile areas that help sell houses, so builders make them brighter and more appealing with better lighting. Old houses often have a real hodgepodge of wiring that you'll probably want to upgrade and expand. One of the reasons you're reading this book is to custom design and improve your electrical system to suit your needs, not those of a builder or a previous owner.

Confused About Fuses?

Every fully electrified house has either a fuse box or a main panel box with circuit breakers. This is the distribution center for the power coming into your house. Without them, you would have one whopping current running through your walls that would burn out just about any appliance you tried to run on it.

Fuses were used until approximately 1950, when circuit breakers became the standard installation for new construction. The fuses most of us are familiar with are the round, screw-in glass types with a visible alloy strip inside the glass. These are called plug fuses. Cartridge fuses, which have a cylindrical shape, are the other common type of fuse.

If the current running across a plug fuse's alloy strip exceeds the amperage of the fuse, the strip will melt, thus stopping the flow of electricity. There is nothing inherently wrong with a system using fuses, but they are dated and inconvenient. If you don't have any spares around when one "blows"—you should always replace a fuse with one of the same amperage—you're out of luck. The other problem with plug fuses is that a fuse with an amperage setting of 15, 20, 25, or 30 can be installed as a replacement for a burnt-out fuse even if the original size should have been 15 amps. Even though it is physically possible to install the wrong fuse, doing so could overload a circuit and might even start a fire in your home. To prevent this, the installation of an "S" type adapter will limit the maximum fuse size to 20 amps.

Circuit breakers, the modern standard for homes, are an improvement over fuses, as you'll see in the next section.

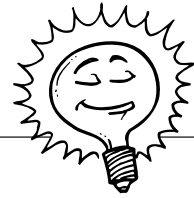

Bright Idea

If you're uncomfortable putting your hand into a fuse box to replace a burned-out fuse, you can buy a tool to help with the job. Electrical-supply companies sell plastic fuse pullers specifically made for gripping fuses and removing them. The plastic will not conduct electricity, so there's no danger of receiving a shock through them.



Electrical Elaboration

Although circuit breakers are the standard equipment for circuit protection in your home, fuses are still used in many other applications. Fuses with ratings as high as 10,000 amps and 136,000 volts are used in marine, automotive, telecommunications, and computer applications. Fuses provide circuit protection in motors, transformers, and an array of delicate electronic equipment.

Circuit Breakers

A circuit breaker serves the same function as a fuse, but it's a more complicated device. It also is reusable. When a current that exceeds the breaker's capacity or rating passes through it, a pair of metal contacts is broken and remain so until the breaker is reset. A breaker can be reset an almost indefinite number of times, although repeated tripping is a sign of an electrical problem or overload. Any time a breaker trips or a fuse burns out, you must find the source of the problem before you reset the breaker or replace the fuse. Sometimes it's only a single-occurrence problem such as running too many appliances at once. If you can't find an apparent cause in your use of the circuit, you probably have a short in the system that must be addressed (see Chapter 16, "Trouble, Troubleshooting, and Safety").

More Power to the People

Modern electrical systems give us access to plenty of safe, dependable power. Around the turn of the century, it was a big deal to have a 60-amp service. Now, 200-amp services are common in many houses, and some larger homes are even getting 400 amps of power. We are dependent on electricity for our safety and well-being. One purpose of this book is to help you put it to the best use possible in your home.

Any electrical system can be improved and adapted to your individual needs and specifications:

- A larger service of greater amperage can be installed.
- New circuits can be added.
- Existing circuits sometimes can be extended.

- Lights can be added anywhere there is a need for them.
- Additional wiring can facilitate modern contrivances from garage door openers to barbecue rotisseries.

As you read on, you'll learn how to perform these electrical chores by yourself or how to evaluate your needs and discuss them intelligently with an electrician. Either way, you'll have power at your fingertips throughout your home.

The Least You Need to Know

- Electrical systems are logical, precise, and guided by local electrical codes.
- A do-it-yourselfer can safely do many electrical projects around the house, but he or she should start with simple jobs first.
- A simple walk-through of your house and yard will give you some improvement and upgrade ideas for your electrical system.
- Take the time to design your electrical system or upgrades to suit your needs, lifestyle, and sense of convenience.



What Is Electricity Anyway?

In This Chapter

- ▶ How alternating current works
- ▶ Staying grounded for safety
- ▶ Knowing volts, watts, and amps
- ▶ Wire size matters

We use and depend on electricity every single day. All we usually know about it is that it's buried inside our walls, it runs our lights and VCRs, and we're billed for it every month or so. Terms such as kilowatt hours, amperage, volts, and current are Greek to most of us. This is probably appropriate because the Greeks first described static electricity about 2,500 years ago. It was discovered that amber would accumulate a negative charge of static electricity when rubbed with sheep's wool. Not known for a great sense of comedy, this probably became quite the party trick at Greek get-togethers. The word "electricity" has its root in the term *electrum*, which is Latin for "amber."

Understanding electricity is like understanding cooking: Once you know a bit about sautéing, cooking temperatures, seasonings, and how to make a decent pie crust, you can muddle through meal preparation and come up with more-than-edible results. If you know how electricity is produced and can toss around some vocabulary words, such as alternating current and resistance, you'll be more comfortable with your electrical work. A task makes more sense when you understand its inner workings.

This chapter isn't going to give you enough information to challenge a Ph.D. in electrical engineering to a trivia contest at your local *Jeopardy* theme bar. You will, however, develop a working knowledge of electricity basics and how they apply to your own electrical system.



Ask an Electrician

Electricity is the movement of electrons. A **conductor** holds its own electrons loosely, so current can easily pass through. Metals, such as copper wire, are good conductors for carrying electric current. An **insulator** has tightly held electrons, which means current does not flow through it. Plastic, used to wrap around copper wire, is a good insulator, as is cloth, which was once used for the same purpose.

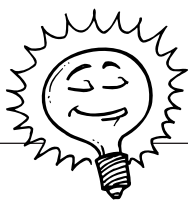

Bright Idea

You can make your own inexpensive anti-static spray by combining 1 teaspoon of liquid fabric softener with 1 quart of water in a spray bottle. Lightly spray your carpet and renew as needed.

Go with the Flow

Think back to your high school physics classes and all those diagrams of atoms with electrons spinning around a nucleus. (They're the drawings that looked like really small solar systems.) Basically, electrons spin around because the protons in the atom's nucleus carry a positive charge (+) that repels the electrons' negative charge (-). If enough of the electrons decide to move on, preferably in a more or less uniform stream, we end up with usable electricity.

Electricity comes in several flavors, but the two we're most familiar with are ...

- Static electricity, in which the electric charges are stationary.
- Dynamic electricity, in which the electric charges are moving in a current.

When you were younger, the main value of static electricity was using it to shock unsuspecting siblings and cousins after you had walked across a carpet. If you didn't do this when you were a kid, you can always try it at your next holiday dinner. Cats also are good targets, but their revenge usually is a messier affair.

Why does the shock occur? Because some electrons like to travel, and they aren't the most stable subatomic particles. When you walk across a carpet (some are worse than others), you pick up some of these hitchhiking electrons while leaving some of your own positive charges. They have to go somewhere, and your sibling's finger or a doorknob makes a dandy conductor. If you touch a door frame, nothing happens because wood is a good insulator. That is, it does not allow electrons to easily move through it.

Static electricity is simply an imbalance of positive and negative charges. When you get zapped, you're just the accountant trying to balance these charges. One place you don't want to balance these charges, by the way, is with your computer, so you can either ...

- Touch your metal desk chair before turning on your computer to get rid of any pesky electrons that could affect your computer.
- Apply anti-static spray periodically to your carpet so it will have a more positive charge and be less likely to give up its electrons.

Static electricity may be annoying, but dynamic electricity is another story altogether.

Staying Current

Electricity doesn't do us much good if a bunch of errant electrons constantly change orchestras from one conductor to another. We want our electrons to move in a reasonably orderly fashion so they can do our bidding when we turn on the lights. A flow of electricity is called a current, and it's carried into our homes through wiring from local electric utility companies. New electrical systems have the following three wires coming into your house:

- Two black or "hot" wires that carry the current to your service panel
- One bare neutral wire for carrying the current back to the power source and to ground

An electrical current has a couple of different options, depending on your application.

AC/DC

When Thomas Edison and his crew invented a reliable electric light bulb, he followed it up by developing the power systems to run it, rightfully envisioning a future world full of light bulbs. (We usually refer to these as "light bulbs," but "lamps" actually is the correct term. Bulbs are for planting.) Edison employed direct current (DC), which now is used in battery-operated gadgets in which the current flows from the negative terminal of the battery to the positive terminal. A battery is basically a container of chemicals whose electrochemical reactions produce excess electrons.

Our electrical systems use alternating current (AC), which was developed by Edison's contemporary, George Westinghouse, after he bought up patents from Nikola Tesla and William Stanley. Once again, someone with business sense trumped the scientific minds possessing the money-making ideas. It took Edison, the lampmeister, a few years to go along with this AC business, but he eventually told Westinghouse's son to let his dad know he was right.

A direct current just means that the electric current flows continuously in one direction and keeps going until it finds something to run such as a radio or a light bulb. An alternating current flows in one direction—say, to a receptacle—and then flows back in the opposite direction. You might be thinking, so what? When was the last time alternating current was discussed on late-night talk shows? Probably never. Alternating current, however, does have some useful, consumer-friendly features such as the following:

- Through a series of transformers, an AC can be increased or decreased in value. (The current can be made stronger or weaker.) This means that, instead of a zillion watts of power heading for your panel box, you'll get a reduced amount that you actually can use.
- Alternating current is efficiently transported over long-distance power lines.
- It's easy to convert from AC to DC, but it's expensive to go from DC to AC.

Electricity—from your utility to you.

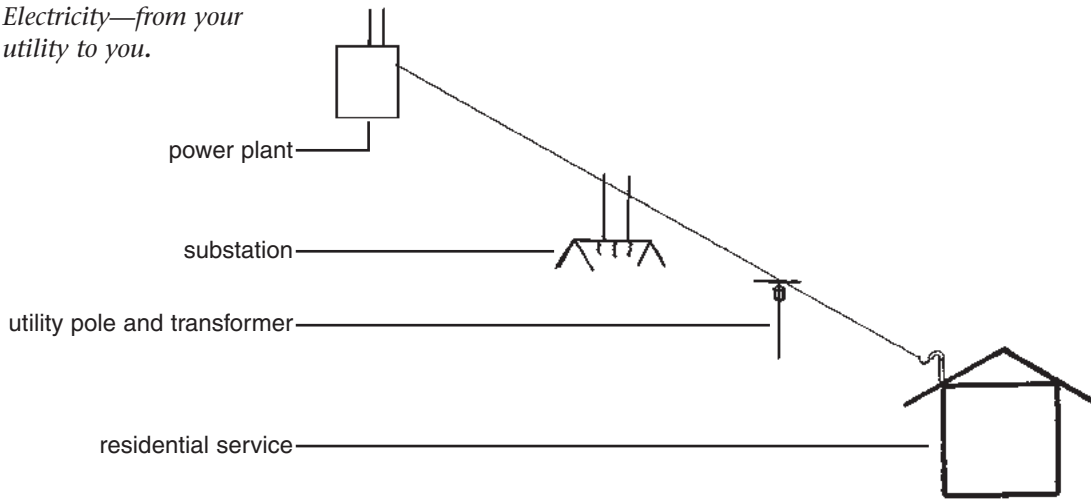

Electrical Elaboration

George Westinghouse installed the world's first long-distance AC power lines in the unlikely area of the San Juan Mountains near Telluride, Colorado. Rapid expansion of gold mining had exhausted nearby timber supplies, the cheap fuel that ran the steam-powered machines the mines required. L. L. Nunn, a partner in the Gold King Mine, traveled to Pittsburgh and convinced a reluctant Westinghouse to build a generator and motor in the isolated mountain region despite its freezing temperatures and avalanche dangers. Nunn threw the switch on June 21, 1891, beginning a new era in electric power in the United States.

You're Grounded

Now that you know what kind of current you have in your house (and everywhere else), let's discuss another critical feature—grounding. Your entire electrical system, if it's up to current code, is grounded for your protection. This literally means that one wire of your electrical system leads back into the earth itself, where it will carry any errant current that could otherwise shock or electrocute you.

The earth ends up being a good electrical conductor and a convenient return path for electrons. In fact, the earth is used as a reference point for measuring the voltage in our electrical systems.

A ground wire can be attached to a ground rod that is deeply buried, or it can be a length of copper wire buried near your foundation's footings. A second physical ground is usually your cold-water supply pipe near your service panel.

Modern house wiring is color-coded so you won't confuse your hot, neutral, and ground wires with one another. This coding is standard everywhere—there is no room for artistic creativity here. The wire colors are ...

- Black and red for hot wires
- White for neutral wires
- Bare (unsheathed) copper or green for ground wires

The black, red, white, and green colors refer to the plastic sheathing that contains the wires themselves. If you have an old two-wire system (see Chapter 5, "More Wall Talk"), you won't have a ground wire. An old knob-and-tube system (see Chapter 3, "History Lessons") sheaths both the hot and neutral wires in black, which isn't exactly user-friendly when you're trying to distinguish one wire from another.

It's important to understand the difference between the grounding wire and the neutral wire. The neutral white wire carries the electrical current back to the power source after it's passed through a *load* (a ceiling light, a fan, a stereo, and so on). That's the nature of an alternating current. The grounding wire, on the other hand, protects the entire system. The neutral wire is more correctly referred to as a *grounded conductor*. The bare or copper wire is a *grounding conductor*.

Voltage Provides the Push

There are a lot of terms associated with electricity. Different words refer to a current's strength, the speed at which it travels, and the rate at which it's consumed. *Voltage* is a sometimes-misunderstood term that means "electromotive force" or, more simply, electrical "pressure." Voltage also is the difference in electrical potential between one end of a circuit and the other. In our electrical systems, voltage is measured against the earth, which is at zero potential. In other words, it all starts with the ground under your feet. Voltage gets the electrical ball rolling by giving a push to electric power from your utility's generator to your house or business.



Ask an Electrician

The term **load** refers to any device that uses electricity. Your house is basically one large cumulative load, and lights, appliances, and air conditioning are individual loads.

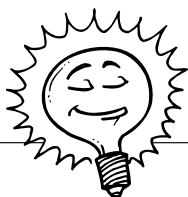

Bright Idea

If you're working with electricity or with electrical tools outside your house, you can't avoid some contact with the ground. You can minimize any shocks by using a wood or fiberglass ladder. (Note: Electricians aren't allowed to use metal ladders.) Wearing boots or shoes with thick rubber soles also will provide insulation between you and the ground.



Positively Shocking

Europe and other parts of the world use a 220/240-volt electrical system. Before you can plug in your notebook PC, razor, or hair dryer, you have to use a converter to reduce the current to 120V. Converters are available at travel specialty stores and many overseas hotels.

Long-distance power lines carry huge voltages, from around 155,000 to 765,000 volts. If you hooked your vacuum cleaner up to that kind of power, you'd melt its engine instantly—and possibly yourself as well. You previously read that transformers reduce the voltage before it enters your house. A few hundred thousand volts might sound like fun to your kids, but you should be grateful that you end up with a lot less voltage, thanks to transformers.

Know Your Volts: 120/240

Your utility company supplies your home with a split-phase 240-volt feed. This means that the two hot wires coming into your service panel are each carrying 120 volts. This provides power for major appliances such as electric stoves and clothes dryers that require both 240 volts and 120 volts. Just about everything else in your house only requires 120 volts.

Because of voltage drops in your house wiring, these numbers might drop as low as 220V and 110V. Some appliances and other electrical items even indicate on their instructions that they are rated at 220V or 110V. This is the manufacturers' way of telling you that their products will still work correctly when the voltage drops. An electrician or builder might refer to a 220/110 system, but it's really 240/120. This is an important concept. Reread this paragraph if you find it confusing.

Amps for Short

Volts measure the force of an electrical current, which is the movement of zillions of electrons. *Amperes* or *amps* measure the number of electrons in a current moving past a specific point on a wire or another conductor in a one-second period of time. If you want an exact number, one ampere equals one coulomb of electrical charge moving across a conductor in one second (or 6,250,000,000,000,000 electrons per second).

Coulombs were named for that fun eighteenth-century French physicist, Charles A. de Coulomb. If electricity were water, volts would be the speed of the water, and amps would be the amount of water flowing through your hose.

A new three- or four-bedroom house often will have a 200-amp service; apartments or small condominiums might only need 100-amp services. Individual fuses and circuit breakers are measured in amperes. That is, they only allow a certain amount of current to pass through before they shut down the current.

Watt's That?

Watts are one of the measurements you will refer to in your electrical work. Most of us know the term from buying light bulbs (I know, the term should be lamps, but this isn't an easy one to get away from) as in "Why do we have a shelf full of 60-watt bulbs when I need 100?" A *watt* is a unit of electrical power. It tells you how much electricity you're consuming and being billed for by your utility company. This is why you have a meter outside your house recording your usage.

A single watt is a minuscule way to measure power usage, so the following larger units of measure are used instead:

- Kilowatt or kw (1 kw = 1,000 watts)
- Megawatt (1 megawatt = 1,000 kw or 1 million watts)

You've really got some usage problems if your electric bill indicates that you're in the megawatt range. (Perhaps you have a refrigerated warehouse on your roof.)

Wattage Around the House

How do watts figure into your electrical calculations? It's simple: They tell you how much stuff you can pile onto one circuit without overloading it. You don't want to put too much demand on a circuit with too many watt-hungry loads. Some simple math will keep you on the right track.

Watts equal voltage times amps. Let's say you want to install a new 15-amp circuit so you can add some outlets or lights to your living room and dining room. Because you won't be running any major appliances (assuming you don't do your laundry in the living room), this circuit will be running on 120 volts rather than 240. Therefore ...

$$120V \times 15A = 1,800 \text{ watts}$$

Terrific, you say. I can put in 18 100-watt lights. Actually, you can't, because you generally figure on running only 80 percent of the maximum load



Ask an Electrician

The **meter** associated with your electrical system is more correctly known as a **kilowatt-hour meter**. Your electric bill is calculated in kilowatt-hours (KWH). Each kilowatt-hour equals 1,000 watts of energy used for one hour. A 40-watt light bulb would have to burn 25 hours to equal 1 KWH.

(see Chapter 5)—1,440 watts in this case—but that’s still 14 lights with watts to spare. What if you want to plug in your new window-shattering, guaranteed-to-have-the-neighbors-call-the-police music system that needs 1,900 watts all by itself? Time to recalculate. It’s going to need its own private 20-amp circuit before you can crank up Eric Clapton’s original version of “Layla.” By calculating your electrical needs first, you can accurately wire your house once without needing to make adjustments later.



Electrical Elaboration

Large appliances are on 240V lines because their power demands are so much greater than small items such as lights or clock radios. An electric range, for example, can demand more than 12,000 watts, and an electric dryer can draw close to 5,000 watts. Other major appliances such as refrigerators and washing machines only require a 120V line. They usually are assigned a separate circuit.

This Joule Isn't a Gemstone

Another oddball measurement you might run into if you buy, for example, a surge suppressor for your computer equipment is a *joule*. Named after James Joule, all-around smart guy and the son of a nineteenth-century English brewer, a joule in the field of electricity is the amount of energy equal to 1 watt acting for one second. When it comes to surge suppressors, the more joules of protection, the better.

Resistance Isn't Futile

Everywhere we look in life, we find some form of resistance. For airplanes, it shows up in the form of wind (and maybe an occasional bird or two). Water keeps kayakers afloat, but it also slows them down some. Even the indomitable James Bond in his Aston Martin DB5 had to contend with resistance when his tires hit the road.

It would be great if all the electrons in a current could go gliding across a copper wire (or another conductor) free and clear, but pesky resistance prevents them from doing so. Resistance in a conductor opposes the flow of an electric current. This results in some of the electrical energy changing to heat, which you want to minimize. Hot wires can be dangerous wires. On the other hand, resistance is built into the system to control the strength of the current running through it. You also don't want your blender getting hit with 50 amps of electricity when you're mixing a fruit shake.

Electrically speaking, resistance is measured in *ohms*. Ohm's Law (Ohm was a German physicist with a great name) basically says that the smaller the wire or conductor, the greater the resistance to a current. If you crank up the amps, you get even more resistance, sometimes to the point of overheating and causing a fire. Loads that require more amps also require larger wire to handle the current flow. If you increase the size of the wire, the resistance goes down, and you get a weaker current with less voltage drop. This is one of the reasons you have several different sizes of wire in your house.

Think of it this way: Imagine that the fire department is putting out a fire in your house. You're happy that they're using a big hose (just as a No.6 or No.10 is a big wire for big jobs). But what if you're just watering your garden? Then you want to conserve water and avoid flooding the garden. You'll use a small hose (just as a No.12 or No.14 wire is good for small items such as light fixtures).

All Wire Isn't Created Equal

Other than a brief foray in the 1970s when aluminum wiring was popular, copper is king when it comes to house wiring. Copper rates high on the conductivity scale. That is, it's an efficient pathway for an electrical current.



Ask an Electrician

The diameter of a wire is measured in **mils** or, more accurately, **circular mils (CM)**. A mil equals $\frac{1}{1,000}$ of an inch. Wire is assigned a **gauge value** by the American Wire Gauge (AWG) rating. The lower the number, the thicker the wire. No.8 gauge wire, for example, is thicker than No.14 gauge wire.

Conductivity Scale

Material	Percentage
Silver	100%
Copper	98%
Aluminum	61%
Iron	16%
Nickel	7%

In addition to a wire's conductivity, its size and the type of insulation around the wire affect its *ampacity*, or the amount of current (in amps) it can carry before it exceeds its temperature rating. The greater its size, as measured in *mils*, the more current it can conduct.

Every wire size has a maximum current that it can conduct. The following table shows the most common residential wire sizes and their ratings.

Wire Gauge Rating

Gauge Value	Ampacity
14	15 amps
12	20 amps
10	30 amps
8	40 amps
6	55 amps

Appliance and lamp cords use No.16 or No.18 wire, which is quite thin. This might lead you to ask, “Well, if thinner wire has a lot of resistance and can heat up easily, but thicker wire can hold more juice without overheating, why don’t we use thicker wire throughout our homes? Wouldn’t that be safer?” This is a reasonable question, and it has two answers: flexibility and cost.

Modern NMB cable, black or hot conductor; white or neutral conductor; grounding conductor; plastic insulation.

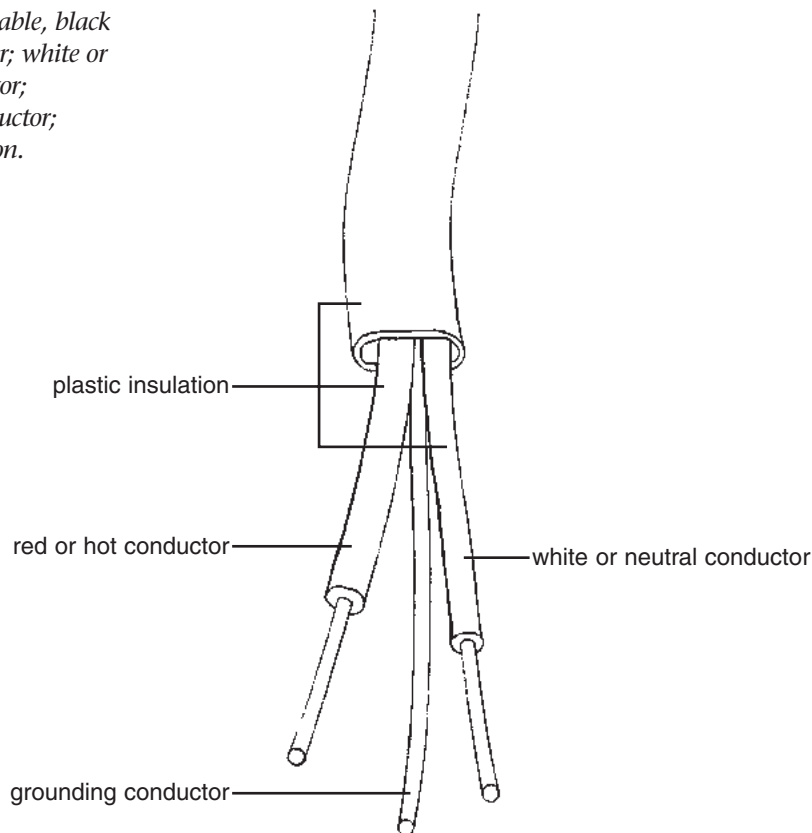

If you try to bend and fit No.8 wire so you can connect it to a light fixture, you'll come to appreciate the flexibility of smaller wire. Like just about anything else in life, the larger the size, the greater the cost. There's a reason home-improvement stores periodically have loss-leader sales on No.12 wire but not any of the thicker stuff.

Other factors that affect your choice of wire will be discussed in later chapters.

No Substituting

The society of wire and conductors is a very closed one. No amount of politically correct persuasion will convince one gauge of wire to mingle with another. You should not mix No.12 wire with No.14 on the same circuit, for example. Wire must match up with its circuit breakers or fuses; No.14 wire doesn't go with a 20-amp breaker, so don't confuse either party by mixing them together. You *can* install larger wire on a smaller circuit breaker, but you cannot install a smaller wire on a larger circuit breaker.

The Least You Need to Know

- Electricity is a flow of electrons that, when in the form of an alternating current, can be used to power our homes.
- All modern electrical systems are grounded for safety.
- Volts, amps, and watts are common measurements of electricity.
- There are several fixed wire sizes. Each size of wire is designed to carry a specific amount of amps. Don't mix them up.



History Lessons

In This Chapter

- ▶ The people who brought us electricity
- ▶ Safety—always an issue
- ▶ Evolving standards
- ▶ Knob-and-tube wiring
- ▶ Demanding more power

Many people think of the era of electricity as beginning with Thomas Edison and his electric lamp (or light bulb). His work was crucial in popularizing electricity and in making it practical for modern life, but a long list of scientists preceded Edison in this field. It took centuries of work just to discover what electricity is. I already mentioned the Greeks and their party tricks—creating static electricity by rubbing a piece of amber with wool or fur. They became pretty busy creating democracy as well as feta cheese, so they didn't get any further with electricity.

A couple *thousand* years later, around the year 1600, English scientist William Gilbert got the ball rolling again when he coined the term “electric” while describing the theory of magnetism. He was followed by a host of physicists, most of whom had laws, theories, or measurements named after them. These scientists laid the groundwork for industrialists like Edison and Westinghouse, who were able to exploit electricity and get it out of the laboratory.

Once the light bulbs started glowing, electricity became the computer industry of its day, with constant innovations, the building of an infrastructure, and a steady array of new uses. The dreams of merchandisers were realized in the years to follow, as they convinced the world to buy new gadgets and products that everyone previously had lived without, apparently in blissful ignorance. Electric lamps were followed by early versions of curling irons, electric cars, and waffle irons. Today, even Edison would be amazed at the electric world he helped create.

An International Effort

The development and nurturing of electrical power resulted from the work of scientists and accidental discoveries on both sides of the Atlantic Ocean. This essentially was a European and American deal, and it included contributions from England, Scotland, France, Yugoslavia, Germany, and Italy. The earliest attempts to create or reproduce electrical currents were through the use of crude batteries. The Energizer Bunny wouldn't have completed one drumbeat powered by these early batteries.



Positively Shocking

If you're ever playing a trivia game and are asked who invented the first electric light bulb (lamp), do not answer Thomas Edison! Sir Humphry Davy (1778–1829) conducted the earliest experiments in electric lighting, and the first incandescent bulbs were patented in 1840. Thomas Swan, another British inventor, was working on a carbon-filament lamp at the same time as Edison.

For the most part, these early physicists (they almost all were physicists) studied electrical phenomena, quantifying their observations so each one could conclude, "A-ha! It really hurts when you stand in a metal bucket of water and touch the bare ends of hot wires together!" Each contributor added to a gradually developing body of knowledge about electricity.

The Pioneers

A number of key players were poking and probing into electricity, most of them during the eighteenth and nineteenth centuries. Considering the unsophisticated equipment these scientists used, their accomplishments are that much more remarkable. It's not like they could refer to a textbook—they were writing the textbooks! You'll recognize some of these scientists as the namesakes of some electrical terms we use today.

Ben Franklin Flies a Kite

Ben Franklin, the colonial printer known for pithy quotes who is now pictured on \$100 bills, is famous for having flown a kite during a lightning storm—a practice not advocated by this author or your local hospital. Franklin was testing his idea that lightning was a form of electrical current. A metal key attached to the kite attracted the lightning as its electrical charge traveled down the kite's cord and into Franklin's wrist. As a result of his

1752 kite-flying and his follow-up observations, Franklin developed the terms “conductor,” “charge,” “electrician,” and not surprisingly, “electric shock.”

Galvani’s Frog Legs

Luigi Galvani had the perfect name for an East Coast Italian restaurant, but his only known association with gourmet food was his famous experiment with frog legs in 1786. The professor of medicine in Bologna accidentally produced an electric charge against the legs of a dead frog. The charge was the result of the wet frog lying on a metal plate while being probed with a knife made from a different metal. Galvani was convinced that the twitching legs were the result of electricity already existing in the frog’s tissues and muscles. He was none too pleased when his friend Alessandro Volta disagreed and proved him wrong by showing that moisture caught between two different metals can create a small current, frog or no frog.

As a result of his disputatious observations, Volta went on to invent the first electric battery (called the voltaic pile) and, more important, to show that electricity could flow in a current along a wire instead of only in a single spark or shock.

In addition to being named a count in 1801 by Napoleon, Volta had the term “volt” named after him. As for Dr. Frog Legs, he walked away with the consolation prize of having the term “galvanism” (to have an electric current) named after him.

Watt

James Watt was an engineer at the University of Glasgow. He was a steam-engine guy who invented the steam-condensing engine and subsequent improvements in the 1700s. Watt was probably very motivated to work with steam: Scotland is cold in the winter, even with today’s central heating. It must have felt like Antarctica back in the eighteenth century.

Edison coupled his own generator with Watt’s steam engine to produce the first large-scale electricity generation. As you can guess, the term “watt,” a unit of power, was named after Watt.

The Amp Man

André Marie Ampère, the first notable French electrophile, researched electricity and magnetism, essentially developing the field of electrodynamics. Not much for

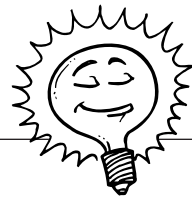

Bright Idea

You can impress your friends and family and probably drive them to vegetarianism at the same time by reproducing Galvani’s discovery in your own kitchen. Instead of using a dead frog, try it with your Thanksgiving turkey right before you stuff it. You might have to cheat and wire it up to a hidden battery, but watch the fun when those legs start moving.

quotable sound bites, Ampère's most important publication, *Memoir on the Mathematical Theory of Electrodynamical Phenomena, Uniquely Deduced from Experience* (1827), is a book only a physicist could love.

A unit of electric current is called an "ampere" in his honor, but Americans, blatant and unapologetic in messing with the French language, call it an "amp" instead.

Oompa-Ohm

In 1827, Georg Simon Ohm, a German physicist and mathematician in Cologne, published *The Galvanic Circuit Investigated Mathematically*, a tome never destined to make the *New York Times* Bestseller list in any category. Lacking acceptance in his native Germany, Ohm eventually was awarded the Copley Medal in 1841 by The Royal Society of Great Britain. Ohm discovered one of the most fundamental laws of electricity: the relationship among resistance, current, and voltage. The resulting law, $V = IR$ (in which V is voltage, I is the current, and R is resistance), gave him a place in the electricity hall of fame. A unit of resistance, the ohm, is named after him.



Electrical Elaboration

Being the first kid on your block with a new law of physics didn't guarantee you stock options or, in the case of Georg Ohm, a pile of deutsche marks. As a university professor, Ohm was severely ridiculed when he tried to mathematically explain his theories of electrical resistance. He left his teaching post and lived for years in poverty before his theories were recognized and accepted. He lived the last years of his life as a full professor at the University of Munich.

Coulomb Was Très Cool

Charles Augustin de Coulomb was an all-around brilliant eighteenth-century French scientist who made major contributions in the areas of physics, civil engineering, and the natural sciences. The unit of electric charge—the coulomb—is named for him. Who could forget "Chuck" Coulomb's 1773 address to the Academy of Science in Paris when he discussed pioneering soil mechanics theory? Coulomb served as "Ingenieur du Roi" ("Engineer of the King") until the French Revolution came calling. He then took a powder and retired to the countryside for a while.

Coulomb is known in the electrical world for verifying the law of attraction or electrostatic force. Basically, he confirmed the notion that opposite charges (+ and -) attract each other and like charges repel. Unlike other observers of this behavior, Coulomb worked the numbers and came up with a nice, neat theory that no one outside the fields of electrical engineering and physics will ever use. Therefore, it's not worth mentioning in any detail in a how-to book, although it would have a real place in *The Complete Idiot's Guide to Physics*.

Other Electrical Fellows

The following European scientists also helped pave the way for the electrical comforts we enjoy today:

- Michael Faraday
- Heinrich Hertz
- Joseph Priestley

Joseph Priestley, in addition to his electrical dabbling, also invented soda water (for which the Coca-Cola Company is eternally grateful).

Michael Faraday is credited with discovering how to generate an electric current on a usable scale. It was known that electricity would create a magnetic field, but Faraday looked at the reverse notion: Why not produce electricity with magnets? In 1831, he discovered that moving a magnet inside a coiled copper wire produces a small electric current. If you spin a large enough magnet really fast inside a larger coil of wire, you'll have yourself a usable electric generator. Faraday's work is the basis for the electrical generators used today.

Now that we've discussed scientists from the Old World the colonists left behind, let's leap over to the American side of the Atlantic, where our usual combination of good timing, enthusiasm, and an attitude of "Hey, this will work, what have we got to lose?" put electricity on the map.

Edison, Mega-Inventor

Thomas Alva Edison was born in Milan, Ohio, on February 11, 1847. According to some stories, he had a whopping three months of formal education, yet he obtained a record 1,093 patents in the United States during his lifetime. Who knows how he



Ask an Electrician

The voltage in an alternating current goes back and forth between zero and maximum as it changes direction along a conductor. It then repeats this cycle 60 times per second, or 60 **hertz (Hz)**, in ordinary house current. This measurement was named for the German physicist Heinrich Hertz.



Positively Shocking

On a more gruesome note, Edison was so adamant about maintaining direct current as the standard for electric power that he used the newly introduced electric chair to point out the dangers of alternating current. His demonstrations showed that a relatively small amount of current (the same current Westinghouse wanted to run inside of homes) could cause death or severe injury, unlike Edison's direct current.



Ask an Electrician

Incandescent refers to heating something until it is red-hot or white-hot and is glowing with heat, thereby giving off light. In a lamp, a filament with high resistance to an electrical current is used. Eventually, after being repeatedly heated to high temperatures, the filament breaks and the lamp needs replacement.

would have done without *any* public schooling! It seems like Edison had his hand in everything: telegraph equipment, movie projectors, phonographs, storage batteries, and most important, electrical lighting.

If Edison were alive today, he'd be spending most of his time in courtrooms defending his far-flung empire from charges of being a monopoly. Compared to Edison, Bill Gates is a piker. The list of Edison's companies and partnerships worldwide goes on for pages and pages. He not only manufactured electric lamps (a.k.a. light bulbs) but also motors, dynamos, phonographs and phonograph records, and telephone equipment. Edison helped form the nascent General Electric Company, one of today's powerhouse corporations, when his Edison General Electric Company merged with the Thomson-Houston Company. Despite his many inventions and businesses, Edison was only financially comfortable. He was nowhere near as wealthy as some of his contemporaries such as Henry Ford.

Let There Be Light

The basics of the construction of the electric lamp (or light bulb, to nonelectricians) were pretty well known by the 1870s. People knew that if you ran electricity down certain substances, the resistance produced light rather than heat. The problem was finding the right filament. Early versions simply didn't last long enough to be useful. The lamp needed a long-lasting filament that would provide pleasing, easy-on-the-eye lighting to be practical.

Edison tested thousands of materials before trying a piece of #70 coarse sewing-machine thread in October 1879. He first baked the thread to carbonize it and extend its life to withstand the heat of an electric current. The rest, as they say, is history. Edison and his assistants scrambled to improve his lamp and to create all the myriad components necessary to get it into peoples' homes. It was Edison's invention of a system to deliver and implement electricity and lighting that

set him apart from other inventors. His labs designed and manufactured switches, meters, generators, and just about everything else connected with electrification. This is akin to inventing a computer in a laboratory only to discover that, oops, now we need software, monitors, a mouse, printers, scanners, and every other peripheral advertised in the monthly catalogs we all receive from computer suppliers.

Our First Big Power Plant

Edison designed and built his first major power plant in the Big Apple in 1882—a reported 120-volt system in downtown Manhattan. This also was the world’s first principal power station. Unfortunately, Edison built it based on direct current, an approach that would become dated by the next decade, as was proven by one of his employees. Nikola Tesla, a Yugoslavian immigrant who briefly worked at the Edison laboratory in New Jersey in 1884, was on to something with his ideas about alternating current.

Con Edison, which started out as the New York Gas Light Company in 1823, is the current-day result of more than 170 mergers and acquisitions. The nucleus of Con Edison was the Edison Electric Illuminating Company, formed in 1880.

Tesla Needed a Lawyer

Nikola Tesla was another guy who liked applying for patents. By the time of his death in 1943, he held more than 700 patents in the areas of induction motors, generators, fluorescent lights, and steam turbines. Tesla supposedly arrived in America in 1884 with 4¢ in his pocket. (Who knows, maybe it’s one of those stories that claimed a little less money every time Tesla retold it.)

America’s tough when you’ve only got 4¢ to your name. In 1885, Tesla sold his patent rights to his system of alternating current to George Westinghouse, another inventor and industrialist who knew a good electrical system when he saw it.

Tesla established his own laboratory in New York City in 1887. Ever the prankster, he sometimes would use his own body as an electrical conductor to light lamps to show that alternating current was safe. It probably was a great way to impress prospective girlfriends as well. While Westinghouse raked in the big bucks from his newly acquired alternating-current system, Tesla eventually



Bright Idea

Prescient investors in promising industries can reap huge fortunes as those industries grow. Looking back at the nascent electrical and phone industries, it’s easy to see why computer technology, software, and telecommunications are good investments today. The trick, as always, is to know which industries and industry players will succeed.

became the namesake for a unit of measurement for magnetic fields. A *tesla*, as every amateur physicist knows, is equal to one *weber* (a unit of magnetic flux named after German physicist Wilhelm E. Weber, not the barbecue manufacturer) per square meter.

Considered both a genius and an eccentric during his lifetime, Nikola Tesla laid much of the practical and theoretical groundwork for the communications and electrical systems we have today.

Early Safety Measures

Electrical systems were a brand-spanking-new technology in the late nineteenth century, and no small amount of trepidation was associated with them. Wouldn't there be fires? Electrical shocks? Government officials, especially fire departments, took electrification very seriously.

The New York Board of Fire Underwriters, meeting in October 1881, called for standards such as the following:

- “Wires to have 50 percent conductivity above the amount calculated as necessary for the number of lights to be supplied by the wire.”
- “Wires to be thoroughly insulated and doubly coated with some approved material.”
- “Where electricity is conducted into a building from sources other than the building in which it is used, a shut off must be placed at the point of entrance to each building and the supply turned off when the lights are not in use.”
- “Application for permission to use electric lights must be accompanied with a statement of the number and kind of lamps to be used, the estimate of some known electrician of the quantity of electricity required, and a sample of the wire at least three feet in length to be used, with a certificate of said electrician of the carrying capacity of the wire.”



Electrical Elaboration

The first committee meeting for the National Electrical Code (NEC) was held in 1896, and the first code was published the following year. The NEC has adapted to the times and changes in electrical equipment, and it is now more than 1,000 pages long. More than 300 volunteer members of the National Fire Protection Association (NFPA) work on the code and code changes for new editions of the code.

These guys were serious! It's no wonder: They weren't about to take chances with a new technology that was potentially dangerous, despite its useful prospects.

The Standards Change

Once early wiring requirements were established they were stringent, but the size of an individual home service and the subsequent loads were inadequate by today's standards. A 30-amp service with a wood fuse box was typical and sufficient for running lights. Prior to electrification, many homes had gas lighting. Some wiring actually was fished through the gas piping in the walls to the new electric lights that replaced the old gas fixtures.

The turn of the century was a heady time in the field of electricity. Innovators and scientists were improving all the necessary components and generators as well as coming up with new gadgets and conveniences that would run on electricity. Even the newly built New York City subway systems were beholden to this great new power source.

Fuses to Breakers

All new residential construction uses circuit breakers in its service panels, but fuses were first used to distribute electricity through individual circuits. These fuses are still present in older homes where electrical services have not been updated. Although the first circuit breakers date back to as early as 1904, it wasn't until the 1950s, with the introduction of the modern plug-in-type breaker, that they gained universal usage.

Fuses might be dated and less convenient than circuit breakers, but they are perfectly usable under most circumstances. When updating to a new service panel, of course, fuse systems are always replaced.

Just One Ceiling Light

Compared to today's lighting standards, our grandparents and great-grandparents were almost walking around in the dark. A single ceiling light per room was considered an improvement over gas lighting. Can you imagine having only one overhead light in a kitchen? We bathe ourselves in light today, and we love every minute of it. The lighting requirements today in some kitchens alone would have consumed half of a typical home's service requirements back in the 30-amp days.



Positively Shocking

You would assume with the advent of electric lighting that Americans would have beaten a path to electricity's door. Not so! Improved gas-fixture innovations allowed for the continued use of gas lighting for domestic use and streetlights until after World War II. This is the equivalent of using a manual typewriter in the computer age.

Knob-and-Tube Wiring

The earliest wiring system was called *knob-and-tube wiring*, and you'll still find this in houses built prior to the early 1950s. This was an inherently safe system in which the hot wire and the neutral wire ran separate from each other through walls, floors, and ceilings. Each wire was covered with cloth insulation and ran through ceramic tubes when passing *through* floor joist and wall studs or into electrical boxes at lights, switches, and receptacles. The wires were secured to ceramic knobs when they ran *along* a joist or stud.

Electricians were a little anxious about this new electricity stuff, so most original knob-and-tube work is very neatly done. Wires were twisted together, soldered with lead, and then taped to make secure connections. The main problem with knob-and-tube wiring is what happens in the intervening years when homeowners and amateur electricians hack into it (see Chapter 6, "When You Buy a House").

Wiring Evolves

Although knob-and-tube wiring prevailed for years, other types of wiring were developed in attempts to either speed up or simplify installations. If your house was built prior to the 1950s, you might find one of these not-so-fun types of wire in it. Unfortunately, every innovation doesn't stand the test of time.

The following two systems were later contemporaries of knob-and-tube wiring:

- Armor-clad cable
- Multiconductor cable

Armor-clad cable, often called BX, was a trademark of General Electric. It consisted of a narrow metal sheathing wrapped around the hot and neutral conductors. It was mainly installed in the 1920s and 1930s in more expensive housing.

Running the wire in a protective metal wrapping sounds like a good idea, right? It probably was until the metal started rusting and corroding with age. Then the hot wire could short out to the metal wrapping, and in some cases, the wrapping could become red-hot but never blow a fuse. This type of wiring should always be thoroughly inspected by an experienced electrician.

Multiconductor cable carried both the hot and neutral wires in a cloth insulation that was coated with either varnish or shellac. Each wire was separately wrapped in its own insulation as well. As it ages, the insulation becomes very brittle and is almost impossible to work with in some cases.

Current systems use nonmetallic sheathed cable commonly known as Romex, another trade name. This cable is wrapped in thermoplastic, which probably will last so long that future anthropologists will be carbon-dating it in the year 14,500 C.E. This is a very safe wiring system that comes with a grounding wire in addition to the hot and neutral wires, and it allows for relatively quick and efficient installation.

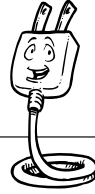

Electrical Elaboration

Some early wiring was installed behind wood molding specifically made to house the wires. A millwork company would cut grooves on the backside of the wood, one groove for the hot wire and one for the neutral. This system had some drawbacks, the most obvious one being wire damage from nails driven through the wood. By the 1930s, wood molding was illegal and no longer was installed.

Creeping Home Power Demands

Early electrical and lighting systems were comparable to our more recent computer, software, and communications industries:

- The first electrical systems offered relatively little power and ran house- and streetlights. The first desktop computers had almost no memory, slow speed, and small hard drives.
- Innovation came fast and furious among very competitive companies and individuals.
- Our demand for more bandwidth, cable, and phone availability is a repeat of our increasing demands for more electricity since the turn of the century.
- All of these industries have improved our standard of living, despite criticisms to the contrary from technophobes.

A typical 30-amp home service has increased to 200 amps in the past 100 years. We've gone from one light per room to multiple lights, multiple receptacles, every appliance imaginable, and entertainment systems all demanding their share of electricity. This has required building and rebuilding an entire infrastructure of dams, generators, long-distance power lines, transformers, and miles and miles of utility poles.

The entire undertaking has been enormous and is entirely taken for granted today. Historical hubris lets us believe that our time is the most innovative and influential to date, but we wouldn't have gotten very far without electrification. Try running your laptop on some of Volta's original batteries or even some of Edison's. You might get enough power to read "Starting Windows 98" on your screen before it shuts off, with your battery drained of any direct current.

The basics of electricity and its delivery systems are pretty well established. Equipment might improve and become more efficient, but until someone rewrites the laws of physics, electricity will continue to be delivered by wires or other conductors from a generating force. You'll still get billed once a month or so for its usage. Nobody said all those electrons would be free, but it remains quite the bargain based on all it provides for us.

The Least You Need to Know

- The history of electricity and electrification is full of pioneering scientists, each building on the knowledge of the others.
- Thomas Edison's biggest contribution was building usable wiring and lighting systems.
- Early electrical systems used knob-and-tube wiring and fuses—both still found in older homes.
- A century of innovation has brought us safe, efficient power and power-delivery systems far beyond the dreams of industry pioneers.

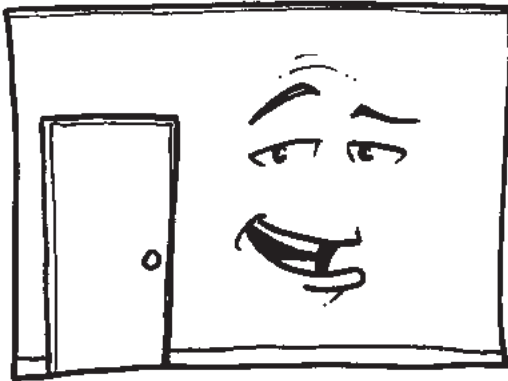

If Your Walls Could Talk

In This Chapter

- National Electrical Code requirements
- Inspecting your home for compliance
- Understanding wiring systems
- Understanding circuit breakers and fuses
- Installing plenty of power

Many horror movies feature haunted houses with fiends, evil spirits, or some other form of calamity lurking behind the walls or under the floors. Bookshelves conceal hidden passages, and trap doors spring beneath the secondary characters, just missing the hero or heroine and plunging them to an unknown fate. Your house isn't anywhere near as fateful—at least it shouldn't be—but it does have some tales to tell behind the drywall or plaster, the walls you stare at every day.

Houses are built according to the building codes at the time of their construction. Even an owner-built house has to meet all code requirements including electrical requirements. As codes change so do construction standards. Any remodeling work you do now has to meet the current code, even if the rest of your house does not.

If your house is old enough, it probably has been remodeled or altered on a number of occasions. It's likely that some of this work is, putting it kindly, code-challenged. You've already taken a superficial look at your wiring. Now let's examine it in more detail. A good starting point, so you'll know what all the fuss is about, is the National Electrical Code.

The National Electrical Code

The National Electrical Code (NEC) is the guiding light behind most electrical installations in the United States. As a rule, local regulations include the NEC along with any specific ordinances imposed by individual building departments. The fact that so many state and city agencies use the NEC affirms the excellence of this code. As a culture, we might have our disagreements from one coast to the other, but we do agree on the National Electrical Code. Interestingly, the NEC is not mandatory and therefore has no regulatory control. It's strictly a set of voluntary guidelines, which is a good thing: If Congress had gotten hold of it and tried to turn it into legislation, we'd still be using candles and kerosene lamps to light our homes.

The NEC is just over 100 years old, and it has changed with the times. The advent of electrical power brought with it the need for standards for equipment, installations, and usage. The initial concerns around electricity were mainly about property protection. Fire underwriters were especially concerned, because they were taking losses due to electrical fires.

New York, the late-nineteenth-century center of the universe, wrote the first requirements for electrical safeguards in 1881. More codes by different industries followed, and in 1892, the Underwriters National Electrical Association consolidated these various codes, although there was still no universal acceptance of one set of rules. Saying enough was enough, the National Electric Light Association called a conference in 1896 to come up with one standard set of rules. The conference included utility representatives, underwriters, inspectors, and just about every key player who was involved with this new electricity business. They diced, spliced, and blended the best parts of all the existing American and European codes. They then tweaked it during a review process, and in 1897, they came up with the National Electrical Code. There have been 48 editions of the code, and the next one is due out in 2002.

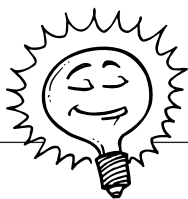

Bright Idea

You don't necessarily need to study the NEC itself to do your electrical work. Most of the rules that apply to home electrical work are commonly known and are discussed in books such as this one. If you have any questions or concerns, point them out in your plans when you apply for a permit and get a ruling before you do the work.

The National Fire Protection Association (NFPA) has administered the NEC since 1911. Harking back to the original NEC, the current code is a product of group consensus with an even greater variety of contributors including labor unions, testing laboratories, regulatory bodies, and consumer groups.

The NEC goes well beyond home electrical systems. Among other things, it covers the following:

- Fiber-optic cables
- Antennas
- Fire alarms
- Marinas

- Carnivals, circuses, and fairs
- Mobile homes
- Gasoline dispensers

Espresso stands and popcorn wagons might not specifically be named, but they're covered, too!

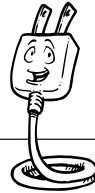

Electrical Elaboration

When I was a kid, my family vacationed at Catawba Island on Lake Erie. (This was Ohio's version of a waterfront resort.) Near our hotel, there was an arcade full of hokey games and amusements that were designed to separate us from our saved weekly allowances. We discovered that, if you put one hand on the metal plunger of the pinball machine and the other hand on the metal casing of the mechanized gypsy fortuneteller, you got a fingertip-to-fingertip shock. This was great fun for endurance contests and for tricking unsuspecting cousins, but it left something to be desired from a safety standpoint.

You and the Code

The NEC exists for your protection. I know we live in an era of business-guru authors and self-improvement advisors extolling everyone to “think outside the box,” to develop new paradigms, and to seek out the “wow” in everything we do. That's fine, just don't try it with your electrical work. The code will help keep you and your family alive and your house from burning down. You can be as imaginative as you want when it comes to selecting fixtures or adding lights, but they have to be wired and installed properly.

Just in case you decide to seek your bliss and express yourself with electrical work that isn't up to code, your local inspector will be equally expressive, but in a way that won't make you very blissful.

Local Rules, Local Inspectors

Ultimately, the NEC isn't the final judge and jury of your electrical work. This role belongs to your local electrical inspector who enforces your local electrical code. How does your local code differ from the NEC? It depends on where you live. Some municipalities stick with and solely enforce the NEC; some have additional rules. Remember,

your local code determines how you or your electrician will do your electrical work, so you must know the regulations.

The electrical inspector wears a variety of hats. An inspector ...

- Interprets the NEC rules and regulations.
- Approves or rejects electrical work.
- Approves fixtures and materials.

Is an inspector always right? Let me put it this way: If you question a judgment or ruling, you had better be able to back it up by quoting chapter and verse from the code. No one is perfect, and an electrical code is an involved and complex document. Mistakes and misinterpretations are made on both sides, but the inspector has the final word. Take some tips from Mr. Etiquette:

- Do your best work, and do it neatly.
- Don't try to hide anything or take shortcuts.
- If your inspector believes you've erred in your work, listen politely and see what you have to do to resolve the problem.



Positively Shocking

Your insurance company can deny any damage claims to your house caused by uninspected electrical work. An inspection proves to your insurance company that the work was done according to the electrical code. If for any reason you do have an electrical fire, at least you can show the workmanship wasn't to blame.

It isn't the inspector's job to show you how to do your work. As a homeowner, you'll have to establish your credibility and competence to do the job, even more so than a trained electrician. An inspection is like the speed limit—you might not like it, but it's there to protect you.

The CEC

Canadians use the Canadian Electrical Code (CEC). You might wonder what this has to do with electrical work on this side of the border, but Alaskans (state motto: It Doesn't Get Any Colder Than This) have had problems in the past with Canadian-built outdoor work modules (portable buildings). Differences in the two electrical codes have resulted in some modules being unacceptable without costly upgrades to meet the NEC. You could probably argue that Alaska should be part of Canada, but it isn't, so the CEC isn't acceptable there.

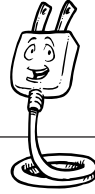

Electrical Elaboration

A real-life example of a change in the National Electrical Code that has prevented human fatalities is the requirement to install ground-fault circuit interrupters (GFCIs). Statistics have shown that the installation of GFCIs in bathrooms, kitchens, the outdoors, and other potentially damp, hazardous locations has saved lives.

Underwriters Laboratory

Underwriters Laboratory is the organization that brings us the ubiquitous “UL” tags on just about everything we plug in or turn on. What does this group do? In the organization’s own words, UL “is an independent, not-for-profit, product-safety-testing and -certification organization.” Underwriters Laboratory was established in 1894 to test products for the emerging electrical industry. It has managed to attach more than 14 billion UL tags to products all over the world.

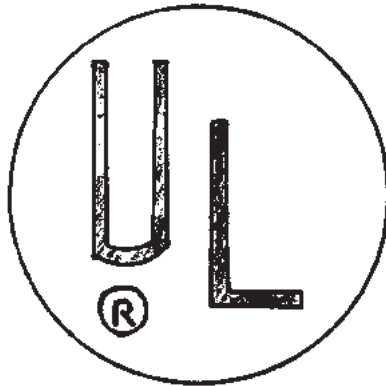

The UL tag is known 'round the world.

UL is *the* leader in product testing and certification. If a manufacturer wants its new gadget to gain ready consumer acceptance, it applies for the UL tag, because no retail outlet in its right mind would sell anything electrical without it. You can find the organization at www.ul.com on the Web.

The UL, along with the Consumer Product Safety Commission and the National Electrical Manufacturer's Association, helped establish the not-for-profit National Electrical Safety Foundation (NESF) in 1994. The Foundation's mission is to improve our awareness of electrical safety at home, work, and school. The NESF's Web site, www.nesf.org, points out the following cheery statistics:

- One person is electrocuted in his or her home every 25 hours, and more than 350 people die in over 40,000 residential electrical fires every year (Consumer Product Safety Commission data).
- One worker is electrocuted on the job every day (Occupational Safety and Health Administration data).
- Personal-property damage from fires exceeds \$2 billion a year.

These are not-so-subtle hints that you can't take electrical safety for granted. The NESF offers tips, Web links, and a safety booklet, and it's all free for the asking.

Are You Up-to-Date?

Now that you've got a hint of the hell-and-brimstone that awaits you if you ignore electrical safety and code requirements, you can take a fresh look at your own system. As we've already mentioned, a new system can almost be ignored until you're ready to add to it. A system meeting the 1996 or 1999 NEC will be grounded, will have plenty of receptacles including GFCIs, and will have power properly distributed among a series of circuits throughout your house.



Positively Shocking

It's not an uncommon practice to do home remodeling without permits and inspections. Common acceptance doesn't mean it's advisable, especially when doing structural or mechanical work. I know of one seller who was later sued when his illegal remodeling came to light after the buyer took possession. Lawsuits aside, you don't want to be on the receiving end of unsafe work.

What if you have an older system or one that's been altered? Your home might have had an addition or two put on by past owners. How can you be sure these were done according to past building codes? Let's start with some basics as you review your electrical system.

There are some basic differences between older and newer electrical systems, such as ...

- The presence or absence of a grounding conductor.
- Fuses versus circuit breakers.
- Nonpolarized outlets versus polarized outlets.

Two-Wire and Three-Wire Systems

A two-wire system means you don't have a grounding conductor. This is the bare copper or green-insulation-clad wire attached to a *grounding electrode* outside your

house. Alternatively, the *grounding conductor* can be attached to a water pipe near your electrical panel.

Your first clue to determine whether your system has a grounding conductor comes from your receptacles. A two-pronged receptacle usually doesn't have a ground; a three-pronged outlet *should* have a ground. An older house might well have three-pronged outlets, but there is no guarantee that they were installed with grounds (another peril of uninspected remodeling work). To be certain, you must either ...

- Test each outlet with a circuit tester, which will indicate the presence of a ground wire.
- Take the cover plate off each receptacle and look for the ground wire.

Of the two methods, using a circuit tester is easier (see Chapter 7, "Caution Signs and Safety Concerns"). If your system isn't grounded, it doesn't mean you're in grave danger and should refrain from turning on the lights ever again. It does mean, however, that it's a dated system that lacks a modern safety feature—a safety feature that people lived without until the 1960s. Unless there's been a deep conspiracy to cover up massive electrocutions of homeowners over the years, you can still live with an old two-wire system (but it's always a good idea to upgrade).

A grounded receptacle connects any exposed metal sections of an appliance or lamp to the house grounding system. This means an errant current shouldn't pass through the metal shell of your washing machine and turn your wash day into something unexpected.

A three-pronged, grounded receptacle is the made-to-fit receiving end for a three-pronged plug. Remember, electrical systems are nice and logical. If you have a two-pronged outlet and a three-pronged plug, they don't go together, no matter how hard you push on the plug. Before you ask, cutting off the grounding pin from the plug is a bad idea. Buy an adapter, which is available at any hardware store, instead.

Feeling Polarized

Have you ever noticed how some receptacles (and all new ones) have two different-size slots? These are polarized receptacles, and they're the perfect fit for polarized plugs. In each case, one side (the slot of the outlet and one prong of the plug) is larger than the other. This is not done to intentionally annoy you, but if you have an old house, it can be a real inconvenience when plugging in new electrical devices.



Ask an Electrician

A **grounding electrode** is a metal pipe or rod, often iron or steel-galvanized, that is driven at least eight feet into the ground outside your house. The material must be at least $\frac{5}{8}$ inch in diameter and must offer a resistance of 25 ohms or less. The **grounding conductor** carries any excess voltage to the ground to prevent injury or damage to electrical equipment.

A modern three-pronged, grounded, and polarized receptacle.

(Photo courtesy of Leviton Manufacturing Co., Inc.)

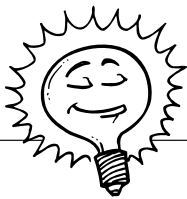

Bright Idea

A two-pronged plug adapter used to convert three-pronged plugs for use in older receptacles also can be used for adapting polarized plugs. The adapter enables them to be plugged in to nonpolarized outlets.

A polarized receptacle is constructed so a polarized plug can be inserted only one way. It also ensures that the hot leads and the neutral wires line up from outlet to plug. It might be tempting to file down the larger prong on a polarized plug, but trust me, this is a bad idea, too. These are all parts of a system, and they're made to work together and be kept intact. This is no place for quick fixes. Either adapt to the limitations of your older electrical system, or bring it up to date.

Circuit Breakers vs. Fuses

Circuit breakers and fuses perform the same task: They interrupt electrical power when the current demand is too high. If you plug a 2,200-watt personal surfing pool complete with Oahu-inspired monster waves into a 15-amp circuit, be prepared to wipe out along with

the power. If the breaker doesn't trip or the fuse burn out, the wire connecting the receptacle to the panel could overheat and possibly start a fire. You probably wouldn't realize anything was burning because the wiring is concealed inside your walls.

Circuit breakers have been the mainstay for residential electrical installations for more than 40 years. They're convenient, dependable, and reusable. What's not to like about them?

This One Blows

Although there's a variety of fuses, most old residential systems use the glass, screw-in type called *plug fuses*. These fuses feature a narrow metal strip, visible through the glass, that quickly melts when too much current is starting to move through the circuit. Fuses are rated by amperage and cannot be reused after they burn out or "blow."

A fuse system generally is safe if it's used according to its design. This means ...

- Always using the correct size fuse.
- Being sure the fuse is screwed in tightly.
- Not listening to your old uncle Bob, who says you can replace a fuse with a Lincoln-head penny and call it good.

The glass of a blown-out fuse might look smoky, or more noticeably, the strip will be melted or separated. Before replacing it, you should turn off any electrical load that might have caused the overload. Some electricians recommend that you also turn off the main switch to the fuse box before removing and replacing the old fuse. Whatever you do, *be sure to keep one hand behind your back or in your pocket!* You don't want both hands near the box, because if both accidentally touch it, you can become part of a circuit and electrocute yourself.

This One Trips

Breakers, as previously explained, "trip" when a metallic strip heats up, bends, and forces spring-loaded contacts apart. After tripping, they can be reset by pushing the breaker's switch all the way "off" and then back over to the "on" position. When resetting a circuit breaker, be sure to ...

- First find out what caused the breaker to trip and shut it off.
- Use only one hand and keep the other one away from the service panel.

A circuit map will identify the circuits controlled by each breaker or fuse (see Chapter 5, "More Wall Talk").

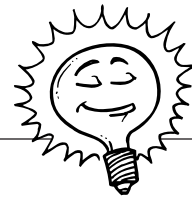

Bright Idea

Always keep spare fuses on hand, at least for the common 15- and 20-amp sizes. Keep the fuses stored with a flashlight so you don't trip around in the dark while replacing a burned-out fuse.

Plug fuse; circuit breaker.

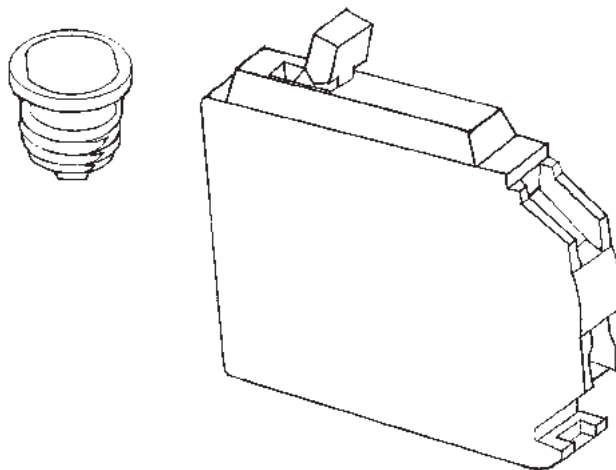

Circuit breakers, like fuses, are rated by amperage. Don't even consider installing a higher-rated breaker in place of a lower one. If you have repeated tripping, you're overloading the circuit and need to change your usage habits or upgrade the circuit.

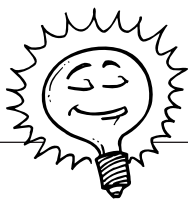

Bright Idea

If you repeatedly trip a circuit breaker or burn out a fuse, you need to decrease your power demands. Examine your usage. You might be using a high-wattage appliance such as a hair dryer or a plug-in heater in addition to the circuit's normal load. Do a load calculation and determine what you'll have to change.

The Main Shutoff

Fuse boxes and service panels both have some kind of main shutoff mechanism, and you should know how to use it. The NEC says that you cannot have more than six disconnects—no more than six fuses, breakers, or levers of some kind—to turn off the service. Fuse boxes usually have either a single pull-down handle or two 50-amp pullout fuse holders to disconnect the service.

In a service panel, you will have either a main breaker or a series of breakers in the top half of some older panels that, when shut off, will disconnect the service. Remember, even with the breakers shutoff or the fuses removed, without the meter removed from the meter socket, the panel is still hot where the large wires come in from outside your house.

In case of an emergency in which you must get the power off quickly and cannot identify the specific fuse or breaker, the main shutoff will do the job. Keep in

mind that your entire house can go dark. Be sure to have a flashlight close to your fuse box or service panel.

The More Power the Better

Harry Truman once made a comment about fully equipped armed forces, saying something like, “If we’ve got ‘em, then we won’t have to use ‘em.” He figured the more power the country had, the more of a deterrent it would be to future aggressors (if only he’d been right). He was on to something about power, though: It’s better to have plenty of it than to not have enough. The same is true with your electrical system.

There is nothing wasteful or ecologically sinful about having a minimum 200-amp service in your house. No one says you have to use all that electricity all the time or even ever. Heed the Boy Scout motto: Be prepared!

Look to Future Needs

None of us knows what the future will bring, except maybe dial-up psychics: They know your call will bring them \$2.95 a minute. Everything else is a roll of the dice. You might add a second story to your house, set up a woodworking shop in the basement, or double the size of your kitchen. You even could add a casino extension off your garage if your state legislature decides that home-based gambling operations are more in keeping with its ideas about family values.

Any and all of these possibilities require electric power. If you’re replacing your current system, think more rather than less because, in this case, less is definitely not more.

Cost Comparisons

Trying to provide local price comparisons in a nationally sold book is like judging a national chili contest: What works in Massachusetts isn’t going to cut it in Texas. In other words, there are a lot of variables, including ...

- Local labor prices.
- The brand of service being installed.
- The difficulty of an individual installation.
- Permit and utility fees.

That said, we can make some generalizations based on the size of the service alone. The most common sizes of services are 100-, 125-, and 200-amp *single-phase*, three-wire systems. The approximate difference in cost—and you should always check with your local supplier or electrician—between installing a 100-amp service and a 125-amp service is around \$100 plus permit and utility fees. The difference between a 125-amp service and a 200-amp service is around \$150. The difference will increase depending on the length of conduit and wire required for the installation.

Based on a \$150,000 house, the extra \$150 equals one tenth of 1 percent of your home’s value, or an espresso a week for one year. If it’s a budget consideration, skip the coffee and go with the bigger service.



Ask an Electrician

A **single-phase** system or line provided by your utility can carry electrical loads suitable to meet the needs of residential customers and smaller commercial clients. A **phase** describes the voltage or current relationship of two alternating waveforms as the electricity travels down a conductor or, in this case, a wire.



Positively Shocking

If you have an older service panel, it should be checked by a licensed electrician to make sure it's safe. Some panels have shown regular safety problems and are not considered reliable by many electricians.

Panels and More Panels

Every electrician has favorite electrical components to recommend, and this includes service panels. Electricians also have panels that they avoid and existing, older panels that they recommend tearing out yesterday if not sooner. This is touchy ground, and anything I or the electricians I have worked with recommend will be subject to criticism in some quarters. With that caveat, I can recommend the following guidelines for choosing a panel:

- You get what you pay for, so skip the low-end panels.
- Ask as many electricians, electrical suppliers, and builders of high-end homes as you can what panel they recommend; one or two names should keep coming up.
- Buy the best panels made by your manufacturer of choice rather than lower-end units made to compete with similar low-end units from chain discount stores.

Consider what a panel does: It acts as the major line of defense in the event of an electrical problem. You want the best panel possible rather than the most basic. They all will be UL-approved, but it's better to go with a panel that will meet higher standards than the bare minimum. You wouldn't buy the cheapest brakes for the family minivan, and this is the same attitude you should take with your electrical panel.

What does my electrician recommend? He uses the Square D QO panel. Others recommend Cutler-Hammer or Siemens. All of these are reliable brand names that will serve you well.

The Least You Need to Know

- ▶ The National Electrical Code (NEC) is a set of guidelines for electrical installations.
- ▶ The final judge of your electrical work is your local electrical inspector.
- ▶ The safety features in a newer, three-wire electrical system include circuit breakers, a grounding conductor, and three-pronged, polarized receptacles.
- ▶ For a small difference in cost, you can install a larger electrical service that will more easily take care of future needs and remodeling.

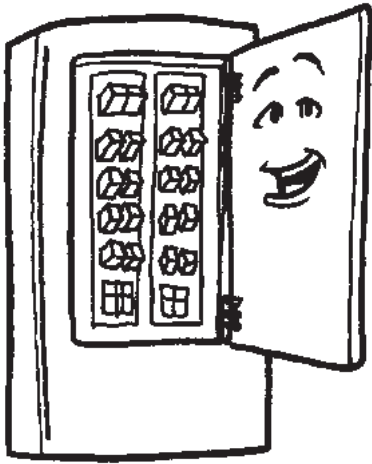

More Wall Talk

In This Chapter

- Understanding how circuits work
- Ground-fault circuit interrupters
- One house, different conductors
- Living with old wiring
- Wiring hazards
- An old-house checklist

Now that you know about fuses and circuit breakers, it's time to familiarize yourself with the circuits they control. A circuit is a continuous loop of electrical current. It travels from a power source (your utility through your service panel or fuse box) along a "hot" conductor (the black or red wire) as a load demands it. The electricity then travels back to the panel along the white or neutral wire. When you activate a load by flipping a light switch or turning on a food processor, you allow the circuit to pass through and light up the room or grind up basil leaves to make pesto.

Circuits aren't just random pathways for a bunch of juvenile-delinquent electrons out to cause trouble. They are determined by voltage or electromotive force (EMF). Amperage is the rate at which these electrons flow, and it's held in check by the size of your circuit breaker or fuse and the gauge of the wire. The size of the wire used in an individual circuit is influenced by the loads it must supply and even the distance the electricity must travel. Some circuits are dedicated. That is, they only control a single load such as a clothes dryer.

Your circuits run along conductors or wire, which usually is made from copper. Over the years, different wiring systems have been used. An older home that's been remodeled might have more than one type of wire or cable, and these can be a problem if they are not properly connected or are overloaded. This chapter will give you a better idea of what shape your electrical system is in and what you need to consider before altering it.

Branching Out to Break Up the Load

You could connect all of your 120-volt electrical loads—lights, bedroom receptacles, the refrigerator, and so on—to one big circuit breaker, and they would still function. Replacing a broken switch or installing a new light fixture then would mean turning

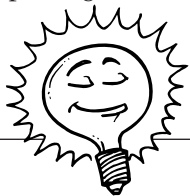

Bright Idea

It's usually better to have more circuits than to have fewer, even if some of them seem underused. This way, you have extra capacity for future expansion without having to run entirely new circuits.

off all the power to the house rather than just the power to one particular room. If your housecleaning service trips this giant breaker with a new 55-horsepower industrial vacuum cleaner while you are out of town and is afraid to reset it, you can kiss that frozen Copper River salmon in the freezer good-bye.

Electrical current is broken down into individual circuits—called *branch circuits*—for safety and convenience. You don't want the entire house to go dark because a GFCI in the kitchen tripped due to a faulty appliance. Each circuit is designed to carry a certain amperage and to provide enough current to meet the wattage demands of receptacles, lights, and appliances. The following figure shows a standard residential distribution of circuits.



Ask an Electrician

A **branch circuit** is separate and independent from any other circuit. It has its own circuit breaker or fuse, wiring, and loads. Your service panel has a number of branch circuits for both 120- and 240-volt loads.

A circuit is laid out logically, or at least it should be. This means that a 15-amp lighting circuit will control lights in, say, three continuous rooms rather than in three rooms at opposite corners and on different floors of the house. Several forces work together to help a circuit do its job safely.

Amps, Watts, and Wire Gauge Working Together

You remember that amps, or amperes, are a measure of an electrical current's strength or flow. A watt measures the electrical power itself. That is, it measures the amount of electricity consumed by an appliance or another fixture as it converts the electricity into something useful to us. A circuit is sized to allow a certain amount of electricity to run to a given number of

loads. The loads are measured in watts, which is why you can only have a certain number of receptacles and lights on a circuit. Too many running at once demands more juice than the circuit can safely provide before a protective device in the form of a circuit breaker or fuse steps in like a responsible bartender and cuts you off.

Typical branch circuits.

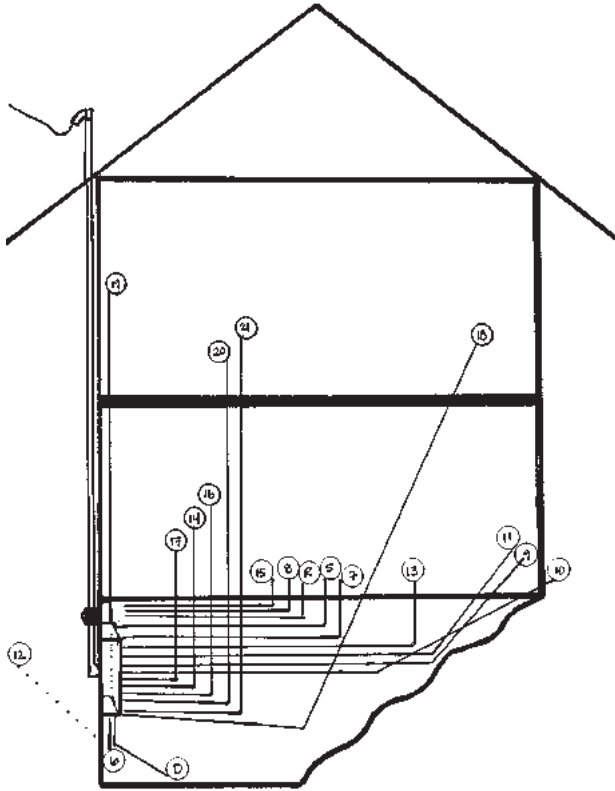

The amount of current carried to the various loads also is determined by the size of the wire running between the service panel and the loads. If your wire is too small for the amount of current the load is demanding, it will have a high resistance and will over-heat. This is okay for the heating element in your toaster but not for your house wiring. The Wire Gauge Rating table in Chapter 2, “What Is Electricity Anyway?” shows the ampacity rating for various gauges of wire. A 20-amp circuit, which usually runs small appliances, requires No.12 wire. Many electricians recommend No.12 wire as the minimum size wire for residential use, even though the code accepts No.14 wire as the minimum-size conductor for branch circuit wiring.

Circuits and Runs

Circuits can be divided by type:

- General-purpose or lighting circuits
- Dedicated circuits
- Small-appliance circuits

Lighting circuits include most receptacles in living areas other than the kitchen, bathrooms, and workrooms. This is appropriate for most receptacles because we generally use them for small loads such as floor and table lamps or clock radios. Some receptacles will only be used for night-lights; others might rarely or never be used. Even light fixtures have varying loads depending on the wattage of their lamps. They can vary from 25 watts to 150 watts.

What happens when you plug in something larger such as a room air conditioner? What if you have a water heater or an electric range that also requires large amounts of current? These loads call for dedicated circuits, which are so-named because they only supply power to one specific load.

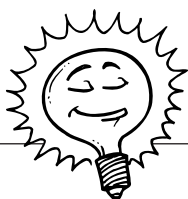

Bright Idea

Loads that demand large, intermittent amounts of power, such as a table saw in a workshop, also should be run on dedicated circuits. Power tools can easily trip a circuit breaker when they're first switched on if the circuit already is in full use from other loads.

Dedicated circuits include those for ...

- Major appliances.
- Refrigerators.
- Computers.

It's easy to understand why a major appliance needs a dedicated circuit, but what about refrigerators and computers? Even a large refrigerator-freezer combination is rated at about 500 to 700 watts, and a computer is far less. (My notebook PC is a minuscule 36 watts.) These fall into a different category of dedicated circuits that aren't based on a demand for electrical current but on their specific activity. It isn't critical for your refrigerator to be on its own circuit from a power-demand standpoint, but if another load somewhere else on the circuit's run trips the entire circuit, your refrigerator will shut down, and you will be looking at a lot of spoiled food. Some jurisdictions' codes require that the refrigerator be on a dedicated circuit.

Computers don't store food, but they do store your data. Most people readily agree that we should back up and save our documents and spreadsheets while we're working on them, but then we cheerfully continue working without doing either.

If a breaker trips because that lamp you keep meaning to rewire finally shorts, it's good-bye to the last chapter of the Great American Novel you've been working on for the last five years. Whenever practical, it's a good idea to install a dedicated 20-amp circuit for your computer and its peripherals.

Know Your Circuits with a Circuit Map

Electricians follow the minimalist school of writing: They write as little as possible when listing the circuits on the form inside the service panel door. An electrician will write "Lighting circuits," for example, across the space designating one or two specific breakers. That's all well and good, but a more useful description would say, "Ceiling lights in master bedroom and north bedroom, in second-floor hallway, and at top of stairs." These written descriptions need more room than most factory-supplied lists provide, unless the writing is very small.

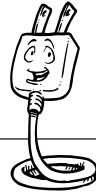

Electrical Elaboration

Developing a circuit map is more than simply an exercise in knowing which fuse or circuit breaker controls which loads. It also can make you aware of overloaded circuits that have had too many loads added to them by misinformed homeowners. If a circuit appears to be overloaded, do a load calculation and determine if a load should be removed. Most likely, the problem will be an add-on done after the system was installed and probably done without an inspection or permit.

In a new house, the electrician's list usually is adequate because the wiring is so straightforward. In an old house, however, the list needs to be more specific, especially if past homeowners have added their own electrical marks when they lived in your home. Every owner has different needs, and they manifest themselves with receptacles, lights, and switches in places that will make no apparent sense to you but are perfectly logical for someone else. These include lights in crawl spaces, switches on attic rafters, and receptacles in closets. You don't need to know their history, but you should know which fuse or circuit breaker controls them, especially if they are tied in to the middle of a circuit and can potentially cause problems.

Drawing your own circuit map can be done alone, but it is best done with some helping hands. To come up with your map, you'll need the following:

- Paper and pen for recording
- Lights and radios to plug into receptacles
- Extra people spread around your house

What Are Friends For?

You'll be testing your circuits one at a time. It's just a matter of flipping a breaker or removing a fuse, observing what goes out, and writing it down. This means every light will have to be turned on, and every receptacle will need something plugged into it. This is where the lights and radios come in. It's important that you know where every receptacle and odd light is located and that you account for all of them.



Positively Shocking

In older homes, homeowners and do-it-yourselfers sometimes play fast and loose with good wiring practices and connect a new wire to the nearest convenient old wire. This can result in some odd circuits that might take longer to figure out when you make up your circuit map. Don't leave any receptacle or light unaccounted for just because it doesn't turn off when other loads in the room do.

As previously mentioned, this job is easier to do if you can fill up your house with some friends. As you turn the power off one circuit at a time, they can yell out what went off, and you can write it down in your notebook. This can be a fun project in a big house with people running and shouting as lights go off all over the place. Carefully write down everything as specifically as possible and redo the list later on your computer. Print a list to attach to your service panel or fuse box, and maintain the file on a disk to record new circuits as they are added or old ones as they are changed.

GFCIs—Ground-Fault Circuit Interrupters

The code requirement to install GFCIs has been a real lifesaver for homeowners. One government statistic suggests that a GFCI installed in every home in America could prevent more than two thirds of all residential electrocutions. A GFCI measures the current flowing into the outlet through the black or hot wire and the current outflow through the neutral or white wire (see the following figure). If the GFCI detects any difference greater than 7 milliamperes, it shuts off the current. Why? Because any difference in the current is an indication that the current is somehow shorting or "leaking"—maybe through you! It might be a short in an appliance such as a hair dryer or an electric mixer. These are dangerous situations, and a GFCI will shut down far faster (in as little as $\frac{1}{40}$ of a second) than a standard circuit breaker or fuse.



A GFCI.

(Photo courtesy of Leviton Manufacturing Co., Inc.)

An older home may or may not have GFCIs, but it can be retrofitted with them (see Chapters 19, “Kitchen Power,” or 20, “Bathroom Wiring”).

A GFCI won’t always prevent an initial shock, but it does prevent a lethal one. The current NEC calls for GFCIs to be installed in a number of locations, including ...

- Bathrooms.
- Kitchen counters.
- Outdoors.
- Garage walls.
- Unfinished basements and crawl spaces.

Why have these areas been singled out? They all have something in common: water or water pipes, both of which are good at seducing a current away from its righteous path back to your panel or fuse box to take a trip through your body instead. There’s a reason why various cads in the movies get knocked off while in the bathtub when an irked female character throws a plugged-in curling iron into the water. If you use a defective hair dryer when touching the water faucet in your own bathroom, you’ll be glad you have a GFCI installed.

A modern electrical system will have GFCIs in the form of either outlets or breakers, although the latter are more expensive. The presence of a GFCI in an old system is a demonstration that a past owner was concerned enough to attempt at least a partial modernization of the system. GFCIs are covered more completely in Chapter 11, “Switches and Receptacles.”

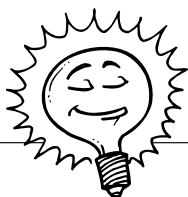

Bright Idea

Test all your GFCIs monthly. It's simple and quick, and it ensures that the outlets are working properly. Plug a small night-light into the outlet and press the "Test" button. The light should turn off, and the "Reset" button should pop out. This trips or disengages the outlet. Press the "Reset" button to complete the test. If the "Reset" button does not pop out, you might have a defective GFCI, and it should be inspected or replaced. Note that a GFCI installed on an ungrounded circuit will not trip when the "Test" button is pressed. The "Test" button will only work if the GFCI receptacle is grounded.

Wire Systems Old and New

A main difference between old electrical systems and new ones is the presence of a grounding conductor in contemporary wiring. Modern cable contains all three wires—hot, neutral, and ground—wrapped in protective thermoplastic insulation. Your house might have cable running through it rather than the old knob-and-tube or metal-wrapped BX cable systems, but this is no guarantee that it's got a grounding conductor. Cable installed in the 1950s only contained a hot wire and a neutral wire. The only way you'll know for sure with your own cable is to check your electrical panel (see Chapter 17, "Service with an Attitude").

You've already read that old wiring isn't necessarily bad wiring, with the (sometimes) exception of BX cable, which can become damaged and be conducive to short circuits. The abuse usually occurs later as it gets hacked into. Replacing an entire system is expensive. New services installed in older homes usually incorporate some of the existing wiring into the new panel (unless it's judged to be too corroded or unsafe). You and your electrician need to decide ...

- If you can add any loads to your existing system.
- The compatibility of your current wiring with a new service panel.
- Whether your system is safe given its current usage.
- The practicality of completely rewiring your house.
- The cost versus the benefits.



Electrical Elaboration

If you decide to rewire your house and update your electrical system, remember one cardinal rule about electricians: They don't do wall repair! Electricians will cut into walls and ceilings, but you or another contractor will have to repair the plaster or plasterboard. The best electricians make the fewest possible openings to pull wires.

Do You Need to Replace?

Installing a new 200-amp service panel in an older, two-story house, replacing all the existing circuits, and adding new ones to bring the entire system up to code—all this is an expensive proposition. The service alone can cost roughly \$1,800 to \$2,000. You can easily spend four times that amount wiring the house, depending on its size and the complexity of the new system. I hesitate to quote figures because every house is different, as are local labor rates, but an electrician can give you a ballpark figure, which is subject to change when an actual estimate is drawn up.

Some people will replace and upgrade just to be on the safe side, while others *should* replace and upgrade. The following are signs that you should consider changing your electrical system:

- An undersized service (60 to 100 amps for a large, two-story, all-electric house)
- An insufficient number of circuits
- Too few receptacles and switch-controlled lights
- A lack of GFCIs
- Overloaded circuits with fuses that burn out regularly
- Frayed or deteriorated insulation on your current wiring

Too often, homeowners ignore the basic mechanics of a house (electrical, plumbing, and heating/air conditioning) when remodeling and pay too much attention to aesthetics, such as cabinetry, painting, and floor finishes. It's easy to understand why: These are characteristics we see day after day. No one sees the new, modern, sheathed cable running through the walls to equally new grounded outlets, all of which are nicely distributed on properly sized circuits. I can't begin to count the number of older homes I've been in that were beautifully redecorated but still only had one or two receptacles—and old receptacles at that—per room. There's no excuse for living in an underpowered house as we begin the twenty-first century.

Jump Up to 200 Amps

If you've got a small service, say up to 100 amps with a fuse box, in a two-story house and you're thinking of upgrading to circuit breakers, replace it with a 200-amp panel. Don't argue about it or debate its need, just do it. The last house we owned was a 1924, three-bedroom, one-story bungalow on a street of one-story bungalows. You could easily maintain that it only needed a 125-amp service, but a funny thing happened as Seattle real-estate prices headed toward the stratosphere: These one-story homes started becoming two stories. Owners decided it was more cost-effective to stay put and add on rather than to move. Five of our former neighbors on one block did this very remodeling to their homes. My point is that you cannot predict future needs. Given the relatively small cost difference between a 125-amp service and a 200-amp panel, there's no point in installing the smaller service in a two-story house.

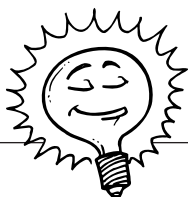

Bright Idea

It's best to avoid disturbing elaborate plasterwork in older homes when rewiring. Carefully removing baseboards enables you to cut holes in your walls where they will go unnoticed while still allowing you to drill through wall studs and place your receptacles where you want them.



Positively Shocking

Even new electrical equipment can be potentially hazardous. In April 1999, the Consumer Product Safety Commission (CPSC), which can be found at www.cpsc.gov, announced a recall of more than 12,000 service entrance devices from a major manufacturer. These boxes contained the electric meter and breaker panel and were reported to have potential electrical arcing problems after one reported incident during a residential installation. Always have suspect service panels inspected by an electrician.

One exception to my 200-amp rule is the presence of gas appliances. Our first house, for example, was adequately serviced by a 125-amp panel because we had a gas furnace, water heater, stove, and clothes dryer. As a result, the biggest single electrical loads in the house were the refrigerator and the washing machine, neither of which were huge draws on the system.

Good Wire, Bad Wiring

An original service of knob-and-tube wiring, if properly installed, is and can remain a safe electrical system. Left alone, it would satisfy the electrical demand for which it was designed without any problems. When it isn't left alone, or when the loads increase and stretch the system's capacity, the problems and hazards begin. Add-ons are pretty easy to spot, especially those done by homeowners. Dead giveaways include ...

- Sloppy installation.
- Loose, unsecured wires.
- Wires running across the edge of floor joist rather than passing through them in unfinished basements.
- Improper taping at connections through the use of unapproved materials such as masking or adhesive tape.
- Mixing two different gauges of wire on the same circuit.

Other issues include worn and frayed insulation and brittle wire ends where they are attached to loads or switches. This problem is exacerbated as the wire ends get bent and unbent when switches, receptacles, and light fixtures are replaced over the years due to general wear and tear or the desire for something new.

When New and Old Collide

Old electrical systems can be safely added onto if the following considerations are followed:

- You have room in your service panel or fuse box for additional circuits.

- Individual existing circuits aren't fully utilized and can carry an additional load.
- The wiring and insulation of these circuits are intact and not worn.
- You properly join new wire to old.

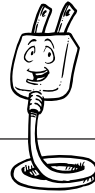

Electrical Elaboration

Humans aren't the only ones who cause problems with old wiring—think rats! These rodents must gnaw to keep their teeth filed down, and electrical wire makes a dandy chew toy. Rats live inside insulation near hot-water heaters and furnaces. Mice aren't much better, settling down inside large appliances such as dryers or stoves and chewing on the wiring. Orkin Pest Control suggests that many fires of "unknown cause" might have been caused by rodents chewing through electrical wires. Cable television and phone wires also are targets. In New York City, rats have been known to gnaw through concrete—but that's New York for you.

You can't see inside your walls and observe how every receptacle, switch, and light has been wired, but you can get an idea if an addition has been made to the original system. Look for the following telltale signs:

- A receptacle or switch style that doesn't match the others in your house (The cover plates also might be a different style.)
- A fixture located in an odd place such as a crawl space
- A receptacle that isn't as evenly spaced as others
- A receptacle that is cut into a plaster wall while all the others are cut into the baseboards—a common feature in turn-of-the-century homes
- Any switch or receptacle that is surface-mounted on a wall rather than cut into the wall

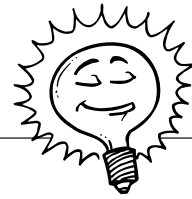

Bright Idea

Replacing your current system offers the opportunity to relocate your service panel to a safer or more convenient location. It also might be a fitting time to bury your service entrance conductors or supply leads (the wires from the utility pole to your service panel) underground rather than having them suspended overhead where they are exposed to the weather and possible falling tree branches during windy weather.

Do you have unfinished attic or basement space? These are prime areas for added fixtures to be tied into existing wiring and should be checked thoroughly.

Location, Location

One consideration with old systems is the location of your fuse box. It's often located outside the rear or kitchen door, which isn't too convenient if you have to change a fuse on a cold winter night. Modern service panels with circuit breakers are located inside and are protected from the weather. Locations vary depending on the type and cost of the house, but typically the panels are found in basements, garages, or utility rooms.

Your Checklist

By now, you've got a better idea how fuses, circuit breakers, circuits, wires, and fixtures all come together as your house's electrical system. The older your house, the more important this knowledge will be as you evaluate your system's safety and consider future remodeling. The following checklist summarizes what you should be looking for in your system.

Electrical Checklist

Type of service

- Fuses
- Circuit breakers

Size of service

- 60 amps
- 100 amps
- 125 amps
- 150 amps
- 200 amps

Type of wiring

- Knob-and-tube
- BX
- Ungrounded cable
- Grounded cable

Dedicated circuits

- Major appliances
- Refrigerator
- Workshop
- Office computer

Electrical Checklist

GFCIs

- Kitchen
- Bathroom
- Basement
- Garage
- Outside

Sufficient circuits?

- Yes
- No

Do any circuits regularly trip?

- Yes
- No

Number of receptacles

- ___ Kitchen
- ___ Bathroom
- ___ Bedrooms
- ___ Living room
- ___ Dining room
- ___ Hallways

Wall switches for all lights?

- Yes
- No

Are all outlets polarized?

- Yes
- No

Are all outlets grounded?

- Yes
- No

Has the system been altered?

- Yes
- No

Does the work look professional?

- Yes
- No

Has your system been evaluated by an electrician?

- Yes
- No

Remember to follow all the safety recommendations in this book, especially if you have an old system.

The Least You Need to Know

- Branch circuits ensure an even and safe distribution of electricity throughout your house.
- A circuit map will tell you exactly which fuse or circuit breaker controls each load in your system.
- GFCIs should be installed in every kitchen and bathroom and next to any laundry or bar sinks, especially if you have an old electrical system.
- The main problem with old wiring is questionable work that was done *after* the system was installed.
- If you're installing a new service panel with circuit breakers, think larger rather than a minimal service size.



When You Buy a House

In This Chapter

- House plans and inspections
- Some simple tests
- Aluminum wiring problems and issues
- Checking outdoor wiring
- Testing everything
- Keeping upgrade costs in mind

Your electrical inspection and checklist don't just apply to your current home but also to a prospective residence. Despite the diligence of inspectors, they still can make errors when checking and approving newly constructed homes and remodeled additions. Any home purchase, regardless of the age of the house, should include a general inspection and an electrical inspection. This inspection will be more exacting than one in your own home because you will have no familiarity with a house that's new to you, whereas you already know that your kitchen lights start flickering an SOS in Morse code every time you turn on your food processor and that they need to be corrected.

An inspection will tell you more than simply the condition of the system. It will enable you to consider changes and additions and their possible costs before you buy. These factors can affect your purchase negotiations, especially if major work is called for such as installing a new service panel.

New homes, both those of your own design and those under construction by developers, deserve special attention with regard to your electrical needs. The planning and construction phases are certainly the ideal times to wire for as many light fixtures, receptacles, dedicated circuits for your computers, and specialized cable for phones and media as you desire. If you're not sure about future TV or phone locations, wire every room for them and don't worry about it. The labor cost to install wiring is far cheaper when the walls are open to the framing studs than after they're finished.

Grab your checklist from Chapter 5, "More Wall Talk," and your Sunday newspaper's real-estate section and hit those open houses!

Caveat Emptor or Buyer Beware!

Whether it's new, old, or in its teenage years, you're taking a certain chance when you buy a house. All the warranties and assurances in the world won't prevent leaks, squeaks, and lawsuits over roofing or siding materials, for example. I can speak from experience on the last one, because our house—purchased new in 1994—features the infamous Louisiana-Pacific LP Siding, the subject of a massive class-action suit and a multi-million-dollar settlement. The same scrutiny applies to electrical work.

You have the law on your side with seller disclosure *Form 17* and builder warranties, but you want to preclude any problems after you move in by ferreting them out before signing the final papers. An inspection and a disclosure form keep a seller honest and can bring up unseen problems that were unknown even to the seller.



Ask an Electrician

Form 17 is a legal document that sellers are required to fill out unless the buyer takes the property as-is. The seller must disclose any known material issues that will affect the purchaser including structural and mechanical issues. The seller must disclose any remodeling work and state *whether the work was or was not done under a permit and inspection.*

Who Does the Inspection?

Professional house inspectors are very much a mixed bag. Some are extremely thorough and produce very detailed reports; others are less-impressive and depend too much on checklists and filling in the blanks. The very best person to inspect your electrical system is a licensed electrician, but you don't want to be dragging one along every time you look at a prospective house. Save that for final candidates. Meanwhile, you can do a preliminary inspection yourself.

The Preliminaries

Following the checklist in Chapter 5 will give you an overall view of an electrical system. Note whether the house has fuses or circuit breakers and the size of the service. Look for an overall impression of the condition of the wiring and the number of loads. A sure

sign of a shortage of receptacles is the presence of multiple-outlet plug strips or multiple outlet plug-ins, especially in the kitchen.

Are there enough ceiling lights? Do rooms seem too dark? Keep in mind that every room should have a switch-controlled light fixture. This *doesn't* mean the fixture has to be installed in the ceiling or on the wall. A switch-controlled receptacle, a common feature in new homes, meets this code requirement because a floor or table lamp can be plugged into the receptacle and turned on from a wall switch.

Testing! Testing!

With a couple of simple testing devices, you can check for wiring problems including ...

- ▶ Whether power is present at a device or fixture.
- ▶ Grounding continuity.
- ▶ Defective receptacles, switches, and fixtures.
- ▶ Whether outlets are properly wired.

A voltage tester should be in every electrical do-it-yourselfer's toolbox. Consisting of two probes connected at a plastic housing that contains a small neon bulb, a voltage tester lights up when it detects an electrical current. It also can detect which incoming wire is the hot wire and the presence of a grounding conductor.

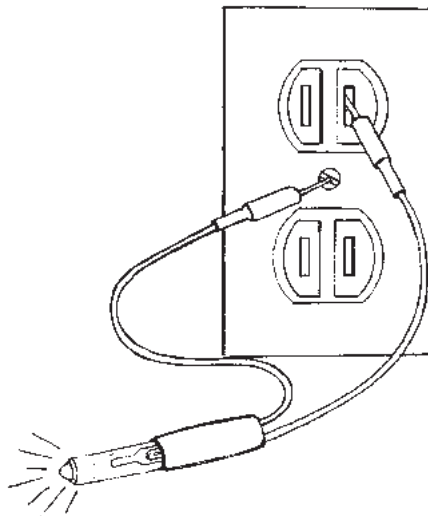

Positively Shocking

When examining a fuse box, note the number of 15-amp circuits. If you don't see any, someone probably messed with the box and installed 20-amp fuses instead—never a recommended practice. Lighting circuits almost always are 15 amps.

An inexpensive voltage tester.

The probes of the tester either are inserted into a receptacle's slots or are held against the terminal screws that secure the wire to the receptacle. If the probes do not detect a current when inside the slots but do detect one when held against the terminal screws, this indicates that the receptacle itself needs replacement. If there's no current at the screws, there's a problem with the circuit.

Note: With back-wired devices, the probes are inserted in the slots next to the wires. The receptacle will have to be removed from the box. To safely remove the receptacle, turn the power off at the panel first, then remove the screws securing the receptacle, pull it out, and, finally, test it.



Electrical Elaboration

There are two different means of attaching wires to receptacles and switches: back wiring and side wiring. The hot and neutral wires can either be inserted into two push-in terminals (also called terminal apertures or wire wells) on the back of the device (back-wired) or be secured with terminal screws on the sides (side-wired). Side wiring is considered by some electricians to be more secure, and it makes the wires accessible for testing. Back wiring is a faster installation, however. Test a back-wired device by inserting the probes into the release slots (which are next to the push-in terminals).

The same holds true for switches and fixtures. There are two tests for electrical switches.

After removing the cover plate, be sure the switch is in the "Off" position. Place one probe on the metal box that holds the switch; if the box is plastic or nonmetallic, place the probe on the white or neutral wire. You'll have to remove the switch from the box in order to reach the neutral wire; be sure to turn the power off first and then turn it on again for your test. Place the second probe on each of the black wires, or on the terminal screws holding the wires if they're side wired. One of them—the line side or black wire supplying power from the circuit—should light up. If neither of them does, there is a problem with the circuit.

After you find the line side, turn the switch to "On" and place the probe on the other black wire, which is the load side, while keeping the other probe on the neutral wire. In the "On" position, the switch completes the circuit and the load side carries power to the light fixture. If the tester doesn't light up, the switch is faulty and needs to be replaced.

You test a fixture by holding the probes against each of the terminal screws with the light switch "On." If your test shows a current, but the light isn't working, you need either a new fixture or new light bulbs.

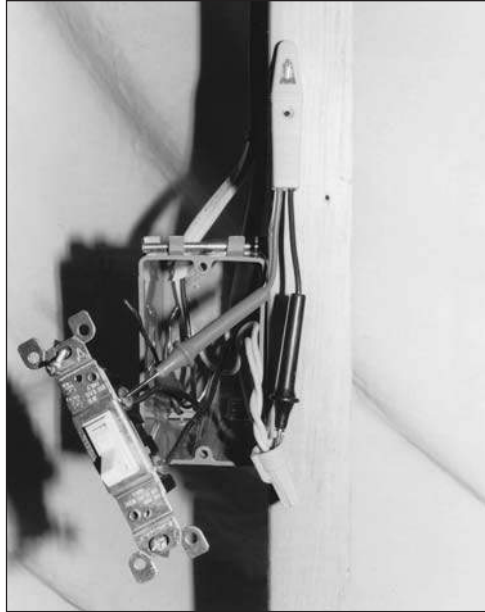

How to test a switch: line side terminal.

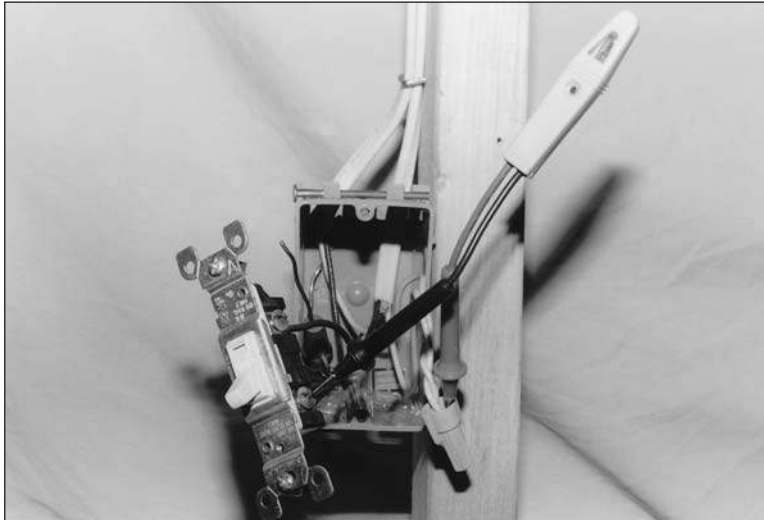

How to test a switch: load side terminal.

The Other Tool You Need

Second to the voltage tester in your box of tricks is a receptacle analyzer. This is a plug-in tester that analyzes different wiring problems after being plugged into a live circuit. Three lights on the bottom of the terminal light up in different combinations to show you what the tester detects. A printed guide on the analyzer points out the various electrical foibles a receptacle can suffer from.

A receptacle analyzer.

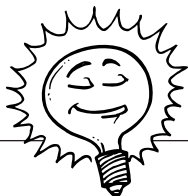
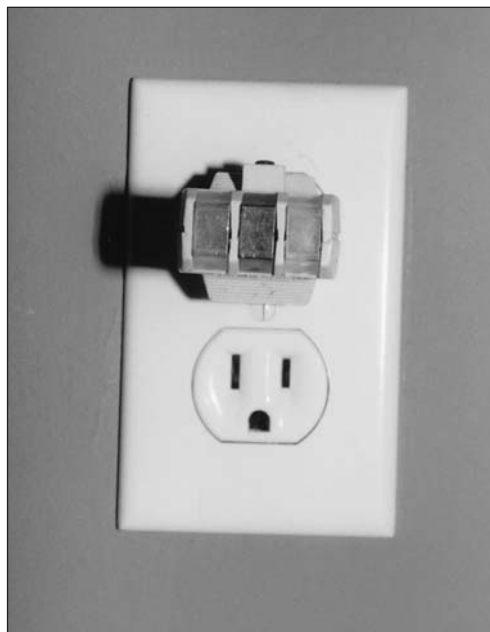

Bright Idea

You should change the batteries in your smoke detectors once a year to make sure they'll still be working in case of an electrical outage. Mark your calendar using a yearly event such as your birthday (or maybe October 8, the anniversary of the Great Chicago Fire).

Smoke Alarms

The best smoke-alarm systems are connected to your house's wiring and have a battery backup. A stand-alone, battery-powered alarm is better than nothing at all, but a wired/battery system is preferred. Check the house for smoke detectors and then check the detectors themselves. Press the test button on each smoke detector. If you don't hear the annoying screech designed to just about wake the dead, you have a dead battery, a dead circuit, or a dead detector.

Aluminum Wiring

Human beings always are looking to substitute new, less-expensive versions of successful products that have been tried and true for years. Sometimes this works well (a cheap, hand-held hair dryer versus a full-size, hair salon, sit-in-the-chair-and-put-your-head-inside hair dryer); sometimes it doesn't (Yugos and Vegas versus most other automobiles). In the electrical world, the use of aluminum wire for running branch circuits falls into the latter category of substitutes gone bad.

Aluminum wire was installed in at least 1.5 million homes between 1965 and 1973. The material cost was as little as 50 percent of the price of copper wire, which made it a hit with homebuilders, even if it ended up being a false bargain for homebuyers. Unforeseen problems with the connections of the wire to devices lead to it being labeled a potential fire hazard and ultimately banned from most residential use.

Although I could find no figures as to the actual number of homes that burned down due to electrical fires from aluminum wiring, there were enough to initiate studies, accusations, lawsuits, and not-so-veiled warnings regarding its use. The problem wasn't immediately apparent because aluminum-wired circuits can take years to reach a failure point while still remaining functional. According to Dr. Jesse Aronstein (in his report "Reducing the Fire Hazard in Aluminum-Wired Homes," prepared for the Electrical Safety Conference-Electrical Fires at the University of Wisconsin-Extension in March 1982 and revised May 10, 1996), a seemingly indefatigable researcher in this area, "The probability of an aluminum-wired connection overheating in a home varies considerably according to the types of connections, the installation methods used, and the circuit usage, along with many other factors. Without detailed knowledge of the installation in a particular home, it is not possible to provide specific advice on corrective measures."

Is aluminum wiring a red flag in your house-purchasing adventure? Yes, but there are ways to deal with it intelligently.

What's the Story?

According to the U.S. Consumer Product Safety Commission (CPSC), problems with aluminum wiring manufactured prior to 1972 include ...

- Expansion and contraction of wires.
- Easily damaged during installation, because it's a soft metal.
- Corrosion.

Aluminum wiring heats up more easily than copper wire from electrical currents passing through it because it has a higher resistance. As a result, aluminum wire must be one gauge size larger for a given circuit than if copper were used. Thus, a 15-amp circuit could use No.14 copper wire but would require No.12 aluminum.

As a conductor, aluminum heats up when a current passes through it. Like any heated wire, it expands and contracts as it heats and cools, but



Positively Shocking

CPSC research indicates that homes containing aluminum wire manufactured before 1972 are 55 times more likely to have one or more connections reach "fire-hazard condition" than homes wired with copper. These conditions are defined as receptacle cover-plate screws reaching a temperature of 300°F, the presence of sparking, or charred material around the receptacle. Wiring produced after 1972 solved some, but not most, of the material's failings.

aluminum is damaged more than copper by this cycle of temperature changes. Adding to this problem are the connections (or terminations) at devices and fixtures. Aluminum tends to oxidize when it comes in contact with some other types of metals—the same ones that often compose the termination material (such as brass terminal screws). Now we've got a metal that's already touchy about heating and cooling, and it's also corroding and offering even more resistance to the current. The corrosion adds to aluminum's natural resistance, making that resistance even worse. As a result ...

- The connections deteriorate and loosen at the terminals.
- There is arcing or a discharge of electricity across the gap between the end of the wire and the terminal.
- There is possibly enough heat to melt the insulation and cause a fire.

Aluminum wiring can easily be damaged because it's so soft. If a piece gets nicked while the insulation is being stripped during installation, the nicked area is weakened and can deteriorate faster than the rest of the wire as it heats up. So much for that 50 percent savings in material cost when this stuff was installed!

What You Should Look For

Aluminum wiring primarily affects housing built from 1965 to 1973, but it also can be present in additions and remodeled sections of older homes if the work was done during these years. The first thing to look for during your snooping is the word "aluminum" printed or embossed on the plastic sheathing of the electrical cable. If the cable isn't observable in an attic space or a basement ceiling, look in the service panel. Remove the cover plates and look at individual switches and receptacles to see whether the wire ends are copper- or silver-colored.



Electrical Elaboration

Despite its dangerous reputation for branch circuits, aluminum wire is a good choice for conducting large currents such as the main service line to your house. It's lighter weight, so it's less affected by strong winds or added weight from winter ice. It's also less expensive than copper. Because there are fewer termination points (only those at your service head, where the service conductors enter your house, and at the service panel), they are tightly connected and easy to monitor.

Warning: Aluminum Wiring Ahead

Not every house with aluminum wiring is an automatic time bomb waiting to burst into flames like a vampire caught outside at dawn. The warning signs used to check for overheating problems and loose connections include ...

- ▶ Warm cover plates.
- ▶ Flickering lights.
- ▶ No power in a circuit.
- ▶ Sparks and arcing.

These signs are discounted by Dr. Aronstein, who states that they are not entirely reliable, do not always take place, or occur at a late stage in the failure of the wiring. He does, however, suggest turning the power off and examining individual devices and loads with a flashlight for the following:

- ▶ Charred or discolored plastic
- ▶ Back-wired devices
- ▶ Excessive tarnishing at the ends of the wires
- ▶ Damage to the thermoplastic sheathing including melting and bubbling

Some wiring might not show any signs of deterioration because a particular circuit might never have had enough loads on it to cause overheating. If you plug a portable heater in, however, the status quo might change rapidly. The best defense is to monitor these circuits if their usage changes.

Any of these defects is cause for action. Are they enough of a reason for you to walk away from a potential property purchase? No, because even though technology caused the problems, it also can resolve them.

Solutions

The obvious answer to any aluminum-wiring problems or potential problems is to replace it all with copper. How practical is this, however, if you have limited unfinished areas such as crawl spaces to run new wire or if you live in a condominium? You also would have to patch and repaint everywhere. Fortunately, there are other solutions.

Aluminum wiring is most dangerous at the connections and termination points. The accepted remedy is to use a short piece of copper wire (usually referred to as a “pig-tail”) to connect the aluminum wire to the switch, receptacle, or appliance after treating the exposed ends of the aluminum wire with antioxidizing paste (see the following figure). The best method, which is CPSC-approved as the only permanent repair, is done with the use of a special power crimping tool manufactured by AMP Incorporated (P.O. Box 3608, Harrisburg, PA 17105; 1-800-522-7652). This tool installs



Positively Shocking

When repairing aluminum circuit wiring, it's important that all devices be addressed and all wires be spliced and crimped rather than only the most noticeable problems. Every switch, receptacle, and fixture is a potential fire hazard and should be repaired by a licensed electrician.

a metal sleeve called a COP/ALUM parallel splice connector. This handy tool, which you'll never find in a hardware store, permanently attaches a piece of copper wire to the existing aluminum wire along with the sleeve. The connection is then covered with heat-shrunk insulation. This work should be done by professional electricians, not homeowners, so forget about trying it yourself with a cheaper crimping tool or another means of connecting the wires together. This is a specialized procedure that requires training provided by the manufacturer.

Note that some electrical boxes—the enclosures around switches, receptacles, and other devices—might not be big enough to house the additional pig-tailed connectors and wire. It might be necessary to replace the box with a larger size, which will involve cutting into the wall and doing some patchwork to the plaster or plasterboard.

A typical pigtail with NMB copper cable.

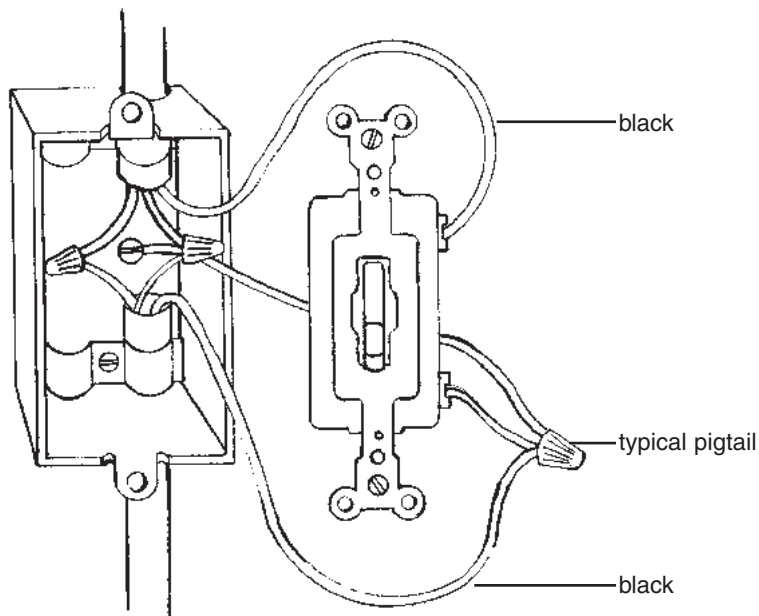

A partial repair can be made by replacing all standard outlets and switches with UL-approved devices marked "CU/AL," which indicates that they can be used with either copper or aluminum wiring. The CPSC does not recommend these devices as a complete repair. Under no circumstances should any device connected to aluminum wire be back-wired. (If there are problems, you won't see them.)

The consumer booklet “Repairing Aluminum Wiring” (Publication 516) is available by writing the CPSC at U.S. Consumer Product Safety Commission, Washington, DC 20207.

The Great Outdoors

Look closely at any outdoor lighting and receptacles. Bad wiring practices outdoors are especially unsafe because of the exposure to weather, especially moisture. All outdoor receptacles should be GFCI protected and should be enclosed by weatherproof boxes. Electrical cable must either be buried in plastic or rigid metal conduit or be the UF (underground feeder) type, which has a very heavy plastic sheathing.

Cable rated for outdoor use must be buried at specified depths (see Chapter 21, “The Great Outdoors”). Anything buried too shallow for its particular type and circumstances is in violation of the code. Digging is a lot of work. I know one homeowner who did only a minimal burying, and the cable resurfaced from time to time during gardening chores. At another house, the roots of a growing tree gradually yanked a shallowly buried (and poorly located) cable to the surface.

Old, corroded switches and receptacles with broken covers are a sure sign of needed electrical repairs. Check the service panel or fuse box and see if the outdoor fixtures are running on their own circuit. You might find that they are tied into another branch circuit inside the house, which isn’t a terrific idea.

Garages are another center for do-it-yourself add-ons run amok. The wiring here should be equal to any circuit inside your house and should not be a disarray of wires and extension cords stapled to the walls. Be sure to take note of any questionable work.

Check the power lines as well for obstructions or worn cables. These are the utility company’s responsibility, but you need to report the problems so it can repair them.

Attic Insulation Problems

Modern nonmetallic electrical cable is tough stuff, and it doesn’t require the open-air environment of older knob-and-tube wiring for heat dissipation. Even if you pack it up against insulation, it just laughs as long as cable-nibbling rodents don’t take up residence. Knob-and-tube wiring, on the other hand, can have a dysfunctional relationship with insulation due to heat buildup. It isn’t unusual to find knob-and-tube

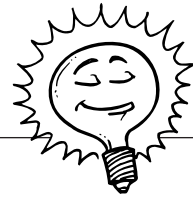

Bright Idea

Digging trenches for outdoor wiring is a lot of work, so combine it with another task such as bringing in a new gas line or service line for your plumbing. As long as you follow the local code requirements for maintaining a safe distance between pipes and wires, they all can share the same trench.

wiring buried under the blow-in type of insulation, so check your local code to see if this is allowed.

Older light fixtures also need clearance from insulation because they really build up heat, especially if they have more than one light bulb. Although newer zero-clearance fixtures are now sold, never assume they have been installed in an older house until you examine the fixture itself.

A Breath of Fresh Air

Modern homes are tightly insulated, but they have plenty of mechanized ventilation in the form of kitchen and bathroom fans as well as whole-house fans on timers.

These forms of ventilation try to ensure a regular exchange of fresh air, which is particularly helpful the first year after construction because carpets, plastic laminates,

and paints give off all kinds of fun fumes, thanks to the wonderful world of chemistry. An old house is naturally ventilated through gaps in the windows, doors, and walls. Even so, you still should have fans in the kitchen and bathrooms. If these rooms remain unventilated, moisture hangs around and throws a party for its friends mildew and mold. This means more frequent cleaning and painting as well as a reminder that you burned the pancakes at breakfast because you can still smell them during dinner. Check for fans and make sure they're working. Small fans (those with a low *CFM* or *cubic feet per minute*), whose main activity is making noise instead of getting the moisture and odors out, are next to useless and should be noted for replacement.



Ask an Electrician

CFM (cubic feet per minute) is a measure of how much air a fan can move. A good fan can move—and remove—a lot of air quickly.

More Testing

Turn on all the lights in each room. Next turn on various appliances, even hair dryers in the bathroom, and watch the lights for flickering. A slight flicker isn't unusual, but a permanent dimming is a sign of an overloaded system. The same is true if an appliance repeatedly causes a circuit to trip.

If a switch doesn't appear to control anything when you flip it on, it can be a sign of an old disconnected load or circuit. A do-it-yourselfer might leave the switch in place, but an electrician would remove it and cover the box with a blank cover plate. You want to check for signs that work was done properly, not slipshod.

Some Final Points

Does the prospective home have a security system? If you want one, make a note regarding its installation and approximate cost. Modern systems have battery-powered motion detectors that don't require hard wiring, but the basic unit itself is wired, which means you need to supply power to it. This might not be a big deal, but it's one more thing to add to your electrical wish list.

Do all the rooms have heat, either from a central heating system or electric room heaters? Some older homes have ancient heating systems and might only have one heating vent in an upstairs landing rather than heating for each individual bedroom. This means you'll have the expense of supplying heat either with new ductwork (and probably a new furnace) or by running circuits for electric heating.

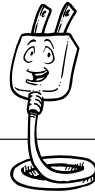

Electrical Elaboration

Check your local code while you consider installing individual electric room heaters. Some cities and municipalities don't like to increase electrical demand any more than they have to, and they might require you to upgrade your house to higher insulation standards, including insulated windows, if you install electric heat. They would much rather you use gas or oil heat, which does not affect their utility loads.

Old homes offer a certain charm and comfort that are difficult to duplicate in most modern housing. Leaded windows, wide oak entry doors, and crown molding running along the ceilings aren't common features in new construction. Neither are fuse boxes, tacky wiring repairs, and a shortage of receptacles and lights. Updating an old system will have to be figured into your budget (and ultimately your purchasing considerations) when you start house hunting. Throw in a new roof, plumbing, floor refinishing, and a kitchen addition, and Old World charm takes on an expanded definition—bring money!

A complete house inspection will make you a more knowledgeable homebuyer and will prepare you for the true cost of purchase.

The Least You Need to Know

- Always do a thorough electrical inspection of any prospective house purchase.
- A voltage tester and a receptacle analyzer are two inexpensive but indispensable tools for testing your circuits and electrical devices.
- Learning to live comfortably with aluminum wiring usually requires the services of an electrician.
- Kitchens and bathrooms need ventilation fans—usually the bigger the better.

Part 2

Safety, Tools, and Contractors

A modern electrical system should be both safe and convenient. All of its components, from the transformer on the utility pole to your imported espresso machine, are supposed to work together in quiet, Buddhist harmony as electrons zip through branch circuits. When you introduce bad karma in the form of overloaded circuits, wiring that doesn't meet code, or unsafe work practices, you can forget about reaching electrical enlightenment anytime soon. You need to maintain a safe environment in your day-to-day dealings with electricity and when doing your own work on the system.

There's a saying that you can tell the quality of a worker by the quality of the tools used on the job and the way they're stored and maintained. This is a little too simplistic (a Wall Street Journal article, for instance, featured homeowners with a lot more money than skills buying tools that were clearly beyond their abilities), but good tools will make your job easier. Consider the value of your time when you work up a tool budget. How do you measure the frustration factor and the lost time from using an underpowered drill because it cost \$30 less than a more appropriate one? You don't need the very best tools because you won't be doing electrical work for a living, but you also don't want to try and slide by using your kids' "Building Trades for Tots Toolbox."

Safety has been an issue with electricity since the days of Thomas Edison and the first large electrification projects. It's still an issue despite the multitude of advances we've made since the first light bulb was invented. Every year, there are thousands of injuries and electrical fires in the United States, and you don't want to add to the statistics. I will emphasize over and over throughout this book that you need to work safely and follow the local code requirements. Electrical safety also applies to everything you plug in and turn on, so I'll discuss those items, too.





Caution Signs and Safety Concerns

In This Chapter

- Skip the shocks
- Common electrical problems
- Safe work practices
- Fire, a major possibility
- The best practice is vigilance

At different times in our childhood, well-meaning parents, teachers, and other uninvited authority figures decided we needed a lesson on what they viewed as one of life's serious dangers. These lessons usually consisted of terse descriptions of the horrors and grave consequences that would befall us if we ignored the lessons, which most of us did. I can confidently say that I didn't go blind from sitting too close to the television, nor did I ever catch pneumonia from going outside with my coat unbuttoned in the dead of Ohio's winters.

Electricity is a different matter, however, and here *I* must become parental for your own good. (I'm sure that phrase brings back a few memories.) One wrong electrical move can result in injury or even death for you or your loved ones, not to mention fire damage to your home. No one is immune to accidents, including experienced electricians. As a homeowner and do-it-yourselfer, you should keep yourself safe and be even more cautious than a professional.

A brand-new electrical system doesn't give you license to abuse it or to test its limits just for the fun of it. Sticking your house key into a ground-fault circuit interrupter (GFCI) receptacle while grabbing hold of your bathroom sink's faucet isn't recommended, even if the GFCI should shut down when it detects your act of lunacy. There's always a chance it *won't* shut down because it's defective. Of course, if you've been following safe electrical practices, you would know this because you would test your GFCIs every month.

With a little common sense (another childhood admonition), you'll be able to safely inhabit and work on your electrical system and fill your home with lighting, receptacles, and multimedia features from top to bottom.



Positively Shocking

It's the salt in water that makes it so conductive. When the salts dissolve, they form electrically charged ions that attract the charges of an electric current. Even the purest water in a scientific laboratory will conduct a minute amount of current. If you're standing in water or a damp area, you're more likely to conduct current. Our own body salts, carried through the sweat glands, also make us more conductive.

Shocks Galore

Every time we use electricity or are near it, there's a chance we could get shocked. Sometimes the chance is remote, such as when turning on a living room ceiling light. Other times, the chance is very good, such as when plugging in a string of worn, patched, and taped-together Christmas tree lights left over from the days of the Harry Truman administration. We talk about shock and its big brother, electrocution, but what exactly are they? Why are they so hazardous to our health?

Electricity basically is lazy and is not always interested in staying on the straight and narrow path of an alternating current. Given the choice of making the return trip along the neutral wire or taking a shortcut, it will opt for the shortcut every time, even if it means traveling through your extremities. Electricity seeks the easiest path to the ground, and any available conductor—metal, water, you—will do the job. Because our bodies are 70 percent water, we make it easy for errant electricity to hitch a ride, and it does so without any hesitation. When our skin is dry, it blocks electricity pretty

well but not when there's water around or the current is sizable. The size of the current and the duration of our exposure to it are the real health issues.

When You Can't Let Go

When an electrical current starts passing through your body, it doesn't take much for you to become energized and very attached to that current. The "can't let go" level (or freezing current) for adults is small, around 10 milliamps. Young children can get

stuck at half that level. The path of the current is of critical importance as well. A hand-to-foot pathway will involve vital organs, especially the heart, and this can have serious consequences.

The following are some effects of an electrical shock:

- Knocking someone down or away from the source of the shock
- Respiration disruption
- Unconsciousness
- Muscle spasms
- Seizures
- Interrupting the heartbeat
- Severe burns
- Cardiac arrest

The longer the contact and the greater the current, the greater the injuries. A young adult in good health will be less affected by an electrical shock than a very young child or an elderly person, but you still don't want to take any chances.

If the current is great enough, third-degree body burns can result at the points of entry and exit. Burns damage and destroy the skin, further breaking down its resistance to the current.

How Much Can You Take?

Once again, we run into Ohm's Law of electrical resistance. In the case of a shock or an electrocution, the amount of current zapping its way through the body is determined by the following formula:

$$I = E/R$$

I = Electrical current

E = Voltage

R = Resistance of the body

Every body offers a different degree of resistance, but that doesn't mean you want to challenge the averages. The National Electric Code (NEC) figures five *milliamps* to be the safe upper limit of exposure for children and adults. Even at this level, you still can be injured by your reaction to the shock such as jumping back and tripping over the rim of a bathtub.



Ask an Electrician

A **milliamp** is a measure of electrical current. It's very small, equal to one thousandth of an amp or ampere. Its abbreviation is **ma**.

Timing Is Everything

The longer a victim is exposed to an electric current, the greater the chance of critical injury. In addition to burns, there is also the loss of muscular control, breathing difficulties as the chest contracts involuntarily, and ventricular fibrillation of the heart. This last effect comes up repeatedly in any discussion of severe electric shock. It refers to rapid, irregular heartbeats and equally irregular fluttering of the heart muscle.

It's one thing to have your heart skip a beat or two because you're head-over-heels in love, but it's quite another to have its pumping activity disrupted because of a faulty circuit. The former usually is a lot of fun, but the latter can do you in if it goes on for too long.

Know Your First Aid

Chances are, you'll never have to rescue anyone on the receiving end of a severe electric shock unless you work in certain construction specialties. Any of us can be caught in a lightning storm, but the chances of being struck by lightning are remote. Nevertheless, it's worth being prepared in the event of an unforeseen accident.

There are a few cardinal rules to remember when helping electrocution victims:

- Assume that the victim is still in contact with the current.
- Never touch the victim until you're certain the current has been shut off or the victim has been removed from the current. (Otherwise, you can be electrocuted, too.)
- If you can safely do so, shut off the power source at the fuse box or service panel. If it's more practical, pull the plug from the receptacle.
- Push or pull the person from the power source using something nonconductive such as a wooden broom, a rubber mat, or a plastic chair. Don't use anything made of metal.
- Never directly touch the source of the current.
- If the victim has stopped breathing, call 911 and begin CPR. (If the situation warrants, call 911 before attempting any rescue.)

In the event of a high-voltage electrocution such as an industrial situation or contact with power lines, do not attempt any direct rescue. Currents this strong can jump beyond the victim and hit the rescuer as well. Call the fire department and keep others at a safe distance.

Summer lightning storms bring their share of electrocutions as well. A bolt of lightning can carry millions of volts of electricity, far more than a misbehaving kitchen receptacle. When you assist a lightning victim, the current already has passed through, so you don't have to worry about being electrocuted as well (unless lightning decides to strike twice, of course).



Positively Shocking

If you ever suddenly find yourself near a downed power line, keep yourself grounded by shuffling away to safety. Running will break contact with the ground and set you up for a shock.

The Source of the Problem

Most electrical injuries are preventable. They typically result from ...

- Work that isn't done to code and is not inspected.
- Defective fixtures, devices, or appliances.
- Human error.

The major purpose of the NEC and your local codes is to prevent injury and property damage from the use of electricity. Even when all the electrical ducks are lined up in a nice, neat row, human error or ignorance comes into play because we regularly ignore good safety practices. Grade yourself by taking our first *Complete Idiot's Guide* electrical quiz and see how you do.

Quiz #1

When you see a worn electrical cord on a lamp or an appliance, do you ...

- A. Tell yourself it adds to the ambiance of your home?
- B. Wrap it with lots and lots of electrical tape?
- C. Replace it with a new, same-size cord?

When you turn on an electrical appliance, do you ...

- A. Make sure your hands are dripping wet?
- B. Grab on to a water faucet for balance?
- C. Dry your hands and stand away from the sink?

Before cleaning the bread crumbs from your toaster, do you ...

- A. Grab the cord and give it a yank?
- B. Not even bother to unplug it?
- C. Grasp the plug and pull?

Before working on an electrical circuit, do you ...

- A. Stick a screwdriver in a receptacle to check the current?
- B. Make sure you're standing on a very wet surface?
- C. Turn the power off at the breaker or fuse and stand on a dry board if the floor is damp?

To power the garage door opener in your detached garage, should you ...

- A. String a series of extension cords together and run them between your house and the garage, leaving them out in all kinds of weather?
- B. Try to run a wire off your washing machine's receptacle?
- C. Run a separate circuit with properly buried cable?

Okay, it's a trick quiz. If you answered anything other than "C" for any question, go back and start reading this book again. It isn't just major electrical work that requires vigilance; everyday stuff is dangerous, too. Problems can be prevented with even the simplest practices such as ...

- Installing childproof safety caps on all receptacles.
- Avoiding overloading circuits with too many loads.
- Keeping ladders and tree branches away from power lines.
- Unplugging all small appliances when not in use.
- Turning off the power to any receptacle or switch that feels excessively warm to the touch. Follow up by having the circuit checked. (Note that dimmers are an exception: Often the heat created by the dimming function is dissipated through the screws holding the cover plate on.)
- Not tucking in an electric blanket or covering it with another blanket to avoid excess heat buildup.
- Keeping extension cord use to a minimum and never running cords under carpets or rugs.
- Replacing broken cover plates on switches and receptacles so wiring isn't exposed.
- Never leaving a lamp socket without a light bulb in it by replacing burned-out lamps immediately. Only replace them with lamps of the same wattage or lower, never exceeding the manufacturer's recommendation.

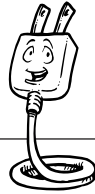

Electrical Elaboration

Some electrical engineers have gone into the consulting business as forensic engineers. Their services are regularly used in lawsuits involving electrical mishaps. Forensic engineers investigate electrocutions, electrical failures, and pain and suffering as the result of electrical problems. They also conduct accident reconstruction. They testify and consult on anything from problem infant monitors that injure a child to massive industrial accidents.

Safe Work Practices

The mundane world of GFCIs and using the proper-size light bulb in your light fixtures just scratches the surface of electrical safety. Its importance is heightened when you do any repairs or alterations to your system. It's like the difference between swimming in the shallow end of the pool and jumping into the deep end with the big kids. Unlike the big kids, who literally sink or swim based on their skill level, you can stack the deck in your favor with a few preemptive moves.

The number-one, top-of-the-list safety rule in electrical work is this: Make sure the current is off, and if it isn't, shut it off! After the power is off, any fumbling with the wires will be a forgiving experience instead of a highly charged one. An inexpensive voltage tester can tell you in seconds whether a current is hot.

Plugging a tool or a light into a receptacle is *not* an adequate way to test whether a circuit is on. The receptacle might be defective. Always test the conducting wires themselves with your voltage tester.

Turn It Off!

Shut the power off by either removing the fuse or flipping the circuit breaker. After the power is off, *hang a sign on the service panel stating that you are working and that the power should remain off!* You don't want someone flipping the breaker on thinking that it tripped.



Positively Shocking

Remove any rings or jewelry before doing any electrical work. These are dandy little conductors when they come in contact with a live circuit. Can't get your wedding ring off? Wrapping it with multiple layers of electrical tape will help, but this is no guarantee against shock. Wearing a work glove will give you additional insulation, but it gives you less flexibility to do the work.

One Hand Behind Your Back

An electrical current needs to travel from point to point to complete a circuit. If you grab the end of a hot wire with one hand and touch a water pipe with the other, you provide the current with a path as it travels through you. The same is true if you're standing on wet ground; the current will travel toward your feet. For this reason, whenever you change a fuse or flip a circuit breaker, you should use only one hand. The other hand should be behind your back or in your pocket. In other words, your other hand should be away from the service panel or fuse box. You don't want it to accidentally come into contact with any metal surfaces in the box because that completes a pathway for the current.

Test, Test, Test

Even if you've turned off the power to a particular circuit, check every device and fixture along the way before you do any work on them. You should take this precaution in case a light switch or receptacle is wired into a different circuit than the one you're working on. Industrial and construction electrical accidents happen regularly because workers find equipment or circuits to be energized when they believed the power was shut off.

On Dry Ground

When it comes to electricity, dry is good and wet is bad (unless you're the U.S. Army trying to electrocute some prehistoric swamp creature in a cheesy, 1950s monster movie). Never stand in a puddle or on damp ground when working on your electrical system. Always find a dry piece of wood or another insulating material to stand on while working. If you must work during wet weather, wear thick-soled rubber boots. Better yet, wait for a dry day (always an iffy situation here in the Northwest, unfortunately).

Watch That Ladder

Metal ladders and overhead power lines are a bad combination. Every year, painters and tree trimmers learn this the hard way, resulting in injuries and electrocutions. Using power tools while working off a metal ladder also can be hazardous, especially during wet weather.

Electricians use wood or fiberglass stepladders and fiberglass extension ladders when they work. Fiberglass is nonconductive; wood also is an excellent insulator as long as it's dry. Most extension ladders aimed at the homeowner market are inexpensive metal ladders. If you're doing any serious overhead electrical work, however, a wood or fiberglass ladder is the better choice.

Tool Health

Modern tools either are *double-insulated* or come with a ground pin in a three-pronged plug. Power tools greatly speed up just about any job, but you can't take them for granted. Tools with frayed cords, cracked casings, or incidents of sparking should be repaired or replaced. This is especially important with heavier-duty tools if they have metal casings. The casings can become energized if there's a short in the wiring.

Vigilance, as always, pays. Inspect your tools before starting a job. It's far easier—and safer—to catch and tape a small tear in a drill's power cord than to chance an injury.

A Lesson from Your Kids

As adults, we're supposed to exude maturity and responsibility and set an example for our children. We try to make sure they're fed, warm, and in bed on time. We don't always apply this same concern to ourselves, however, and this can be dangerous when we're working on our homes.

If you're cold, hungry, or tired, you could start making mistakes, so pay attention to your comfort level. Shaking hands, a growling stomach, and fluttering eyelids are signposts on the road telling you to pull over, put your tools down, have some lunch, and maybe catch a quick nap. We're viewed as a sleep-deprived nation, and there are plenty of accident statistics to affirm this view. You're not going to save any time or keep to a schedule if you have to redo some of your work later because it's faulty.

Speaking of Kids ...

Children also use electricity and need to use it safely. You, as a parent (or an adult friend), need to instruct them about the hazards of yanking electrical cords out of receptacles instead of holding the plug and pulling, using a hair dryer near water or with wet hands even if you have a GFCI in the bathroom, and sticking pens into receptacles to watch them melt. In addition to your always-welcome lecturing, a number of audiovisual helpers are available that could be shown at your children's school.



Positively Shocking

A flooded basement can be dangerous if the water comes into contact with any wiring, extension cords, or appliances. Don't enter your basement to start pumping the water out before the power is shut off. If you must go in, wear thick-soled rubber boots or call your local utility for assistance.



Ask an Electrician

A **double-insulated** tool doesn't have a ground pin in the plug. Instead, the wire conductor is surrounded by additional nonconductive material such as plastic. This does not guarantee against shock in the event of frayed wiring or damage to the tool. Metal casings also can be lined with nonconductive material.

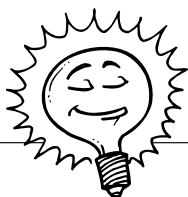

Bright Idea

A good fire-awareness project for your kids is to make a fire pail using a coffee can and baking soda. Send a self-addressed, stamped envelope to Arm and Hammer fire pail Brochures, P.O. Box 7468, Princeton, NJ 08543 for instructions and a label. Baking soda is perfect to use against small grease and electrical fires in the kitchen.

Some of these films include ...

- *I'm No Fool with Electricity*, by Disney Educational Productions. This film, according to its catalog description, somewhat implausibly shows Pinocchio and Geppetto exploring electrical safety both indoors and outdoors. Because he was made from wood, Pinocchio has the built-in advantage of being an insulator instead of an electrical conductor, at least as long as he remains dry.
 - *Electrical Safety from A to Zap*, from Perennial Education, Inc. In this film, a mouse shows a cat how to use electricity safely, their lack of opposable thumbs notwithstanding.
 - *Play It Safe from HECO*. This video features two children who learn safe practices around electricity. The film's big plus so far in our list of audiovisuals is the fact that it features human beings who actually *do* use electricity.
-
- *The Electric Dreams of Thomas Edison: A Guide to Indoor Electrical Safety/A Guide to Outdoor Electrical Safety*, produced by the Southern California Edison utility company. In this film, students defy all the rules of logic and physics by somehow communicating with the long-dead Thomas Edison, who informs them about grounding, insulators, and conductors. They also look for outdoor electrical hazards.
 - *Zap Rap*, from Pacific Learning Systems, Inc. Sure to appeal to the contemporary youngster, this film uses rap-style language to convey the wonders and dangers of electricity. As with most attempts to maintain students' interest through the use of entertainment as a teaching tool, you might give your kids a quiz to see if they learned anything at all about electricity other than a few tunes.
 - *Fire in the Kitchen*, from Film Communicators. This video is aimed at grades 7 through 12. There are no wooden puppets or rappin' electrons here. This video teaches kitchen safety, including proper use of a microwave oven.
 - *Our Invisible Friend—Electricity*. This 17-minute feature from Marcom Marketing Group also was made for grades 7 through 12. One has to wonder, of course, if any video made for seventh graders could be even remotely interesting to high school seniors.

- *Safety at Home: Electricity*, from AIMS Media. Geared for grades 9 through 12, a utility inspector shows careless use of electricity and the inevitable results. The inevitable results in grades 9 through 12 will be hooting and applause as actors are shocked and fried while doing things with appliances, receptacles, and plugs that a three-year-old wouldn't consider doing.

If my experience with audiovisual presentations when I was in school is still typical of students today (some things really don't change), I'd suggest that you take your children's electrical education into your own hands. Take them around the house, show them how the circuit breakers and GFCIs work, even show them how to properly insert and remove a plug from a receptacle. If they're old enough, turn the power off to a circuit, remove a switch or receptacle, and show them how it's wired. By the time they start getting bored, you'll have gotten the basics across.

Some Statistics

Mark Twain once said that there are three kinds of lies: lies, damn lies, and statistics. Trying to track down accurate figures about residential electrical fires produced quite a range of numbers. Everyone from the U.S. Consumer Product Safety Commission to various fire marshals across the country has a different figure to get the same point across: Misuse of electricity is a bad idea with sometimes incendiary results.

Based on my reading, the following figures are well inside the ballpark when it comes to fires caused by electrical problems:

- Approximately 45,000 to 50,000 fires each year occur in homes because of faulty wiring, appliances, and extension cords.
- The National Center for Health estimates that approximately 760 electrocutions take place from all causes each year including 310 occurrences involving consumer products.
- More than 3,000 children under the age of 10 are treated in emergency rooms each year after inserting objects into electrical receptacles. Another 3,000 are treated for injuries associated with extension cords.
- According to the CPSC, plugs and cords are involved in close to 20 percent of all residential electrical fires each year.
- Electrical fires kill hundreds of people in their homes every year, injure thousands more, and destroy hundreds of millions of dollars in property.
- December is the most dangerous month, electrically speaking, because of holiday lighting and portable-heater use.
- Older homes are more likely to have a fire than homes built in the last 20 years.

Some figures overlap, some are subject to various interpretations, and others, such as figures regarding electrocutions, may include industrial accidents. Sweeping all these distinctions aside, you don't want to be part of anyone's statistical table unless it's for happy, content homeowners with up-to-date electrical systems, cheerful children, and pets who do their business outside when nature calls.

Every holiday season, just about everyone's local news shows photos or a film clip of a family dispossessed and standing out in the cold because of a faulty space heater. It shouldn't happen to you if you follow the usual rules:

- Don't overload your circuits.
- Never replace a fuse or a circuit breaker with one of a greater amp rating.
- Don't run electrical cords under rugs or carpets.
- Carefully examine any wattage-hungry appliance, such as a portable heater, before using it, and then carefully monitor it while it's in use.



Bright Idea

Ontario Hydro (a Canadian power company) promotes the month of May as Electrical Safety Month, reminding people to keep a "safety first" attitude during outdoor activities. The company's tips include avoiding kite-flying near power lines, inspecting electric lawn mowers and power tools before each use, and avoiding mowing wet grass with an electric mower. Call the power company before you dig, it warns, so you don't hit any wires.

Electro Kindling

It's bad enough that a faulty electrical connection overheats inside a small appliance or device. What might even be worse is the fact that the wiring is surrounded by flammable materials, often plastic casings that have replaced the metal casings from years ago. Dr. Jesse Aronstein (of aluminum wire repute) came up with the term "electro kindling" to describe the material that ignites and burns after the failure of an electrical connection. A plastic toaster will be only too happy to burn if there's a wiring problem, while a metal one will just hang tight until you unplug it or until the wiring fries to a crisp. There have even been reports of multiple-outlet strips, icemakers, and plastic thermostats failing and subsequently igniting.

Such is the price of a society that embraces plastic in all its forms. The possibility of electro kindling should reinforce the practice of unplugging your small appliances when they're not in use.

New Service Doesn't Let You Off the Hook

I'm a big believer in new electrical services, but that doesn't mean you can ignore them completely, especially if they're tied into older, existing wiring. Breakers should trip if a circuit is overloaded, and GFCIs should shut down in the event of a ground fault, but there's always the chance you have a piece of defective equipment. Unlikely? Sure, but it's certainly possible.

Test your GFCIs monthly and pay attention to outlet and switch cover plates that seem too warm to the touch. If you ever smell anything burning around a receptacle, and it isn't an individual appliance or load, shut down the circuit immediately and call an electrician. It's worth the price of a service call for your peace of mind.

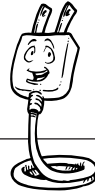

Electrical Elaboration

According to CFRA News Radio's Web site, a fire at the home of Dallas Cowboys quarterback Troy Aikman in March 1998 was attributed to faulty wiring. This wouldn't be an exceptional news item except for the fact that the \$3.2 million home, which took more than two years to build, was brand new! The three-alarm fire at the Plano, Texas, home caused almost \$200,000 in damages to the attic and the garage. It took 50 firefighters to extinguish the fire in the house where Aikman, who was away at the time, had lived for a total of three weeks.

More Information

For more information about electrical safety, contact one of the following agencies for printed material:

National Electrical Safety Foundation

1300 North 17th St., Suite 1847

Rosslyn, VA 22209

Phone: 703-841-3211

Fax: 703-841-3311

Send a self-addressed, business-size envelope with 55¢ postage for a copy of the *Home Electrical Safety Check* booklet.

The United States Fire Administration
Office of Fire Management Programs
16825 South Seton Ave.
Emmitsburg, MD 21727

The Least You Need to Know

- Preventing electrical shocks and electrocution should be a top priority with any electrical system.
- The most common causes of shock are bad wiring practices and human error.
- The number-one safety rule when working on an electrical system is to shut the power off.
- Children should be educated about electricity and how to use it safely.



Call Me Sparky

In This Chapter

- ▶ Thinking like an electrician
- ▶ Getting a permit
- ▶ Understanding your inspector's viewpoint
- ▶ The tools you'll need
- ▶ Picking your suppliers

Wiring is a nice, logical process. You want to get power from point A to point B in the most efficient way possible. Running wire or “roping” a house is mostly a matter of drilling access holes through the house’s framing (the wall studs, plates, and floor joist) and pulling electrical cable through those holes. *How* you carry out this nice, logical process is another matter altogether.

Like just any task in life, you can do your own electrical work the hard way or the easy way. The hard way means tearing open more walls than necessary, undoing and then redoing part of the job due to poor planning, and trying to drill holes, cut wire, and strip insulation with cheap tools. The easy way calls for planning and economizing your moves and using good tools to give you a better job and to move you through it faster. You won’t be as fast as an experienced electrician, but you’ll have the satisfaction of doing your own work and doing it well.

If you’re going to be your own electrician, you need to take your role as seriously as a professional would. This means presenting any required plans to your building department when you take out a permit, knowing the code issues, using the right tools, and

finding suitable suppliers for your materials and fixtures. You don't need to invest in the same level of equipment as an electrical contractor does. After all, you're not going to be making your living at this. You can, however, become a talented amateur whose work can be respected, even by a professional!

An Electrician's Mindset

An electrical contractor has the following goals in mind when bidding, planning, and actually doing a job:

- The job must meet the customer's requirements.
- The work must be safe, meet code, pass inspection, and be finished in a timely manner.
- The final result should be a satisfied customer and a profit for the contractor.

Your goals as a do-it-yourselfer shouldn't be any different. You want your work to be of satisfactory quality so you can live comfortably with it rather than going crazy every time you look at a crooked light switch or receptacle. It goes without saying that your work must pass inspection, but you also want to get it finished sometime before you reach retirement age. Money-wise, you want to realize a savings from doing your own work. This can be measured in different ways. Some people keep an exact accounting of their hours and assign an hourly rate to the job versus an electrician's labor bid. Others see it as using their off-hours productively, and anything they save is pure profit. However you measure your savings, you will have faced some challenges and learned from them, and you can't put a dollar value on that.

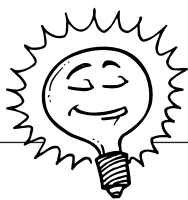

Bright Idea

Arrange to look at a house under construction so you can examine the electrical work, especially the service panel. This will give you a better idea of the minimum standards you'll have to meet when you do your own work.

By now, you'll have drawn up a plan, calculated the loads, and gotten your permits. A plan on paper will show you where to locate a receptacle or a light fixture, but it won't show you how to do so. For example, will you ...

- Run your cable through the attic and drop it down between the wall studs?
- Consider using the basement or a crawl space for access?
- Use wire molding and run it along the surface of your baseboards?
- Remove some of the wood trim and cut into the walls behind it to avoid patching more noticeable sections of the walls?

A half-hour of forethought and planning can save you hours of patching. If there's more than one solution to the job, look at them all and decide on the best approach.

Think Before You Drill

Drilling an unnecessary hole or two through a wall stud or a floor joist isn't a big deal. Visitors will never see it, and you're not weakening your house's framing. This won't help you get the job done any faster, however, especially if you drill a whole series of holes in the wrong places. Drilling the wrong hole in plaster or drywall is another matter because it requires a repair. In the worst-case scenario, let's say you cut a four-inch-diameter hole in the ceiling with a *hole saw* only to discover it was in the wrong location. You would have to ...

- Patch in new drywall or plaster.
- Coat the patch with finish plaster or drywall compound until it's smooth. (In the case of a textured surface, the texturing would have to be matched.)
- Prime and paint the patch.
- Possibly paint the entire ceiling to match the patched area.

What if you're not sure where you want to locate a light fixture? Attach some blue painter's masking tape (this type doesn't dry out as quickly as regular masking tape) to the proposed location and leave it up for a day or two. Apply the tape in roughly the same shape as the fixture. If it's a hanging fixture, also attach a string the same length as the chain or light cord. You might decide you don't want hanging lights, or you might want to relocate them. When you're satisfied you've found the right location, you can start cutting into the ceiling.

Minimum Damage, Minimum Repairs

Hole saws and other tools of the trade do more than make pretty holes for your electrical work. They also keep damage and subsequent repairs to a minimum. This is especially true when you're cutting through plaster and lath. Lath is the wood or metal backing that acts as a form for wet plaster. The plaster is forced into the lath where it eventually dries into a wall or ceiling. It's almost impossible to cut a clean hole through lath using hand tools. A hole saw or



Ask an Electrician

A **hole saw** is a circular saw attachment for electric drills. It is used to cut through walls and ceilings instead of using a hand tool, usually a **small keyhole saw**. A hole saw renders a smooth, neat opening for a round electrical box used for most light fixtures. It's important to keep the hole saw straight when in use so it doesn't bind and cause the drill to turn and possibly slip.

a reciprocating saw will do the job quickly and cleanly. Believe me, you'll never catch an electrician using hand tools when a power tool is the better choice.

You might think you have limited use for a hole saw, and you might not want to spend the money on one, but there's another way to look at it. A four-inch hole saw costs around \$20. If you have to install five light fixtures, the hole saw is costing you \$4 a light. It's also greatly reducing your labor time, and you can avoid the frustration of trying to cut a clean circle with hand tools. Besides, you can always find a future use for it, especially if you have more remodeling projects in mind.

Permits

I'm not going to pretend that a permit is taken out for every electrical job, even if the local building regulations call for it. It's tough to justify the time and expense to obtain a permit when you're only adding a single receptacle to a circuit that can easily support the addition. Nevertheless, I would be remiss as an author if I ever advocated anything less than playing by the rules, especially given the possibility of harm and damage from wayward electrical work. As a case in point, our own electrician recently was telling me about some receptacles added in a residence—by another electrician—without a permit, and none of them were grounded correctly.

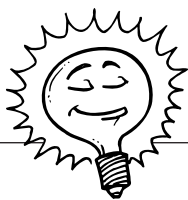

Bright Idea

You can always discuss your plans with your local building department before you take out a permit. It might point out any deficiencies and guide you through the permit process. Your application is more likely to go through with fewer hitches.

You need a permit any time you alter the existing system. This includes ...

- Adding additional receptacles or fixtures.
- Adding new circuits.
- Installing a new service or a subpanel.

You usually do not need permits for repairs or updates that do not extend the existing system. This includes ...

- Replacing existing lights with new fixtures.
- Replacing broken switches or receptacles.
- Replacing defective circuit breakers.

Always consult your local code to confirm whether you need to take out a permit before you do your work.

Keeping the Inspector in Mind

An electrician has some built-in advantages when dealing with an electrical inspector. He or she can speak knowledgeably about code issues and can justify the manner in which the work is being carried out if there are any questions or objections. It's

assumed that an electrician will be basically competent. As a do-it-yourselfer, your work should be neater, cleaner, and on the conservative side. You don't want to be pushing the electrical-code creativity envelope.

The Code Calls the Shots

This bears repeating: Your local code lays out the rules you must follow when doing electrical work. It might seem very logical to you, for example, to add a bathroom receptacle by extending your underused bedroom circuit. After all, there's a bedroom outlet right on the other side of the bathroom wall. What could be simpler than running a few wires and calling it good? Simpler or not, the code states the receptacles in bathrooms must be dedicated to the bathroom, be GFCI protected, and have a minimum ampacity of 15 amps. Safety, not simplicity, is the main concern of the code.

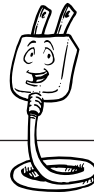

Electrical Elaboration

Remember, the inspector has the final word, whether you're a do-it-yourselfer or a been-in-the-business-forever electrician. This doesn't mean an inspector can't make a wrong call, but the call must be changed in your favor, or you must resolve the problem as the inspector sees it. Some inspectors have reputations for simply being disputatious; others are more reasonable. In the worst cases, disputes over work are taken to an inspector's supervisor.

Insurance Issues

If safety and legality aren't compelling enough reasons for you to follow your local electrical code and have your work inspected, a chat with your insurance agent might be more convincing. Any damage to your house as the result of faulty, uninspected electrical work (no matter whether it's done by you or an electrician) probably will not be covered by your insurance company (read your policy carefully). This can range from something relatively simple such as cleaning up after smoke damage to losing your entire home in a fire.

Let this sink in for a moment. You could lose a \$200,000 house if a kitchen circuit isn't installed properly, becomes overloaded, and starts a fire in your walls—all due to the lack of a permit and inspection. Why take the chance? Some electricians might tell you not to bother with a permit for some jobs, but you have to wonder why a

contractor would put his business reputation or even license on the line like that. Gambling is more fun in Las Vegas. At least you can get a cheap steak dinner and 24-hour lounge acts out of it.

Tools of the Trade

Neanderthals first used stone tools around 70,000 B.C.E., and life has never been the same since. What started out with a guy named Og making a few simple carving and cutting implements has grown into a multibillion-dollar manufacturing behemoth. From fine Japanese woodworking saws to portable cement mixers, there isn't a single tool we cannot buy or rent. If you walk into any Home Depot or other large home-improvement chain store, you'll find an absolute cornucopia of both hand and power tools.

Every remodeler needs some of both. The notion that the builders of yesteryear felt greater personal accomplishment because they did everything by hand is an absolute myth. Workers in the trades grabbed just about every labor-saving power tool they could as they were invented.

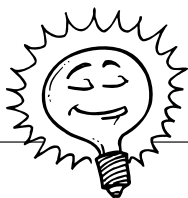

Bright Idea

Yard and estate sales can be good sources for used tools. Look for tools in the best condition, especially hand tools. The cutting edges should be sharp, and the ends of the screwdriver blades should not be worn or rounded. Turn on electrical tools and look inside the vented section. You don't want to see any excessive sparking or smell a "burning" motor.

You don't need the very best tools. Some professionals even shy away from top-of-the-line products because they have more opportunities to damage them on a job site or to lose them, sometimes through theft, as they move around to different locations. On some very large jobs, contractor bids might include the price of new tools. Ironically, a homeowner, who will use tools far less often than a professional, probably would get more use out of expensive, top-quality tools.

Electrical work calls for some specialized tools as well as some multiple-purpose power tools.

Hand Tools

You'll already be familiar with some of these tools; others are limited to the electrical trade. These tools will cut, strip, and twist wires and will secure electrical boxes, light fixtures, switches, and receptacles. You *could* strip away insulation with a pocketknife and cut wire by bending it back and forth until it breaks, but you'll end up with sloppy results and damaged cable.

Good cutting and stripping tools prevent wires and insulation from getting nicked and enable you to work with wire in tight areas such as small boxes. The following tables list the basic hand tools for electrical work and some more specialized tools, too.

Basic Hand Tools for Electrical Work

Tool	Purpose
Claw hammer	Securing boxes to studs and joist
Long-nose pliers	Bending wires
Lineman's pliers	Pulling wires and cutting
Diagonal pliers	Cutting in tight spaces
Slotted screwdriver	Securing switches and receptacles
Phillips screwdriver	Securing switches and receptacles
25-inch measuring tape	Setting box heights and so on
Keyhole saw	Cutting through walls and ceilings
Hacksaw	Cutting flexible, armored cable
Wire stripper	Stripping wire insulation
Cable stripper	Stripping cable insulation
Flashlight	Working in dark spaces
Ladders	Accessing overhead work
Voltage tester	Testing for current
Receptacle analyzer	Testing for electrical faults
Continuity tester	Testing for interruptions in the path of a current

Specialized Hand Tools for Electrical Work

Tool	Purpose
Fish tape	Pulling wires through enclosed areas
Conduit bender	Bending metal conduit around corners
Level	Ensuring that equipment is installed straight and true
Masonry chisels	Working on exterior installations
Adjustable wrench	Tightening rigid conduit connectors

Your task will determine the tools you'll need.

Power Tools

During the dawn of electrification at the end of the nineteenth century, electric tools had yet to be invented. Knob-and-tube wiring passed through wall plates (the horizontal 2×4s at the bottom of a wall) but ran along the surface of the wall studs, so electricians had little drilling to do. These days, it all passes through studs, plates, and joist, and no one in their right mind would hand-drill the necessary holes. The electric drill is probably the most ubiquitous power tool around.

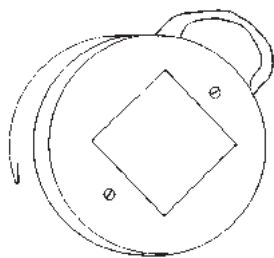

fish tape

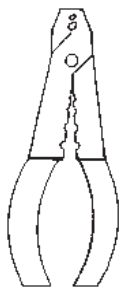

multi-purpose wire stripper



continuity tester



screwdrivers



pliers

These are some of the hand tools you'll need for electrical work.

(Photos courtesy of Craftsman)



Positively Shocking

Cutting tools must be kept sharp; otherwise they can slip and injure you or damage the work. Screwdrivers also can slip and should be examined for dulled or rounded blade ends. Pliers can turn smooth and can lose their gripping capability. Any tool that cannot be repaired should be replaced.

Drills are manufactured according to chuck size. The chuck holds the drill bit or another attachment such as a grinding wheel or a buffer pad. The larger the chuck, the bigger the drill motor (because more power is required to drive larger drill bits and attachments). A manufacturer's usual line of drills includes $\frac{1}{4}$ -inch, $\frac{3}{8}$ -inch, and $\frac{1}{2}$ -inch models.

Drills come in both corded and cordless models. A cordless model runs on a rechargeable battery. Cordless tools are really convenient. The drawback, of course, is battery life. The tougher the task, such as drilling through wood joist, the more demand on the battery and the shorter its work life before needing a charge. A high-end model such as a Makita $\frac{1}{2}$ -inch, 18-volt cordless will hold up longer under more demanding drilling, but it isn't cheap (around \$245). For repetitive, serious drilling, a corded model often is the best choice.

A cordless drill usually costs more than a corded model of equal size. Sales and close-outs can narrow the gap. Power is the key here, so stick to at least a 12-volt model. Also compare charging times for the batteries (the shorter the better).

A decent 1/2-inch drill will get you through most electrical drilling chores and just about any other job around the house. It will last for years and years doing occasional residential work without breaking your remodeling budget. Prices for an acceptable 1/2-inch electric drill start at around \$70 and up. You'll find a few other power tools and accessories to be useful as well including ...

- A reciprocating saw for sawing large holes in walls and ceilings.
- A circular saw for framing work.
- 12/2 extension cords.

Extension cords are manufactured according to wire gauge, just like electrical cable. A 12/2 cord is made from 12-gauge wire and contains hot, neutral, and grounding conductors.

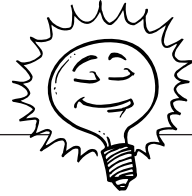

Bright Idea

Buy a second battery along with your cordless tool if you expect to be using it extensively. This way, you always have a battery charged and ready to go while the other battery is being used. Professionals almost always have two batteries on hand and rotate them.

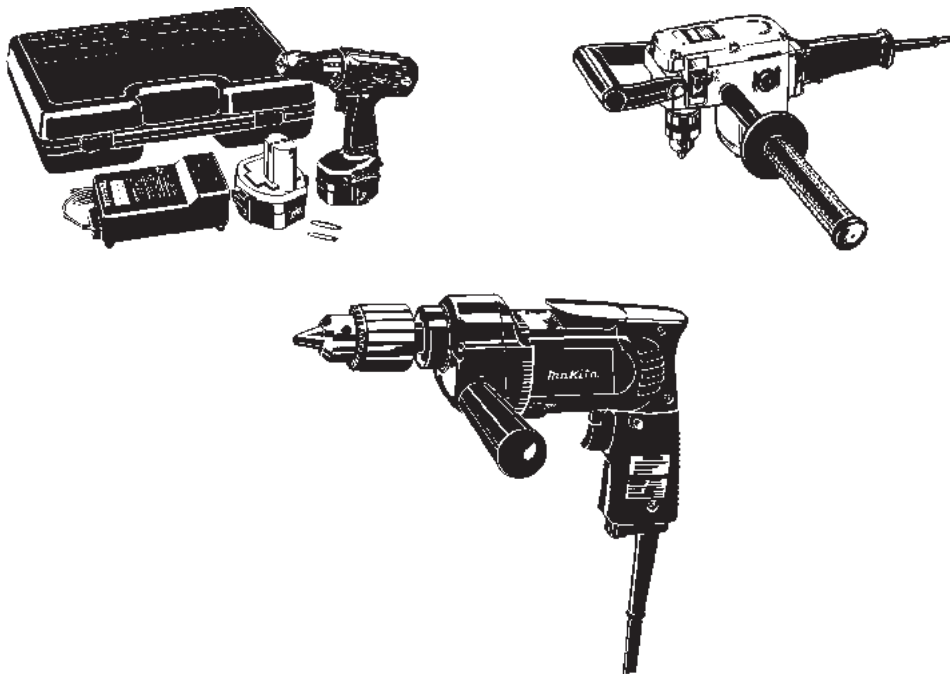

Corded and cordless drills.

(Images courtesy of Makita USA, Inc.)

Reciprocating saws.

(Photos courtesy of Makita USA, Inc.)



Care and Feeding of Power Tools

Power tools are great timesavers and are more fun to use than hand tools. These tools won't be fun for long, however, if they're misused and abused. Be sure to avoid the following:

- Lifting the tool by pulling on the power cord instead of the handle or body of the tool
- Dropping the tool, especially from the second floor to the first
- Applying too much pressure while using the tool and ignoring warning signs such as the blade or drill bit slowing down and straining or the motor giving off a burning smell

- Ignoring damaged cords
- Leaving the tool out in the rain

Tools don't ask for much. They're like huskies and dogsleds. If you treat huskies well and keep them fed, they'll pull your sled until they drop. A power tool will keep going and going if you take care of it. I've run across homeowners with 40-year-old electric drills that still run like the day they came out of the box.

Taking care of your tools also will protect you. A frayed cord can lead to an electrical short, which is not good for your health. A dull blade or drill bit can cause the tool to slip and cut you instead of the wood you're aiming at.

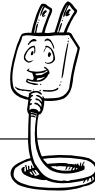

Electrical Elaboration

It's best to recharge your drill batteries as soon as the drill begins to slow down. It used to be recommended that the battery be completely run down to get a full charge, but this no longer is the case and in fact can ruin the batteries.

Bits

Drill bits come in every shape and size for all types of jobs, from drilling through masonry to fine craftwork. The most common bits most of us have seen are twist bits that are sold both individually and in sets based on gradation. Twist bits are fine for small holes, but they're not much use in electrical work except for running small, low-voltage wires.

Electricians run more than one cable through a hole whenever possible, and larger holes (one inch in diameter) are drilled with another type of drill bit. The following are the most common bits for drilling larger holes:

- A spade bit
- An auger bit
- A power bore bit

When running a single cable through a wall stud or joist, a $\frac{5}{8}$ -inch hole usually is drilled.

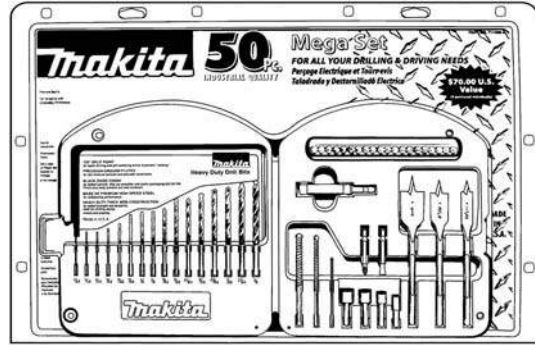
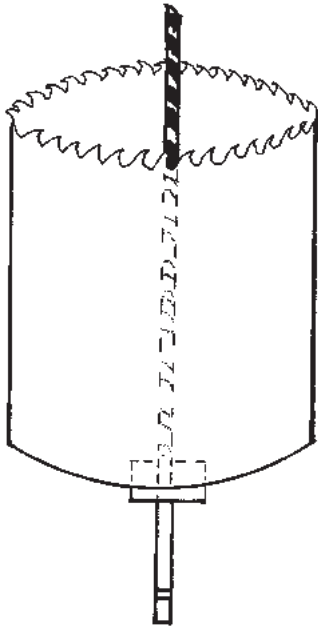

A drill bit and hole saw for everything.

(Images courtesy of Makita USA, Inc.)

Rent or Buy?

Tools might come with some of the same specifications, but one 1/2-inch drill isn't necessarily the same as the next. One of the main differences is the size of the motor. Professional, heavy-duty models have large motors and can reduce your drilling time through wood and masonry. Hand tools have their differences as well, usually in the quality of the metal components and the sharpness of the cutting edges. Price is a good determinant here, and you really do get what you pay for. That's why those 99¢ screwdrivers lose their square edge quickly.

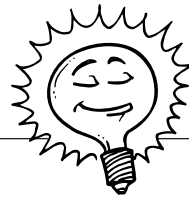

Bright Idea

Be sure to check online prices for power tools. You'll at least get some idea of whether a local price is reasonable. Tool prices generally are pretty competitive, but check a few different sources before making your purchase.

If your framework is exposed and you're ready to do a lot of drilling at once, you might be better off renting a drill with a large motor. An electrician will use a heavy-duty drill regularly and can justify the expense of owning one. The larger the motor, the weightier the drill, so these tools aren't appropriate for all drilling jobs unless you're on steroids. As a cost comparison, a Makita 7.5 amp, 1/2-inch angle drill (a large right-angle drill) runs about \$290. Local rental prices vary, but I'd be surprised if it cost more than \$20 or so a day to rent one of these. A right-angle drill is convenient for drilling in tight spaces.

Before you rent a tool, handle it and get a feel for it. A heavy tool can be uncomfortable to hold for an extended period of time. You might be better off with a smaller drill that you can handle more safely. When I had nothing else available, I drilled through old, hardened floor joist with a 3/8-inch drill without the sharpest of drill bits, and I still got the job done (not that I recommend this approach—it took time).

UL-Approved Parts for You

It would be unusual to run across an electrical component that isn't UL (Underwriters Laboratories) approved, but always check for this tag or stamp of approval on anything you buy, whether it's a flashlight, power tool, or electrical device. A UL listing is your assurance that the product has been tested for safety. Receptacles, light switches, light fixtures, and appliances all should have UL approval.

Keep in mind that UL approval doesn't imply longevity or ease of installation. A cheaper, lower-end product will never be the equivalent of a more expensive product.

Home-Improvement Stores vs. Electrical Wholesalers

Electricians usually do their shopping with suppliers whose stock and trade are electrical components. Large commercial companies always shop at these establishments. They don't share their space with paint, kitchen cabinets, or coupon specials. They also don't operate quite the same as a retail establishment. This means ...

- Don't expect them to explain how to do your wiring or use the tools.
- Very little will be on display, so you'll need to have a clear idea of what you want when you go in.
- If a store is wholesale only, it might sell only to contractors.



Electrical Elaboration

I was in one Seattle electrical wholesaler's store some years ago when a lot of electricians began streaming in on their lunch hour. A homeowner was next in line, and he came in to buy an entire electrical service. He wanted to know what he needed, explaining that he had called earlier and was told they would "fix him right up." The clerk was not amused as he peppered the customer with questions about the service size he required, the type of meter, whether the cable was coming in overhead or buried, and so on. Answers were not forthcoming, and the line of electricians, who knew what they wanted, just kept growing

The advantage of shopping at a wholesale supplier used to be the range of supplies and devices available, but in recent years, the large homeowner-oriented building-supply stores such as Home Base and Home Depot have narrowed this gap in the residential categories. A trip to our local Home Base found Square D, Cutler-Hammer, and Westinghouse service panels available as well as a huge variety of boxes, conduit, cable, connectors—you name it. These stores are geared toward do-it-yourselfers who need to see the components and fixtures instead of trying to order them blind at a wholesaler. They also order merchandise by the trainload and usually have competitive prices.

The Least You Need to Know

- As a do-it-yourselfer, you want to handle your electrical work at least as neatly and as safely as a professional electrician.
- Careful planning always saves cleanup and patch-up time.
- The very best tools might be out of your budget range, but the cheapest will cost you more. Find a happy medium when you go tool shopping.
- It's easier to take care of your tools than to replace them.

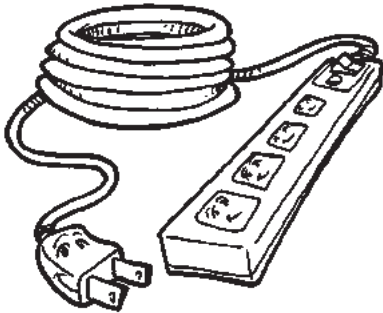

Extension Cords and Multiple Strips

In This Chapter

- ▶ Differences among extension cords
- ▶ Choosing the right cord
- ▶ Avoiding overloads and problems
- ▶ Protection from surge suppressors

During large construction and remodeling jobs, it's common to see extension cords snaking throughout the work site. In fact, the condition of individual extension cords is a common safety violation on these sites. Cracked insulation, loose plugs, and broken or missing grounding pins are the most common problems.

A safety inspector isn't going to ring your doorbell and check out your use of extension cords or multiple-outlet strips. Despite their common use, many people don't understand extension cord protocol. Something as simple as the placement of an extension-cord can make it a safety hazard. Some manufacturers don't help much, either. Thousands of potentially defective cords have been recalled in recent years.

Surge suppressors offer more than just a few extra outlets at the end of an electrical cord. They can protect the valuable electronic equipment (such as computers, sound systems, and fax machines) that we increasingly can't live without from voltage jumps in our electrical systems. Think of a surge suppressor as the sacrificial lamb that takes the hit from a voltage spike so your computer can live to frustrate you another day. Unfortunately, a suppressor cannot work without a grounding conductor, so if you have an old two-wire system, you're out of luck.

Every manufacturer of this protective equipment seems to believe its suppressors could soak up a bolt of lightning thrown by Thor himself. A little information and a few figures will help you choose the best suppressor for your home needs.

Extension-Cord Protocol

Think of an extension cord as a portable, impermanent form of wiring. It's subject to the same laws and limitations as any other electrical conductor, which means it can be overloaded, it can short out, and its insulation can melt. On top of that, they're easy to trip over when they're left lying around a work site.

Extension cords are handy and necessary, but they need to be used carefully and inspected before each job. According to the Consumer Product Safety Commission ...

- More than 3,000 residential fires each year are attributed to extension cords. Most of the problems are the result of short circuits, excessive loads, and misuse of the cords.
- Hospital emergency rooms treat more than 2,000 injuries each year associated with extension cords. These injuries include fractures, lacerations, and sprains from tripping over the cords. About half of the injuries to children are caused by electrical burns to the mouth.
- Tens of millions of dollars in fire damage occur yearly as the result of misuse of extension cords.

You might never look at an extension cord in the same way again!

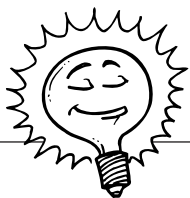

Bright Idea

Unplug and put cords away after each use. This happens on most commercial job sites as part of the daily cleanup before everyone goes home. It's a good practice for a do-it-yourselfer as well.

What the NEC Says

Extension cords aren't permanent wiring, so the National Electrical Code doesn't apply to them per se, but it does lay out some guidelines. The NEC would prefer that you use a close-by receptacle, but that's a little unrealistic if you're running an electric lawnmower, for example. The code recognizes that extension cords are meant only for temporary use for portable loads that aren't fixed to one specific location.

What about a table lamp and clock radio by your bedside connected to a small-gauge extension cord because the only receptacle on the wall is beyond the length of their appliance cords? The NEC would like you to install a new receptacle, but sometimes this isn't practical. If you're renting, you would have to

convince your landlord/landlady to accept this additional expense. For such a small load, the use of an extension cord on a regular basis isn't a big deal. Problems occur, however, when extension cords are used to run large loads on a more or less permanent basis. Small extension cords become a bigger problem when they are installed under a rug or are in any way covered over so they retain heat.

One Size Doesn't Fit All

Extension cords are measured by their wire gauge size just like the wires running inside your walls. Their ampacity rating uses the same *American Wire Gauge (AWG)* standards: the smaller the number, the thicker the wire (which means it can carry a larger current because it offers less resistance). This is especially important with longer cords because a current loses some voltage as it travels over a conductor, and this can affect the performance of a device (such as a power tool) on the other end. When the voltage drops, any electrical equipment on the cord will pull more current to compensate for the lost voltage. This generates more heat, which causes damage to the tool. The longer the conductor, the greater the voltage drop. Contractors usually use a 12/2 extension cord to run their tools, and you should, too.

Typically, extension cords are available in 10, 12, 14, 16, and 18 gauges. An 18-gauge cord is the size normally used for very small loads such as lamps or clock radios.

The following table shows typical extension-cord lengths and gauge combinations.



Positively Shocking

You don't want to overload an extension cord by plugging in an electrical load too large for its ampacity. One sure sign is a cord that's warm or hot to the touch. If this happens, turn the devices off or use a larger cord. And *never* use an extension cord to run a portable heater!



Ask an Electrician

AWG stands for **American Wire Gauge**. You can always use a larger-gauge wire than a load calls for, but you cannot safely use a smaller gauge. You can't go wrong with a 12-gauge extension cord for your remodeling work.

Extension Cord Gauges (AWG), Lengths, and Amp Ratings

Amp Rating	Cord Length		
	50 Foot	100 Foot	200 Foot
8 to 10 amps	18 AWG	14 AWG	12 AWG
10 to 12 amps	16	14	10
12 to 14 amps	16	12	10
14 to 16 amps	16	12	10
16 to 18 amps	14	12	8

When Cords Go Bad

In the 1960s, the first recalls of defective or assumed-defective automobiles began, and we've been recalling consumer products ever since. Surprisingly, there have been a number of extension-cord recalls, although they don't get quite the same publicity as, say, recalling the family minivan because the wheels have a tendency to fall off. The following is a list of recent recalls, courtesy of the Consumer Product Safety Commission:

- Approximately 230,000 extension cords manufactured in China and distributed by a Texas firm were recalled due to undersized wires and improper plugs, according to a September 20, 1994, announcement.
- In a May 29, 1997, press release, the General Cable Corp. announced the recall of 2,700 outdoor extension cords sold under the Carol and Ace brand names due to an exposed wire near the receptacle. No injuries had been reported from the use of these cords.
- A Miami, Florida, firm recalled almost 6,600 extension cords and power strips in 1998 due to undersized wires that could not carry the advertised load, improperly polarized plugs, and no overcurrent protection in the surge protectors.
- A February 24, 1999, press release warned consumers about two *million* faulty extension cords, power strips, and surge protectors involved in 25 recalls since 1994. An ongoing investigation started in 1997 found that most of the faulty cords were made in China, were sold at discount stores, and in some cases, had counterfeit UL certification labels.

This doesn't exactly inspire confidence, but it's useful because it provides the motivation to inspect and check your extension cords on a regular basis. On large construction sites, monthly testing of extension cords for grounding is mandatory, as is recording the test results. Cords that pass inspection are marked with a piece of colored tape. (The color changes monthly.)

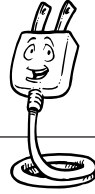

Electrical Elaboration

One of the main problems with extension-cord use in a residence is forgetting that you're using cords! I've been on a number of jobs where extension cords had been tacked up in basements for years to run lights or power tools. The owner might have intended a temporary installation. If you've purchased an old house, you might find extension cords that have blended into the background. Remove them!

Know the Rules

Extension cords come with warnings and usage guidelines just like every other consumer product. Some of the best advice comes from fire departments and the Consumer Product Safety Council, both of which have experience with the injuries and destruction caused by misuse of extension cords and power strips. Here's a list of extension cord do's and don'ts:

- Use extension cords for temporary use only.
- Unplug extension cords when they're not in use.
- Only use cords having gauges that are properly matched to the load and the current to be drawn.
- Only use cords outside that are specifically marked for this type of use.
- Only use polarized receptacles with polarized cords.
- Never remove the grounding prong from the plug of an extension cord to fit it into an ungrounded receptacle.
- Regularly inspect your cords for damage.
- Never splice a damaged extension cord or one cord to another.
- Do not run cords across or through wet areas or puddles.
- Hang cords high off the floor to avoid tripping hazards on work sites. Don't allow cords to hang from counter- or tabletops where children can pull on them.
- Cover any unused sections of the cord's outlet end with safety caps to keep children from inserting objects.
- Replace damaged or worn cords.
- Always stretch out the cord, and never cover it with rugs, carpets, clothing, or heavy objects. Cords can build up heat if they are used when coiled or looped.

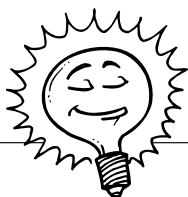

Bright Idea

Keep your extension cords free of kinks and knots. The easiest way to straighten out longer cords is to hang them out a second- or third-story window and let them untwist.

- Extension cords are temporary wiring. Don't attach them to walls or woodwork with staples or nails that can damage the cord and present a fire hazard.
- Don't plug extension cords together. Instead, use a single cord long enough to do the job on its own.
- Buy cords that have been tested by an approved testing lab such as Underwriters Laboratory (UL) or Electrical Testing Laboratories (ETL).

Homemade Cords

Once in a while, I run across a home in which a contractor used extension cords made from nonmetallic cable with a plug spliced on to one end and a pair of receptacles in a box on the other. You would never see

this on a large commercial job because it would be considered a safety hazard. The more creative guys attach the receptacles to a wood stand with a plywood base so a work light can be mounted. I don't see any clear advantage to messing around with made-on-the-job cords like this when an approved 100-foot, 12/2 extension cord can be purchased for a modest amount of money and will last for years.



Ask an Electrician

EMI and **RFI** stand for **electromagnetic interference** and **radio frequency interference**, respectively. This is "noise" on the power line that can interfere with sensitive electronic equipment. The word **attenuate** refers to a reduction in power or energy (or, in surge suppressors, noise).

Multiple-Outlet Devices

If you've got a computer and its peripherals (a printer, scanner, and ZIP drive), you probably have a power strip of some kind unless you specifically wire a room of your house as you would an office and give yourself plenty of receptacles. Power strips usually are rectangular-shaped with four or more individual outlets and a built-in circuit breaker.

Most power strips in hardware and discount stores are an all-purpose type and are not appropriate for computer use. Leviton, for example, makes computer-grade strips that, according to the catalog, feature "EMI/RFI noise attenuation for microprocessor-driven electronic equipment." They also provide surge suppression.



A Leviton power strip.

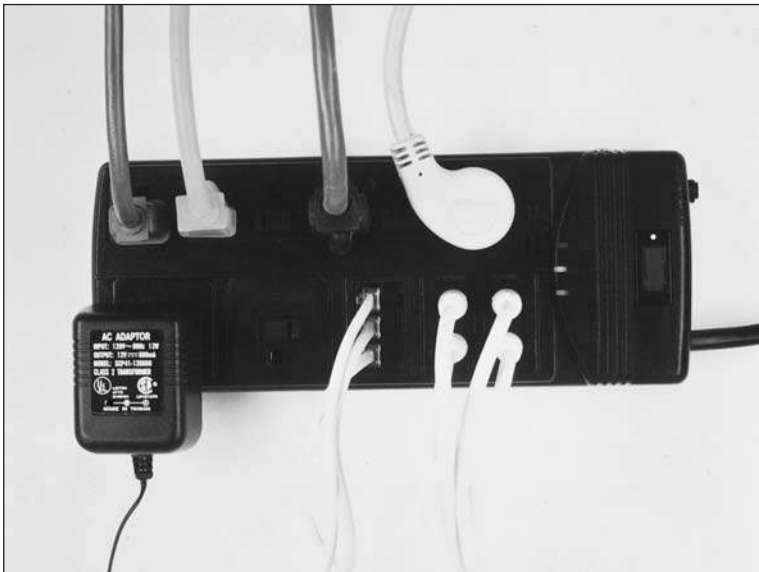

A Leviton suppression strip.

You can add receptacles by using outlet box lampholders. These typically are porcelain light fixtures with pull chains to control the lights (instead of a switch). Some of these lampholders, often found in unfinished spaces in a house, come with built-in outlets. These *really* are meant as a temporary power source, not for running multiple power tools. Remember, as a lighting circuit, it's most likely running on only 15 amps. Note that in a crawl space, the receptacle on a porcelain lampholder must be GFCI-protected.

A Leviton lampholder.

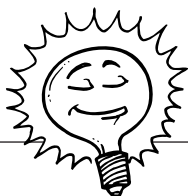

Bright Idea

Consider using a plug-in GFCI outlet that can protect old two-wire systems. These units simply plug into existing receptacles for standard ground-fault protection and can easily be removed and installed in another receptacle as needed.

Surge-Suppression Devices

Electricity is like human relationships: It has its peaks, its low points, and a lot of time in between when it just muddles through without causing much excitement. Left to its own devices, it probably would muddle through day in and day out, but we (and a lightning storm or two) interfere and cause surges and spikes. What are they? Simply put, they are increases, usually sudden, in electrical voltage.

Surges differ from spikes in part by how they occur. Surges can result from ...

- The energy demand when a large appliance is first turned on.

- Routine maintenance and switching by your utility company.
- The rush of current to your house after power that was cut off is turned on again.

Spikes, on the other hand, most often are caused by lightning or by cars running into power poles. Spikes can send as much as 6,000 volts down your line.

A surge is apparent when you turn on a garbage disposer or a laundry-room appliance. The appliance requires a surge of power to get rolling. This is the same principle behind moving a stationary body: The initial force or power required is greater than the amount needed to sustain movement. The first few pushes you give your kids on a swing require more energy than later ones after momentum has been established.

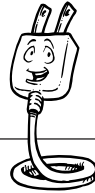

Electrical Elaboration

Another problem, the opposite of a surge or a spike, is a **sag**. Sags are brief decreases in voltage level, and they usually result from too much demand for power on the electrical system. This sudden loss can cause computer crashes and possible loss or corruption of data. A sag is the same as undervoltage. Brownouts and blackouts are huge undervoltage situations.

Both surges and spikes are fairly short in duration, but they differ in their voltage consequences. A spike often brings thousands of volts with it but only lasts for a few microseconds (millionths of seconds). A surge lasts longer but has much lower voltage as a rule. Your electrical system isn't quick enough to protect your relatively fragile electronic equipment from surges and spikes, but a surge suppressor will do the trick.

What Do They Do?

In addition to making surge-suppressor salespeople happy when they sell them, a surge suppressor protects all the electronic equipment we seem to have around our homes these days, from computers to VCRs. A suppressor, which typically goes between your electronic equipment and a receptacle, detects a voltage increase and prevents it from continuing into the equipment.

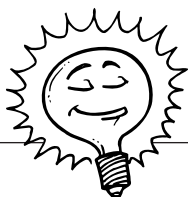

Bright Idea

You can't predict when a spike will occur, but a lightning storm rolling in serves as a warning. If you don't need to use your electronic equipment at the time, simply unplug it until the storm is over. If you're leaving town for an extended trip, unplug everything electronic and you won't have to worry about it.



Positively Shocking

A surge suppressor can only go so far in protecting your equipment. It won't stop a lightning strike to your power lines, but a lightning rod might. Another legacy of Ben Franklin, a lightning rod redirects lightning away from your house and into the ground.

What should you consider protecting? Anything with a microchip such as ...

- Computers.
- Televisions, VCRs, and stereos.
- Telephones and answering machines.
- Microwave ovens.

Why telephones? Phone lines and cable lines run in close proximity to power lines. An electrical surge could travel down the phone or TV line instead of the power line. Not only your phones but also your computer could be damaged if it has a modem and is connected to your phone line.

Computers Aren't Very Tough

We can replace a television or an answering machine quite easily, but it's not so easy to retrieve lost data on a hard drive after a surge or spike hits the old PC. The worst-case scenarios, at least as presented by various surge-suppressor manufacturers, include ...

- Losing any data in memory.
- Possible damage to the file allocation table because the computer would not have been shut down properly.
- The stress of regular, unnoticed surges gradually deteriorating your computer's components.
- Sags causing a system crash and the possible loss of data.
- A strong spike frying your PC.

If you live in an area of frequent storms or windy weather that might cause your power to go out, a surge suppressor should be higher up on your birthday wish list than if storms are infrequent. Nevertheless, given our creeping dependence on computers and stored data, a surge suppressor is a good idea wherever you are. (Sorting through all the competing claims by different manufacturers is another issue altogether.)

Suppressors for Everyone

If you search the Web for surge suppressors or go into a computer store, you'll be surprised at how many manufacturers have the absolutely best product available. They can't even agree on the best criteria to judge suppressors. What's a consumer to do? Simple: Pick the suppressor with the best warranty. Such a warranty will guarantee the following:

- Repair or replacement of the suppressor and any connected equipment *for life* if the suppressor fails to protect against surges
- Payment for the retrieval of lost data
- A high maximum dollar amount for damages

This kind of guarantee doesn't come as cheaply as a less-inclusive one, but it does make choosing a suppressor a lot easier than wading through the claims and manufacturers' specifications. If you must wade, here are some considerations before you purchase:

- The suppressor should have at least a UL 1449-330-volt let-through rating (the lowest amount of voltage the suppressor allows to pass through). This is basically a safety rating. A higher rating, UL Adjunct Endurance Testing, meets tougher government Commercial Item Description (CID) Class, Grade, and Mode specifications.
- Telephone line, fax line, and coaxial cable line protection should be provided.
- It should have a high joule rating. (This measures your suppressor's capability to absorb energy, which is measured in joules.)
- It should have high surge amp ratings.
- The suppressor should have an indicator light to show that the device is working.
- It should provide protection in all three modes (surges between hot, neutral, and ground lines).
- It should have instantaneous response time.
- The unit should shut off power to all of its outlets once the unit has reached its capacity to protect.
- It should offer a broad degree of EMI/RFI noise reduction.

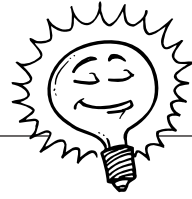

Bright Idea

Don't take a chance on losing any of your computer data, even if you have a top-quality surge suppressor. Follow the golden rules of computing by regularly saving your data and making backup copies. No lightning bolt is going to jump out of your wall receptacle and cook a ZIP disk after it's been removed from its drive.



Positively Shocking

Most surge suppressors require a grounded receptacle. Replacing an old two-wire receptacle with a GFCI will protect you, but it will not ground any equipment plugged into it. In addition, a grounded receptacle will help protect equipment from static electricity.

Competing claims among surge-suppressor manufacturers start sounding like taunts between opposing cliques in the schoolyard. It begins to sound like the Macintosh versus PC battle. My advice? I'd still buy the suppressor with the best guarantee for my price range. Any damage to your equipment or data then becomes the manufacturer's problem. (Read the guarantee carefully.)

Speaking About Computers

A couple other tech toys you might not have known you desperately needed are line conditioners and an uninterrupted power supply (UPS). A line conditioner adjusts the line voltage to a norm, getting rid of highs and lows. This is a good piece of equipment to have if your home electrical system has a regular case of the sags. A UPS is basically a sophisticated battery pack with various filtering properties that kick in when you

have a power outage. The key word here is "battery." You don't want to be running your laser printer or copying machine off of this if you lose power. Use it for your computer, not the peripherals.

More Rules

Surge suppressors come with a few guidelines as well, just like extension cords. These guidelines include ...

- Don't go beyond the electrical rating of the suppressor.
- Surge suppressors are designed for indoor use in dry areas.
- Don't plug the suppressor into an extension cord.
- Keep children and pets away from the suppressor's power cord.
- Suppressors are not designed to be used with aquariums.

Going Whole Hog

Some available systems offer protection starting at your home's meter. A suppressor is installed near the electric meter, and it protects major appliances from surges and lightning strikes. Standard plug-in suppressors are installed inside your home for more sensitive equipment. The Square D company manufactures an inexpensive surge suppressor that mounts directly in the service panel like a two-pole breaker. Talk with your utility company to inquire about these whole-house systems.

The Least You Need to Know

- Extension cords are widely used, but they are not always used appropriately.
- For most jobs, a heavy-gauge extension cord is a safe choice.
- Give your extension cord a quick inspection before, during, and after a job.
- Sorting out competing surge-suppressor claims can be confusing. Always look for a solid guarantee against damage and data loss.



Electing for Electricians

In This Chapter

- You and your contractor
- Working on the plans
- Understanding your contract
- Knowing who does what
- Choice materials, choice results

Few homeowners do all the necessary electrical work on an old house. Upgrading a service, tying into old circuits, and rewiring existing ceiling lights can be intimidating tasks (of course, that's why you bought this book). Even if you choose to do more limited electrical work and hire the rest out, a good working knowledge of electricity and your home's electrical system will enable you to discuss the job intelligently with your electrician and to compare bids more critically.

When you hire a contractor, you each have your respective responsibilities and expectations. You need to clearly communicate what you want done and the time frame in which it must be completed. The contractor must be equally clear in stating the work as he or she understands it from your plans, the cost for labor and materials, and a reasonable completion date. Any changes by either party must be negotiated.

This might be a new experience for you. You'll find this stranger and perhaps a crew of one or two people wandering around your house in work boots, punching holes in the walls, and shutting your power off from time to time. Who are these people and

how do you deal with them? Suddenly you're an employer of sorts, hoping these new employees are going to work out before you write them a check.

You and your contractor should have the same goal: an efficient job done as agreed to in advance with a minimum of disruption. Don't worry, clear communications with a carefully selected electrician—and maybe a box of doughnuts in the morning—will smooth the way for everyone involved.

Hiring It Out

The most meaningful compliment I received about my last book, *The Complete Idiot's Guide to Remodeling Your Home*, came from the production editor. She read the book while in the process of buying her first house and hiring a home inspector to give the place a once-over. He told her he was impressed with how much she knew. Her knowledge allowed her to intelligently scrutinize her potential new home and more clearly understand the inspector's comments and observations.

You'll want to be knowledgeable as well, not only about your electrical system but also about contractors. A contract, whether it's oral or written, is a legally binding agreement. You need to know your rights, the contractor's rights, the bidding process, and payment schedules. There also are intangibles such as your personal reactions to individual electricians bidding the job. If red flags start popping up in front of your eyes, you should start looking for another electrician.

First, however, you have to *find* an electrician.



Bright Idea

In prosperous times, contractors tend to be booked solid weeks and months in advance. Even getting an estimate can be difficult, especially during the summer months. Plan ahead as far as possible.

Contracting for a Contractor

If you skim the Yellow Pages, you'll find lots of listings for electrical contractors, but that's not the best way to choose one for your job. You probably didn't find your physician, dentist, or auto mechanic this way, so why choose an electrician blindly? Do what you did with all the other professionals in your life—get some referrals.

Start with other homeowners. They will be your most obvious resource, particularly if they've done any remodeling. Ask your friends, family, co-workers, even your dentist! There is no guarantee that a contractor will give you the same results in your home, but there's a good chance you'll be satisfied with the results of a referral. Most small contractors survive on referrals and will want yours as well.

A contractor's time is valuable, so don't call a dozen of them to give you a price for adding one circuit to your house. A larger job (such as a service change or a total rewire) is another matter, and three or four bids would not be inappropriate. First, however, there are a few legalities to consider.

License and Bonding Spoken Here

Unless you live buried away in the extreme northeast corner of Montana in an area so remote that no one, not even the IRS or junk mailers, knows it exists, you should expect an electrician to be licensed, bonded, and insured in accordance with local and state laws. These requirements are fairly standard across the country. They protect you and the contractor from each other if problems arise.

A license is simply permission from a governing authority to do a specific business. It shows that a contractor is registered, often with both the city and the state, and has met certain standards. This enables a contractor to hang a shingle out and say, "I'm an electrician." It also means the local government has collected a registration fee and will be collecting taxes from the licensee.

Two requirements usually have to be met before a contractor's license is issued:

- The individual must be bonded.
- The business must be insured.

The Name's Bond, Surety Bond

A contractor's bond (*surety bond*) is required in many states before a contractor will be issued a license to operate. The bond helps guarantee that a contractor will perform according to the terms of a contract. I suppose it's not much different in principle from a jail bond, which is an attempt to guarantee a defendant's appearance in court, but with a more wholesome connotation.

A bond is registered with a governing authority in one of two ways:

- The contractor can establish a special account with a cash deposit equivalent to the amount of the bond.
- A bonding company can be engaged for a fee.



Positively Shocking

Make sure your electrician's license, bond, and insurance are current. All three should be renewed on a yearly basis. If you have any questions at all, call your city or state department of licensing and do a credentials check. You don't want any problems from hiring an unlicensed individual.



Ask an Electrician

Webster's Dictionary defines **surety** as "a guarantee, assurance, or certainty" and dates the origins of the word back to the fourteenth century. The term **surety bond** dates back to the early twentieth century as "a bond guaranteeing performance of a contract or obligation."

The amount of the bond varies from state to state. In Washington, for example, the bonding rates are relatively low. A general contractor only has to post a \$6,000 bond, and a specialty contractor or subcontractor (electricians, plumbers, painters, and so on) must post only a \$4,000 bond. If you are not satisfied with a contractor's work, you can put in a claim against the bond, although you're limited to its dollar amount. This isn't much consolation if all you can collect is a fraction of the value of the work, and you must pursue additional financial relief through the courts or arbitration.

Any claim against a contractor must be legitimate. You have to prove that the work was not done to the specifications agreed to in your contract. Just as a bond gives you some leverage in the event of faulty work, a *lien* (sounds like "lean," appropriately enough) gives a contractor some protection against a customer's spurious claims. Sometimes called a *mechanic's lien*, this

handy piece of legal work enables a contractor to file a claim against your home until your debt is paid. This doesn't mean your contractor is going to take up residence in your spare bedroom if you don't pay, but the lien must be satisfied before the property can be sold. In some cases, a forced sale of the property can occur.



Electrical Elaboration

A contractor's bond is the minimum amount needed to establish a business and become licensed. For large jobs, especially commercial work, the client usually requires a performance bond in an amount equal to the entire value of the job. Performance bonds typically are taken out through a bonding company. (Otherwise, they would tie up too much capital for most contractors.)

Insurance Is a Must

I once did an Internet search for insurance jokes, and I couldn't find any. There were plenty of jokes about lawyers, doctors, and even some about accountants, but

insurance seems to have escaped the comical wrath of joke writers. This is the bottom line: You want your contractor to be fully insured.

Proof of insurance usually is a requirement for a contractor to obtain a license. Insurance protects you if there's an accident or damage during the course of the work. In addition to a general liability policy, contractors must cover their employees with government-mandated policies such as workers' compensation.

Three in One

A legitimate contractor will be licensed, bonded, and insured. Without all three of these qualifications, you're putting yourself and your home at risk. If a cash-only, unlicensed, we-don't-need-no-stinkin'-contract electrician works on your house and falls off a ladder, shorts out an appliance, or incorrectly wires a circuit that causes a fire, you might never receive compensation for damages. When a licensed electrician causes a problem, you have some legal assurances the problem can eventually be paid for.

Plans and Specifications—Always!

You can't expect someone to bid on a job if you don't specify exactly what you want done. It's not enough to say, "Just add some receptacles and lights wherever you think we need them." You have to specify where you want them, the types of fixtures you want, and even the styles of light bulbs. You don't need detailed plans and specifications for everything. Adding a clothes-dryer circuit, for example, is pretty straightforward once you've designated where the laundry will be located.

Details increase as the scope of the job increases. Installing a new service panel might mean a different location than an existing box. (This obviously is true when an old fuse box located off a back porch is replaced.) A complete update of your existing system, including running all new wire, would have to be detailed, especially when it comes to fixtures and their locations. The following list outlines a very basic plan:

Sample House Plan

Main service: 200-amp Square D QO service panel

Location: NE corner of basement

Existing fuse box will serve as a junction box for any existing circuits to be retained. The door will be screwed shut.

New circuits to be added: Washing machine, dryer

Kitchen: Add two 20-amp small-appliance circuits with GFCIs, white Leviton receptacles, and cover plates. Install nine recessed cans (white trim) with dimmer switch (white) and two 18-inch fluorescent fixtures over counters. Run outlet for range and separate circuits for microwave, refrigerator, and disposer.

Lighting: Add sufficient 15-amp circuits to bring bedrooms, living and dining room, and hallway up to code for receptacles (six-foot rule).

Office: Run dedicated 15-amp computer circuit.

Master bathroom: Run GFCI. Install six-light fixture over mirror and recessed can over toilet (white trim). Install Nutone QT-200 fan.

First-floor bath: Run GFCI. Install four-light fixture over mirror. Install Nutone QT-100 fan.

Living room: Install four wall sconces and one recessed can over fireplace.

Dining: Use existing chandelier. Check wiring for safety.

Bedroom hallway: Use existing fixture and check wiring.

Use existing bedroom ceiling lights and check wiring.

Basement: Run 20-amp circuit for workshop. Install four-foot fluorescent fixtures. Install six ceramic light fixtures in basement ceiling, locations to be marked.

Garage: Run GFCI and one light over each car bay. Run wiring for two garage-door openers (to be installed by others).

Front porch: Install new porch light (Nautilus style). Install GFCI for outdoor use.

Rear porch: Use existing light and check wiring. Install GFCI for outdoor use.

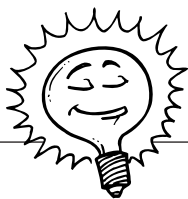

Bright Idea

Large home-improvement centers and specialty retailers are great places to visit to see current types of fixtures and lighting systems. Visit a number of establishments before making your final decisions. Check out disposers, fans, and other small-electrical items you might be installing as well.

Contractor will supply all labor and materials and will remove any refuse from job site. Job will be kept broom-clean daily. Billing will be done in two installments with a 10-percent down payment to be applied toward materials.

Who Draws Them Up?

You, your designer, or your electrician will draw up or sketch any plans for the electrical work. Written descriptions (“locate panel in NE corner of basement”) usually are adequate for most residential jobs. Specific light locations, however, should be noted on a sketch or plan of the room. It’s not a bad idea to put some kind of marker on the wall, such as blue masking tape, to confirm the location. An architect’s or designer’s plans for a general remodel should note any electrical requirements.

Allowing Substitutions

As remodeling bids come in and budgets get stretched, your imported marble countertop might suddenly become plastic laminate and your oak floor might become vinyl. The same is true with electrical work. Lights, appliances, and garage-door openers are available in a range of models and prices. Sometimes your electrician can come up with an equivalent-model fixture at a lower price with no appreciable difference in quality or appearance. Your bids and specifications should allow for such substitutions.

Comparing Bids

A clear set of plans and specifications enables all the bidding electricians to play by the same set of ground rules. It also helps you fairly compare their prices. You'll find, as you put a job out to bid, that each electrician has a slightly different take on how to do the work and what materials to use. Keep these suggestions in mind as you scrutinize the bids so you can adjust for specific differences in cost.

Let's say you want a standard, switch-controlled light to be installed outside your garage. One of your bidders might suggest that you put in a motion detector instead, which will automatically turn on the light when it detects someone moving nearby. Another bidder might suggest that you install a larger ventilation fan in your kitchen. The service panel is the big item. If you specify one brand and an electrician recommends another, find out why and compare the differences in cost by calling an electrical wholesaler.

About Those Contracts

Some contractors—and homeowners—want a written contract for everything. This is unnecessary for small jobs, but there's no harm in writing up a short letter of intent. You could say, for example, "Contractor will supply all labor and materials for one new bathroom circuit with GFCI receptacle for the sum of _____ dollars plus applicable tax. Homeowner will take care of any wall repair or patching." For that matter, your contractor might supply a contract form for small jobs with a written description of the work and ask for your signature to confirm your acceptance.

Larger jobs usually require a written contract. If your electrician is hesitant to provide one or to sign yours, find someone else to do the work. No legitimate contractor will shy away from a valid contract.

Write It Down

A contract should include everything you want done. Don't assume that your electrician can read your mind and will install cream-colored receptacles when white is more common. If you have any questions, ask before you sign.



Electrical Elaboration

In addition to describing the job and the materials to be installed, a contract also should state the terms of payment. Some contractors will want a percentage in advance (depending on the size of the job). Some states limit this percentage. You also might be asked to pay to order materials in advance. If the demand for prepayment seems unreasonable (it's easy enough to find out the cost of the materials by calling a wholesaler), find another electrician. You'll know after you get a couple of competing bids if someone is way out of line or not.

Change Orders

A *change order* is a modification to a contract. It can be initiated by either you or your contractor, but it must be agreed to by both. You might decide to add more lights, for example, or a different type of fixture. Your electrician might run across unforeseen problems such as an existing circuit that must be replaced (when you assumed it could still be used). A change order usually means an increase in the price of the job, but this is not always the case. You might decide to eliminate some fixtures or to go for less-expensive ones, thus lowering your overall cost.

The best change order, ideally, is *no* change order. Change orders can delay a job and might cause your electrician to have to undo work completed under your original specifications to accommodate the requested change. No plan is perfect. Remodeling is a fluid experience. As it progresses, you might see things you did not see during the planning stages. A skylight in the bedroom might become more desirable than the track lighting that just went in this morning. Don't laugh, I had a client with more money than sense who did just that. Out came the new drywall and lights; in went new skylights and windows into newly finished rooms. At least he kept the carpenters employed and happy.

A Deal's a Deal

After you've agreed to the job and have signed on the dotted line, you have to hold up your end of things, too. This means ...

- Clearing furniture and household items out of the way so your electrician can work.

- Keeping your children at a safe distance from the work activity.
- Controlling your pets.
- Providing access to your house, either with a key or by being home at the start of the workday.
- Understanding that your contractor and any crew will need access to a bathroom and somewhere to take their breaks.
- Paying your bill in a timely manner. Small contractors are especially dependent on regular cash flow, and you shouldn't unnecessarily delay payment.

Being a good customer is just as important as being a good contractor—all good contractors have stories about customers from hell.



Positively Shocking

Your electrician can rightfully put a clause in your contract that he or she will not assume any responsibility for damage to household items left in the way or not adequately protected on the work site. This includes anything hanging on a wall that could loosen and fall from hammering, sawing, or drilling through the wall.

Cleanup and Wall-Repair Woes

In an existing house, any extensive rewiring will require opening up some walls and ceilings by cutting into the drywall or plaster. Electricians have two conflicting issues here: One voice—yours—says keep the holes small; the other voice—the electrician's—says a larger hole makes the job easier and faster. Guess which one wins out? I'm not against electricians, and no, it doesn't mean they're going to knock a three-foot-by-three-foot hole in your wall just to pull one wire through it. It does mean, however, that you'll have some wall and ceiling repairs to do after the electrician is finished.



Electrical Elaboration

Major electrical work requires more than one inspection. An initial inspection covers the rough-in work, the running and securing of cable inside the walls. When this passes inspection, it's "good to cover," which means the drywall or plaster can be installed. You cannot cover electrical work until it's been inspected, so don't schedule it until after the inspection.

Drywall and plaster repair costs need to be figured into your electrical budget unless you do the work yourself (see Chapter 15, “Working Around Existing Wiring”). It doesn’t stop there, however. Your electrician might have to drill through paneling or wallpaper whose patching is a little more problematic. If a room hasn’t been painted in many years, the paint will have faded and won’t necessarily match up very well with the can of Colonial blue latex sitting in the garage. Figure this into your planning costs so it’s not such a surprise later.

Electricians Hate Plaster Walls

I wouldn’t go so far as to suggest that plaster walls are a nemesis of electricians, but they’re not exactly fond of them. Some plaster, particularly from the Victorian era, can be very brittle and will fall apart easily when being cut through. All it takes is a piece of wood lath vibrating roughly and a four-inch hole becomes a 12-inch crack. Worse yet is metal lath, which can be a mess to cut through. Don’t be surprised if a bidding electrician figures in extra cost if you have plaster walls.

Fire Blocks

A fire block is a horizontal 2×4 nailed between two wall studs to slow the spread of fire through the wall. Electricians find them the hard way when they drop a fish tape or chain (used for pulling electrical cable through finished walls), only to find them blocked part of the way down. This requires cutting into the wall near the block and drilling through it to get the cable through. In addition to slowing down the job, it means more wall repairs for you to do later.

The Least You Need to Know

- Other homeowners will be your best source of referrals when you’re looking for an electrician.
- Only hire a licensed, bonded, and insured electrician to work on your home.
- Clearly written job specifications help both you and the electrician come up with an accurate, fair price for the job.
- Only sign contracts that you fully understand; if you have any questions, ask away.
- As a customer, understand your responsibilities to your contractor.
- Be prepared to do some wall and ceiling patching after major electrical work.

Part 3

Components and Simple Repairs

Enough with the theories, history, and precautions. Now it's time to do something with your new tools and newfound knowledge. Older homes always have small electrical jobs to do—from repairing a lamp cord to replacing a switch. These are good jobs to start with until you're comfortable working around electricity.

The chapters in Part 3 will walk you through basic repairs and troubleshooting. Because these are small jobs, you won't have to live in the dark with all your power shut off in the event that you don't finish on the day you start the work. The small jobs (such as replacing an old receptacle or switch) will take less than an hour (apprehension factor included).

Repair and replacement mean new components: switches, receptacles, wires, and lights. I'll discuss all the different flavors, from a plain-vanilla-white duplex receptacle to a four-way switch with a brass cover plate. Chapter 15 will show you how to get your cable from one point to another without tearing up your house too much in the process. These chapters won't make you a card-carrying journeyman electrician, but they will give you a much better sense of the work involved and your degree of comfort with it.

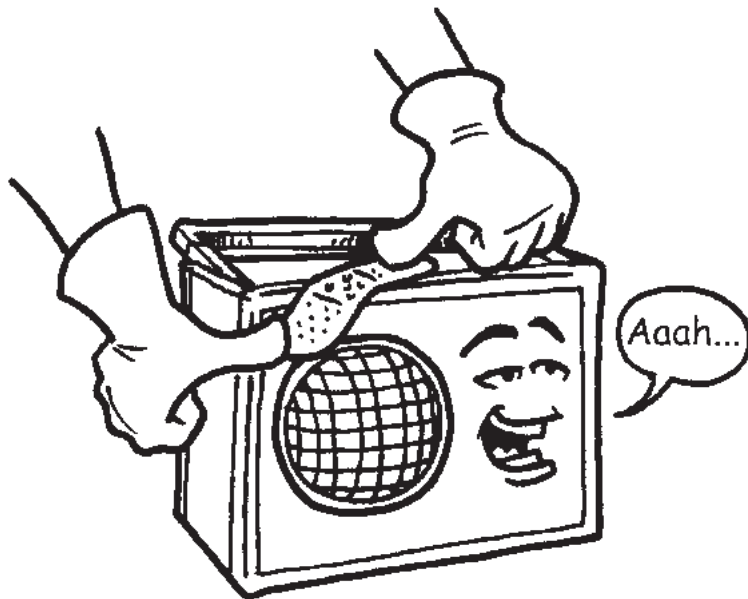



Switches and Receptacles

In This Chapter

- Know what each device does
- GFCIs in detail
- Two- and three-wire receptacles
- Choosing the right-size box
- Cover-plate choices

We use them every day, but we don't think about them much. This is a good indication of the reliability of switches and receptacles. A bathroom light switch, for example, might be clicked on and off 10 times a day (depending on the size of your family). That's a few thousand clicks each year, and the switch keeps going and going. If only our computers and operating systems were that reliable.

A switch controls the flow of electricity between a source and an end device such as a light fixture. In a standard modern light switch, a metal arm inside the switch connects the two screw terminals to which the black, or hot, wires are connected. In the "Off" position, this arm moves out of the way and cuts off the flow of electricity along the conductors.

Receptacles don't face as much mechanical wear and tear as a switch undergoes. A common house receptacle is called a duplex receptacle because it can accommodate two plugs. The metal connector between the screw terminals is fixed in place, unlike

the movable arm in a switch. Each prong of a plug is held in place by two pieces of spring metal to maintain a solid electrical contact.

Both switches and receptacles can wear out, especially the original ones in an old home. This chapter discusses the most common types and some of the less-common ones as well.

There's One for Every Purpose

The world of electrical devices is quite varied. The light switch in your bedroom isn't quite the same as those at the top and bottom of your staircase. The latter most likely are three-way switches (possibly four-way), which control an electrical load (in this case, the light) from more than one location. You might have an emergency switch that controls your oil furnace or a timer switch connected to a bathroom fan. You need to know one from another when you go to replace an existing switch or install a new one.

Receptacles are no different. You're already familiar with a standard duplex outlet (your house is full of them) and a GFCI receptacle. There also are single receptacles that take one plug, receptacles for clothes dryers and electric ranges that carry both 120 and 240 volts, and special hospital-grade receptacles. Older homes might have original unpolarized receptacles or even some old twist-lock-style receptacles. You have to know what you're dealing with before you replace it; otherwise, you could create a hazardous situation.

As always, follow the unwritten rule of electrical work: Buy only UL-approved materials. The world of Internet trading and crashing trade barriers means more nonlisted devices than ever will be available, but stick with the tried and true, even if your code allows the others. You want some assurances that you're buying a safe product.



Electrical Elaboration

A large appliance receptacle carries both 120 and 240 volts because it has to supply two different loads. A clothes dryer needs 240 volts, but the dryer's timer, lights, motor, and buzzer run on 120 volts. An electric range needs 240 volts but not so its clock and lights.

Switches

The most common switch in your house is a single-pole switch with a toggle marked “On” and “Off.” It typically is used to control a light fixture or a receptacle. *Single-pole* simply refers to electricity flowing in one direction. In most cases, one black (hot) wire is connected to one terminal screw (or it might be back wired), and a second hot wire is connected to the other terminal screw, proceeding on to the light. In terms of physics, a *pole* is just one of two opposite points on a magnet that manifest the magnetic properties. (Remember, a spinning magnet, called a *dynamo*, at your utility’s power plant creates the electric current.) Unlike older switches, modern versions often come with a ground terminal for the green or bare copper ground wire.

A single-pole switch controls the current to its load from one location only. Other switches control the current from two or even three different locations.

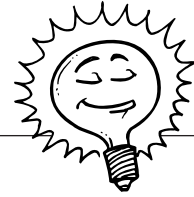

Bright Idea

If you expect to be doing more repairs or modifications to your electrical system in the future, pick up a half a dozen or so extra switches and receptacles to have on hand. It’s a small investment to make for the convenience of having them when you need them.

Three-Way Switch

Three-way switches come in twos so you can control a light from two locations. Their most common location is at the top and bottom of a staircase or at opposite ends of a large room with more than one entrance. Three-way switches come with three terminal screws: Two are the *traveler* screw terminals; the third, which is darker in color, is the *common* screw terminal. The traveler terminals connect one switch to the other. The cable that runs between the switches has two hot wires: one neutral, and one ground, as shown in the following diagram.

Four-Way Switch

This one is always found between a pair of three-way switches. You’d have to have a *really* long hallway or a large room needing switch controls from three locations. A four-way switch comes with two pairs of color-matched terminal screws that conveniently connect with color-matched wires from the two three-way switches.

A three-way switch, traveler screw terminals, and a common screw terminal.

(Courtesy of Leviton)

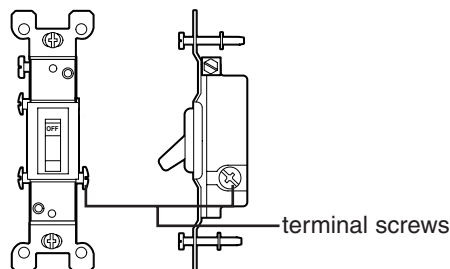

Electrical Elaboration

Switches weren't always the familiar toggle design we use today. A rotary-style switch, which was turned clockwise to open and close a current, was used at the turn of the century. In the 1920s and 1930s, push-button switches were introduced, and they are still in working condition in period homes. Early toggle switches were first manufactured in the 1930s.

Switch/Receptacle Combo

This handy device is half receptacle and half switch. It's a quick way to add a receptacle to a room (after you've calculated the amperage of the new load—remember not to overload your circuits). The receptacle will be at switch height, which typically is four feet from the floor to the top of the receptacle box. The switch and the receptacle can operate independently of each other, or the receptacle can be controlled by the switch, perhaps for a hanging ceiling lamp not directly wired to a circuit that came with a lamp cord and plug.

A naked switch/receptacle.

(Courtesy of Leviton)



Ganging Up

Switches for multiple light fixtures often are *ganged* up in one box. If all the lights are on the same circuit, one feed wire from the panel will supply the power for all the switches and their loads. A separate cable will run to each fixture. Sometimes you'll run across a single gang box with a double switch, but this isn't very common in residential systems.

How many switches can you fit in one box? Leviton offers one switch plate that has space for 10 switches. You'll find these in commercial settings or maybe in an Internet gazzillionaire's new mansion.

Pilot-Light Switch

A pilot-light switch resembles a standard single-pole switch, except it has a built-in bulb (either the toggle is illuminated or the bulb is on the face of the switch) that lights up when the switch is in the "On" position. This usually is installed when the fixture or light is out of sight of the switch (say, a light in a detached garage). The illuminated switch lets you know if someone forgot to turn the lights off.

Dimmers

In addition to their romantic value, dimmer switches enable you to decrease the lighting in the dining room so your kids can't see that you're feeding them Brussels sprouts, a side dish that no human being should ever eat anyway. Dimmer switches come in several styles including those with ...

- A toggle control.
- A dial control.
- A sliding control.
- Automatic dimming.

A dimmer reduces the voltage reaching a light fixture, but in doing so, the switch builds up a small amount of heat. Because of this heat and the large size of a dimmer switch compared to other switches, it might not work as a replacement for an existing switch if you have an undersized or crowded box.



Ask an Electrician

One definition of **gang** is "combining electrical boxes together to form a larger box for additional switches or receptacles." You can buy premade boxes in an appropriate size, or you can combine metal boxes that have removable side walls. Plastic boxes aren't meant to be ganged together and will become damaged if you attempt to do so.

Timers and Doorbells

Timers, either manual or automatic, also are types of switches. Manual timers regularly are used with bathroom fans and heat lamps. A frequent residential use of automatic timers is to control a whole-house ventilation system.

Doorbells are switches, too. When you press the button, a low-voltage current flows to the chimes or the buzzer. Thermostats are another low-voltage switch, except these are activated by temperature changes. Elaborate thermostats have separate switches for controlling the furnace fan and for turning heat and air conditioning on and off manually.

Receptacles Galore

Most of the receptacles in your home are the duplex type and have been in common use for the better part of the century. Current versions differ from those used through the 1950s because the newer ones have a grounding hole. Polarized receptacles came into use in the 1920s (see Chapter 4, “If Your Walls Could Talk”). The different-size slots (the longer one always goes with the neutral wire, the shorter with the hot) maintain consistent, directed current flow along the respective hot and neutral wires.

The earliest receptacles were an odd arrangement. The plug-in part of the outlet was actually a screw-in affair, something like a light bulb. The receptacle plate had a small flap that flipped up to reveal a socket into which the plug-in was screwed. (Hey, electrification had to start somewhere.)



Positively Shocking

This bears repeating: Never file down or otherwise alter a polarized plug so it will fit into a non-polarized receptacle. Use your electrical components the way they were designed. If you only have nonpolarized receptacles, use adapters for your polarized plugs.

The following are specialized types of duplex receptacles:

- Floor receptacles
- Clock receptacles
- GFCIs

Floor receptacles are specially designed to withstand foot traffic. They are installed in the middle of large rooms or in other areas far away from a wall receptacle. They often are seen in offices and other commercial settings with large, undivided floor spaces.

A clock receptacle is recessed so that a clock and its cord can be hung flush against a wall. You used to see these more often in kitchens, but you don't see them as often now, especially since the advent of inexpensive battery-powered wall clocks. This type of receptacle is now more common for plugging in microwaves and for picture lights that plug in behind pictures and paintings.

A GFCI can be used for a single location such as a bathroom or a kitchen, or it can offer protection to an entire circuit of receptacles or other loads. This is possible only if the GFCI is the first receptacle on a circuit. From that point on, anything beyond it on the same circuit will have GFCI protection. If it's in the middle of a circuit or in any other position than the first receptacle, it will not offer any protection to any load between it and the service panel.

Don't Forget the Boxes

The NEC code requires that any wires connected to each other or attached to a fixture or device must be enclosed in a box with a cover plate. This means that receptacles, switches, lights, wall heaters, anything that requires electricity will have its wiring housed in a box. A box serves a number of purposes:

- It serves as a point of attachment for a device or a fixture. (It has to be screwed to something.)
- It keeps wires that could short and then spark away from wood framing, decreasing the possibility of fire.
- It protects people from accidental exposure to wires and possible shock.

There are boxes for every purpose: ceiling lights, retrofitting fixtures into existing walls, weather-proof designs for outdoor use, and junctions for wire connections that aren't immediately attached to a device or fixture. As with switches and receptacles, you'll have to choose the right box for the job at hand.

They're Not All the Same

The following is a list of the most common electrical boxes:

- Rectangular for switches and receptacles
- Square for junctions or two receptacles/switches
- Octagonal and round for ceiling fixtures

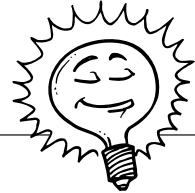

Bright Idea

Consider buying a package of child-protective caps to stick into any unused receptacles, even if you don't have small children in the house. You never know when you might have overnight guests with toddlers. Some receptacle covers snap tightly in place for something more permanent.



Positively Shocking

Never conceal an electrical box! The NEC states that these boxes must remain visible and accessible, even if it seems unimportant to you.

- Retrofit types for inserting into existing walls and ceilings
- Aluminum and PVC plastic for exterior use
- Boxes with extendible bars or braces for attaching between joist
- Pancake boxes for limited circumstances when a regular box is too deep for the wall or ceiling space (Most of the plastic ones are not listed as tested by UL, and the metal ones are rated for only one cable, usually 14 gauge.)
- Fan-rated boxes—the only boxes you can use to install paddle fans

Boxes can be attached to framing, plaster, and drywall in a variety of ways, as shown in the following figures.

A single gang plastic box with nails.

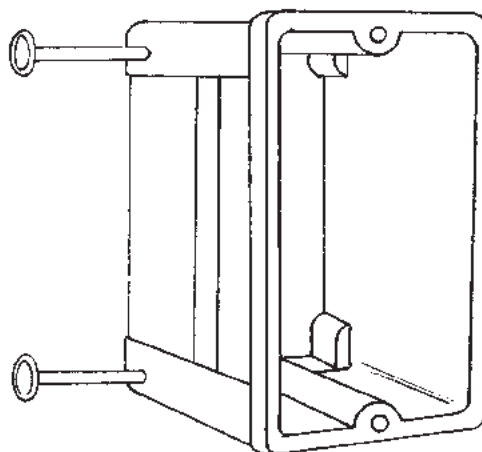

A double gang metal box with a bracket.

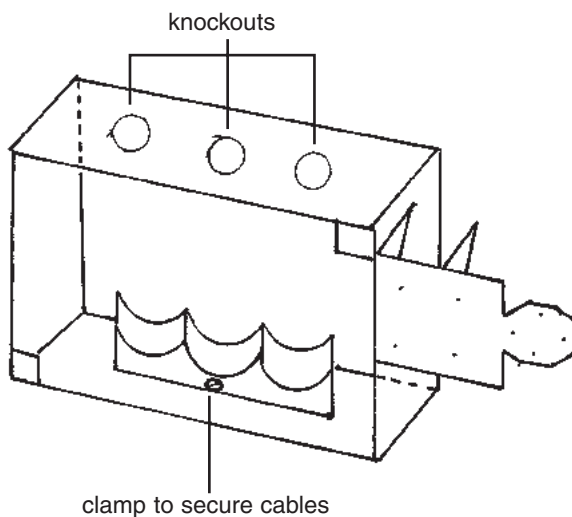

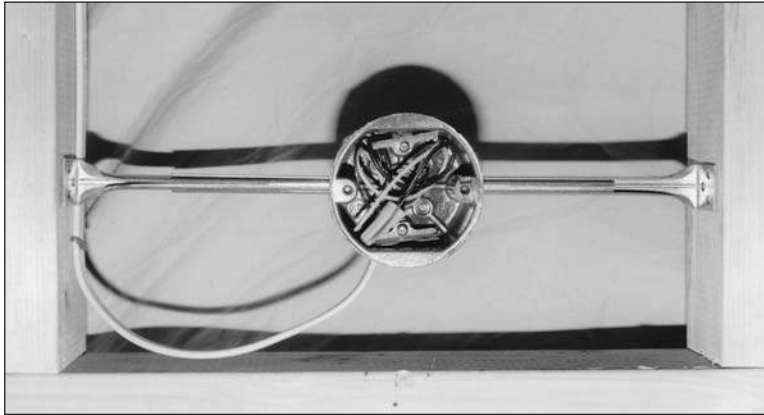

A round box with extendible bars.

Plastic or Steel?

Both plastic and steel boxes are used in residential construction. A box has to withstand a certain amount of construction trauma when it's installed and later when drywall is installed around it. (Drywall hangers are not necessarily kind and gentle people, at least not when they're getting paid by the square foot.) Plastic boxes are lightweight and are easy to install, especially those that come with nails for direct attachment to a wall stud or a floor joist.

Metal boxes are standard in most commercial work. Unlike a plastic box, a metal box is a good conductor of electricity and must be grounded along with the device or fixture. Special fittings are used to connect a metal box to conduit and conductors to the box. These fittings include an array of clamps, clips, and locknuts, most of which you'll never use in the course of residential repairs and remodeling.

A plastic box works well for a single gang or device use, but some electricians find that a larger plastic box's shape distorts during installation or when the drywall is installed. For these reasons, they use tougher boxes, either Bakelite (reinforced phenolic) or metal for two gang installations and metal for three gang. The larger the box, the more difficult it is to keep it level and in line.

Check the Size

Boxes come in different sizes based on the installation need. Rectangular boxes, the most common ones used for single devices, generally are two inches by three inches for residential use. Depth ranges from $1\frac{5}{8}$ inches to $3\frac{19}{32}$ inches. The deeper the box, the more wires it can accommodate and the easier it is to tuck in the wires and install a device and still meet code. You'll really appreciate this when you're dealing with 12-gauge wire.

How many cables can your box accommodate? Well, the bigger the box the better, but to be more exact ...

- Count the number of intended cables for the box. Each hot and neutral conductor counts as one wire each, and all the grounding conductors together count as a single wire.
- Take this total and add one for any cable clamps (if they're the same type of clamp). If you have two different types, you have to count each as a separate number.
- Take this new total and add two for each device (switch or receptacle).
- If the box contains 14-gauge wire, multiply the total number (of wires, clamps, and devices) by 2 cubic inches. If 12-gauge wire is being used, multiply the total by 2.25 cubic inches.
- The result of this multiplication is the minimum allowable volume of wires, clamps, and devices for that box. (The volume of a box usually is stamped on the back of the inside of the box.)

Let's say you have a light switch in a plastic box with two 14-gauge cables coming into it. (One is the line; one is the load.) This gives you two hot conductors, two neutrals, two grounding conductors (these count as one wire in our calculations), and one switch. Therefore ...

Two hot conductors: 2

Two neutrals: 2

One grounding conductor: 1

Device: 2

Total: 7

7×2 cubic inches = 14 cubic inch minimum box size

(Note: Most plastic boxes do not have any type of clamp.)

Cover 'Em Up

Every electrical box needs a cover plate. A junction box, which is used solely to house wires and their connections but not devices, needs a blank cover plate. The cover plate keeps probing fingers, especially those of kids, away from the wires and the terminal screws on the device, all of which are fine sources of electrical shock.

Plastic is the material of choice for most cover plates, but metal is used in some commercial work and with metal boxes. Outdoor boxes have plates with foam gaskets to keep moisture out. Outdoor receptacles have additional protection: A section of the cover plate closes over and covers the receptacle when it isn't in use.

Plastic cover plates have been used since the 1920s, but other materials have been used as well.

Brass: New and Old

Many older homes have original brass cover plates, often with a dark bronze tone. These will readily take to a buffing wheel and will come out a fine, shiny brass if that's your preference. New replacement brass plates also are available. Some homeowners and designers install them in kitchens and bathrooms, but such damp locations aren't the best places for brass unless you like polishing them from time to time.

The Artful Flare of Ceramics

If you go to any good-size street fair, at least in a large city, you're likely to run into an artist's booth selling ceramic electrical plates. Some have a theme (such as stars or suns); others are a little more whimsical. Check to see if they're listed by UL; if they're not, decide whether you think it's a problem. These plates are usually ceramic, nonconducting material and can be pricey.

Local gift and design shops might carry these types of plates as well. They usually are purchased for a single room, such as a bathroom or a baby's room, rather than an entire home.

The Least You Need to Know

- Every switch and receptacle has a specific purpose; they're not interchangeable.
- Despite their long working life, devices occasionally need replacement—a simple job for homeowners.
- Every device, fixture, and junction needs an electrical box to meet code requirements.
- Cover plates are required for all boxes so that no wires are exposed, especially to small, probing fingers.

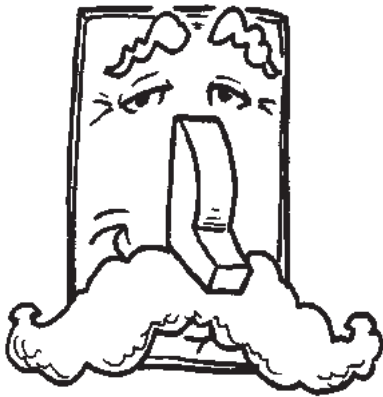

Replacing Old Switches and Receptacles

In This Chapter

- Shutting the power off first
- Picking the right device
- Working with old wire
- Upgrading old receptacles

Now that you know about switches and receptacles, it's time to replace any that are broken or to upgrade existing ones. The most common upgrade is swapping a standard toggle switch for a dimmer. Newer, quieter models—that don't have the resounding “click” of old switches—sometimes are installed in older homes that still have their original devices.

The most common reason for replacing a device is wear and tear. The clips in a receptacle that hold a plug tautly or the metal arm in a switch eventually can fatigue and no longer work properly. A simple loss of power to a fixture or an appliance, however, is not necessarily a reason to replace a device. You have to do a few system checks first, which we'll discuss in this chapter.

The short projects in this chapter will help you get your feet wet—don't take that literally, however, when working around electricity—and gain a degree of comfort with your electrical system. Three- and four-way switches require more troubleshooting skills, but we'll cover the most common situations with both switches. We'll also discuss upgrading your current two-wire receptacles and making them safer when the situation calls for it—without updating the entire system with a grounded conductor.

Probing the Problem

You flick the light switch and nothing happens. The coffeemaker, which was set on a timer to go off at 6 A.M., sits with pot of cold water on your kitchen counter. Before assuming that the devices are shot, follow this checklist:

- ❑ Confirm that the circuit has power and that the fuse hasn't burned out or the circuit breaker tripped.
- ❑ Check to see if the appliance or fixture is working by checking light bulbs, cords, and plugs.
- ❑ Inspect the connections at the fixture and at the terminal screws to ensure they are tight.
- ❑ Check for a problem in the circuit itself.

The very first thing you should do is confirm that power is getting to the device. Every electrician has a story about going on a service call to repair a dead circuit only to discover that the breaker had tripped and no one checked. That's a pretty expensive discovery for a homeowner. Your first step is to examine your fuse box or service panel.



Positively Shocking

Turn the power off before pulling a device out of a box. This isn't necessary if you can test it without removing it, but you can get shocked during removal if it's shorting. Running down to the panel box only adds a few minutes to the job, but it increases your safety immeasurably.

Does everything look okay? Are there burned-out fuses or tripped breakers for that circuit? Check carefully. Some breakers have very little sponginess and don't move much when they trip. You might have to test several breakers if you haven't done a circuit map and are uncertain which breaker controls the failed device.

If you can eliminate the power source as the problem, check the connections (see the following figure) by taking the following steps:

1. Turn the power off.
2. Remove the cover plate from the device, and unscrew the device from the box.
3. See if the terminal screws are tight and have good contact with the wires.
4. If the device is back wired, there shouldn't be any bare wire showing, only insulation.
5. Check the wire nuts or taped-and-soldered connections to be sure they're tight.

If there are no problems with the connections, you'll have to probe further with your handy voltage tester and a continuity tester.

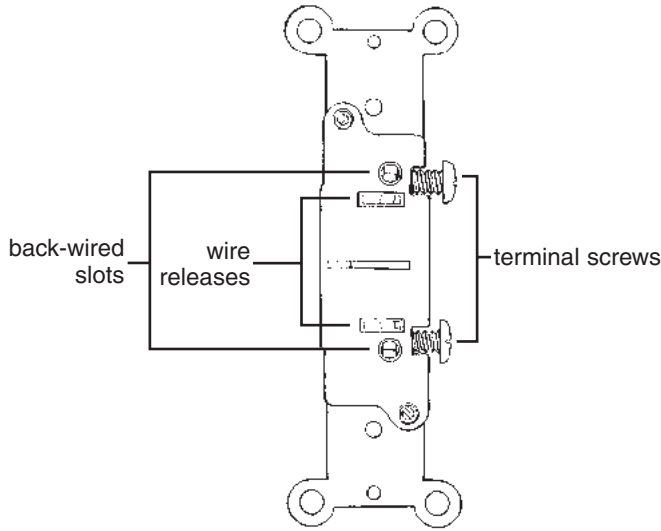

A rear view of a single-pole switch.

Checking the Devices

Switches, appliances, and fixtures test a bit differently than receptacles. The first three are tested for continuity and power and require both testing tools. A continuity tester will indicate whether the circuit's pathway within the switch has any breaks in it from metal fatigue. It also checks other appliances and fixtures for similar breaks. Let's start with testing for a switch.

Follow these steps to test a switch for power:

1. With the switch off, touch one of the voltage tester's probes either to the bare end of the ground wire (the inside of the wire nut holding the neutral wires together) or, if it's a metal box, to the side of the box.
2. Place the other probe against each black wire either at the terminal screw or at the back-wired slot.
3. The bulb should light up for at least one of the hot wires, the line wire coming from the panel or fuse box. If the tester does not light up for either black wire, the problem is somewhere in the circuit between the panel and the device. (Go to step 4 if it does light up.)
4. Turn the switch on and check the other black wire, which is the load conductor. If the bulb on the tester does not light up, the switch is bad and needs to be replaced.
5. If both black wires show current passing through them, recheck the fixture and the appliance because the problem is not with the switch.

6. Note: In some older homes with knob-and-tube wiring, the neutral wire has been switched and used as a “hot” conductor. This makes the task of troubleshooting much more difficult. If you have any questions or concerns while testing, call an electrician.

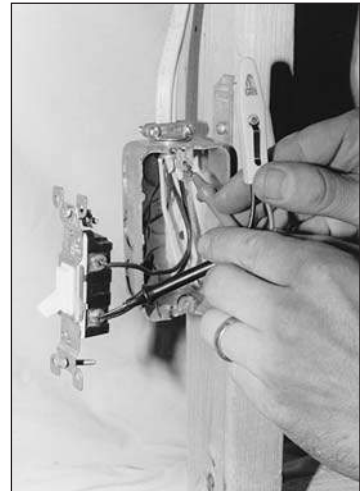
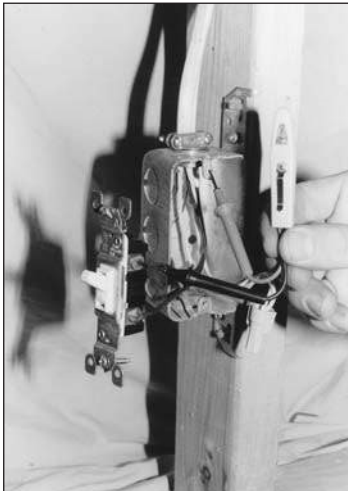
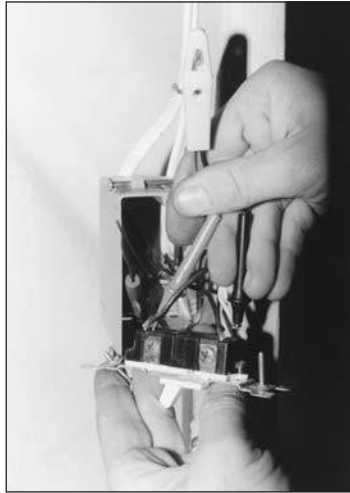
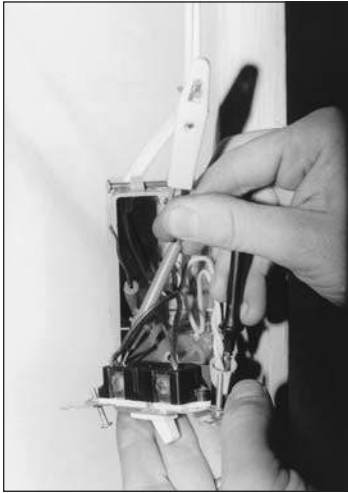

Testing terminals and testing back wiring.

Continuity Coming Up

A continuity test will tell you whether a switch's metal components, which are critical for the flow of the current, are intact or broken. A continuity tester is battery-powered and provides a current that passes from the tester's clip through a device or fixture. The tester's other component is a probe that lights up if a current is passing through the device as designed. To perform the test, a switch or fixture must be disconnected from its power source and removed. (The tester will supply the current for the test.) A continuity tester should never be used on a live current.

The following figures show you how to do a continuity test on a single-pole switch and a three-way switch. If your tests show you that the switch is the problem, it's time to replace it.

If your tests show you that the switch is the problem, it's time to replace it.

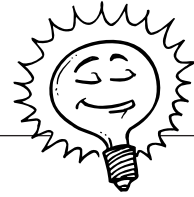

Bright Idea

It's almost easier to simply hook up a new single-pole switch to a circuit than to run a continuity test on one that isn't working. By the time you've tested for voltage and have removed it to test for continuity, you could have popped a new switch in and known right away if the switch is the problem.

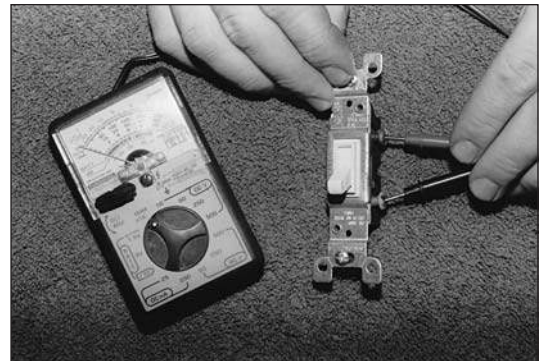
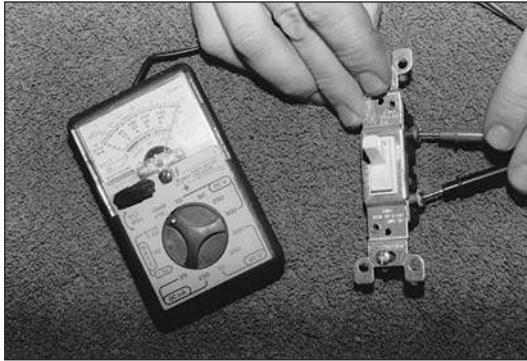

Attach the tester's clip to one of the screw terminals, and attach the probe to the second terminal. Flip the switch to "On" and "Off." If the tester lights up in the "On" position but not in the "Off" position, the switch is good.

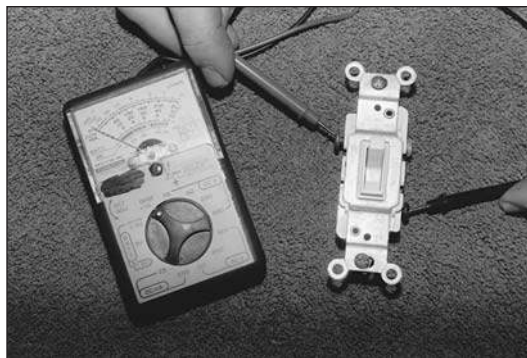
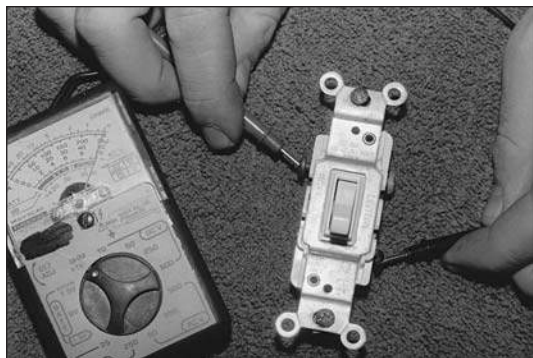
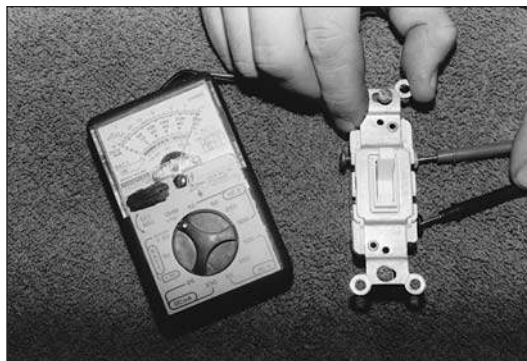
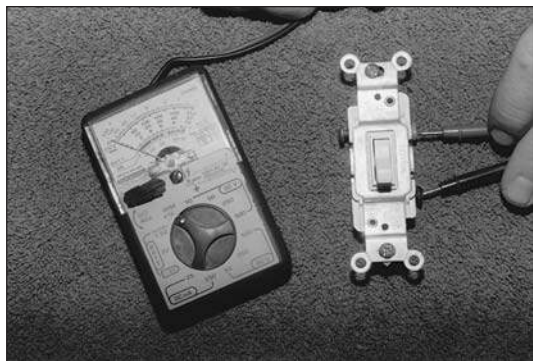

Attach the clip to the common screw terminal (the darker screw), and attach the probe to one of the traveler terminals. The switch is good if the tester lights up when the switch is in one position but not both. Attach the probe to the other traveler terminal and repeat the test, moving the toggle. This time, the tester should light up when the toggle is in the opposite position from the first test with the other traveler terminal.

New Switches

The easiest switch to replace is the single-pole switch. Before popping in a new one—and this is true with any device—read the specifications on the old switch. These usually are listed on the metal mounting strap and include the following:

- The amperage and voltage ratings
- The type of current it will carry (AC only for house current)
- The type of wire that's compatible with the device (CU for copper only, CO/ALR for copper or aluminum, ALR for aluminum only)
- Its Underwriters Laboratory or other testing service listing

The back of the device will indicate the acceptable wire gauge and a stripping gauge for measuring the amount of insulation to be removed prior to installation.

The location of your switch will determine how its replacement gets wired. A switch can be at either the middle or the end of a run (one complete circuit). These positions in the run are simply defined:

- A *middle-of-the-run switch* can be anywhere between the beginning and the end of the circuit. There will be at least two cables entering the box (at a minimum, one on the line side coming from the panel and one leading to a fixture or other device).
- In an *end-of-the-run switch* (also referred to as a “switch loop”), the cable runs from the fixture to the switch. This requires special treatment of the white wire.

The following figures show a middle-of-the-run switch and an end-of-the-run switch. Remember to shut the power off at the service panel or fuse box and to test the switch with a voltage tester before removing the wires. Note the condition of the ends of the wires. You don't want to reuse damaged or nicked wires. If you find any damage, cut off the minimum amount of wire necessary to remove this section and then strip off sufficient insulation (about $\frac{3}{8}$ of an inch) so the wire will make a solid contact.

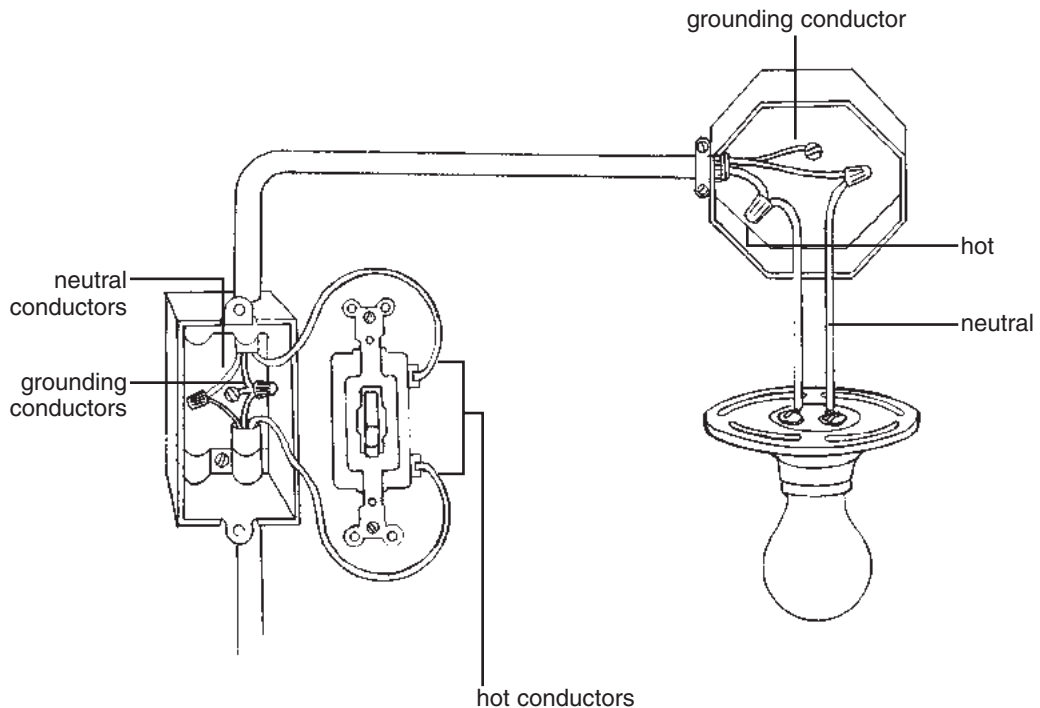

Middle-of-the-run switch.

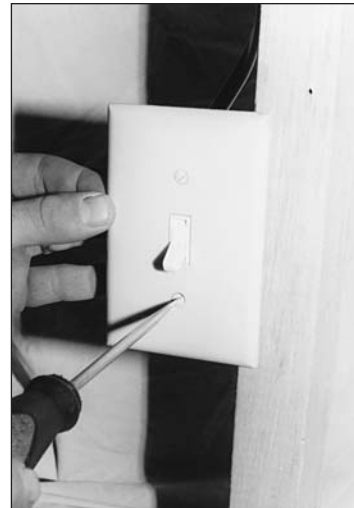
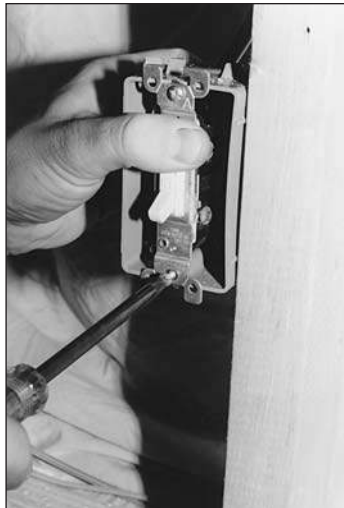
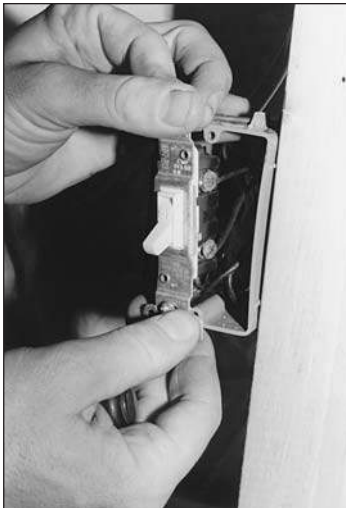
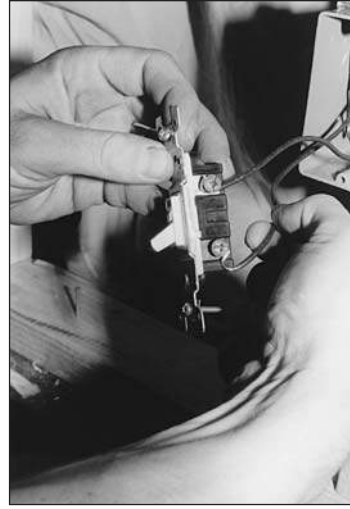
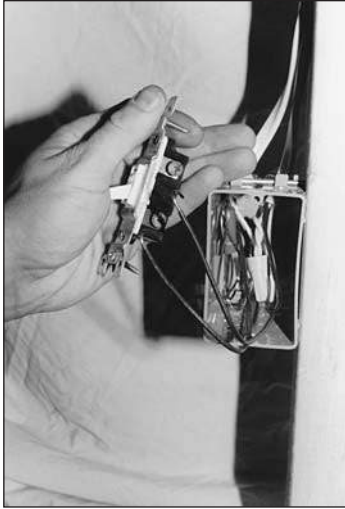

A middle-of-the-run switch: Loosen the terminal screws and carefully remove the black wires. Attach and secure the wires (hand tighten, but don't overtighten) to the new switch and install with the toggle in the "Off" position pointing down. (The black wires can go on either terminal screw.) Carefully tuck the wires back inside the box, pushing them to the side of the neutral wires as you mount the switch to the box. The mounting strap has two $\frac{9}{32}$ screws that insert into the box. Secure the switch to the box, making sure it's straight, and reattach the cover plate.

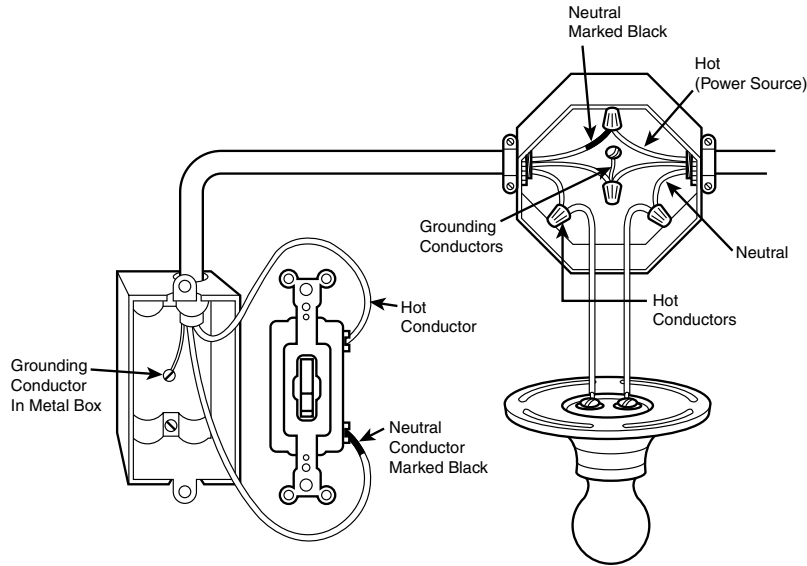

End-of-the-run switch (or switch loop): In this case, only one cable enters the box, and it's the one coming from the fixture. The white wire will serve as a black conductor, as shown in the following figure. The code requires that the white wire be the "hot" or phase conductor leading to the switch. That is, it will connect to the incoming black wire (the line conductor) in the fixture's electrical box. The black wire leading to the switch will be used as the load or switched conductor, which will run back to the fixture. To avoid confusion, you can mark the white wire with a small piece of black electrical tape so anyone looking at the switch in the future will know that both wires are hot.

Three-Way Switch

Replacing a three-way switch is more involved than replacing a single-pole variety. Now you have traveler wires to deal with (these connect the two three-way switches) as well as the common wires. This means the cable running between the switches is 12/3 (or 14/3) cable rather than the more common 12/2 (or 14/2).

Follow the same safety and testing procedures that you would with a single-pole switch. Because three-way switches (and four-way switches) are more expensive than a common single-pole switch, you want to be certain that the switch is really broken before throwing it away and replacing it.



Ask an Electrician

Cable is manufactured according to its gauge and the number of wires it contains. **12/2** is 12 gauge with one hot wire (usually black), one white or gray neutral, and a ground. **12/3** also is 12 gauge with two hot wires (one black and the other commonly red), one neutral, and the ground. 12/3 enables you to run one cable to various nonsequential devices.

A three-way switch; traveler terminals; traveler wires; common wire; common terminal; ground wires with jumper.

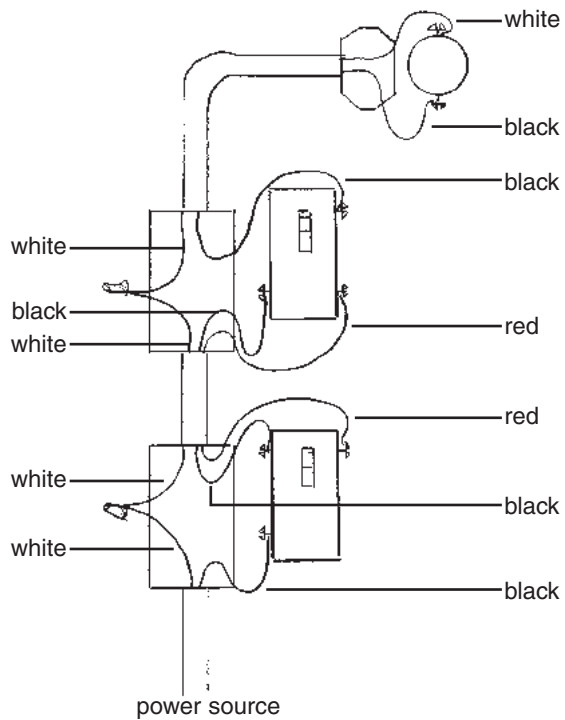
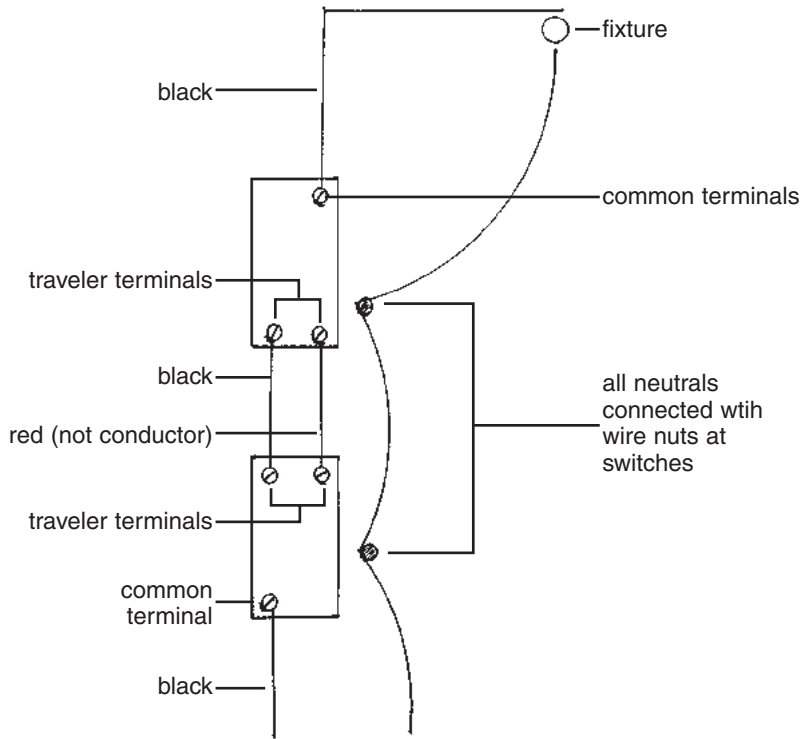

When removing a three-way switch from its box, note to which terminal screws or back-wired slots the wires are connected. Mark the common wire with a small piece of masking tape, or attach each wire to the new switch as you remove them from the old switch. The common terminal screw usually is copper; the traveler terminals are brass or sometimes silver. Note whether the neutral wire is being used as a hot conductor.

Four-Way Switch

A four-way switch has two sets of traveler wires running between it and a pair of three-way switches. There is no common wire nor is there a common terminal. The continuity test for a four-way switch requires a few extra steps. You need to put the clip on any pair of traveler screw terminals separately and then touch each of the other screws with the probe. This is a total of six tests for each position of the toggle (see the following figures). The test should show two continuous currents for each position of the toggle switch. (The paths between specific traveler screw terminals vary with different manufacturers.)

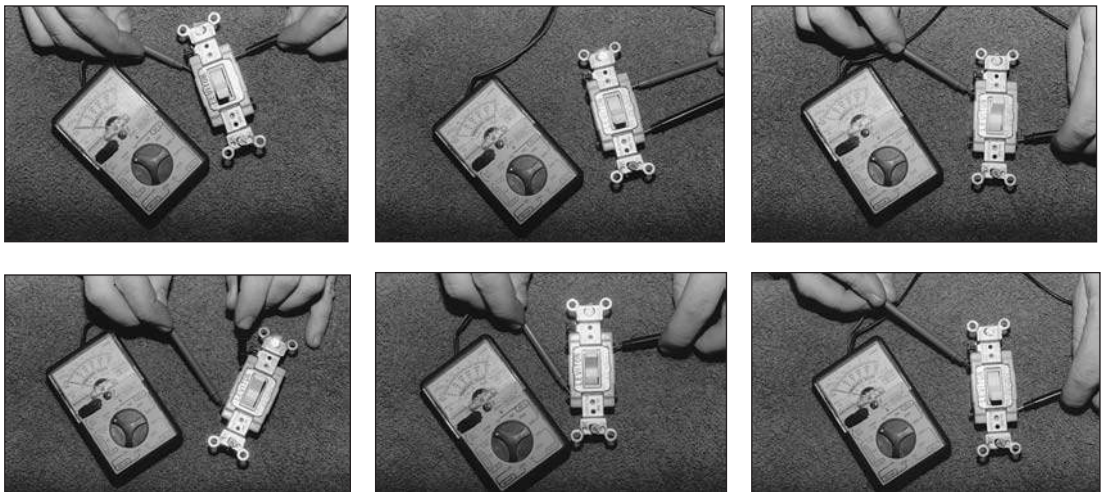

A four-way switch; 1, 2, 3, 4; testing screw terminals by pairs (1-2, 3-4, 1-4, 2-3, 1-3, and 2-4).

A four-way switch box has two cables with three conductors coming into it (thus four hot conductors or wires). Two are black; the other two are a second color, most likely red. When you replace the switch, be sure to match the wires to the correct traveler terminals. New four-way switches either match their terminals up by color (two are brass and two are copper), or the back of the switch might have wiring instructions. This makes your job easier. You simply have to match one color of wire insulation to one set of screws (red wires to brass screws, for example). See the following figures for a typical installation.

A four-way switch.

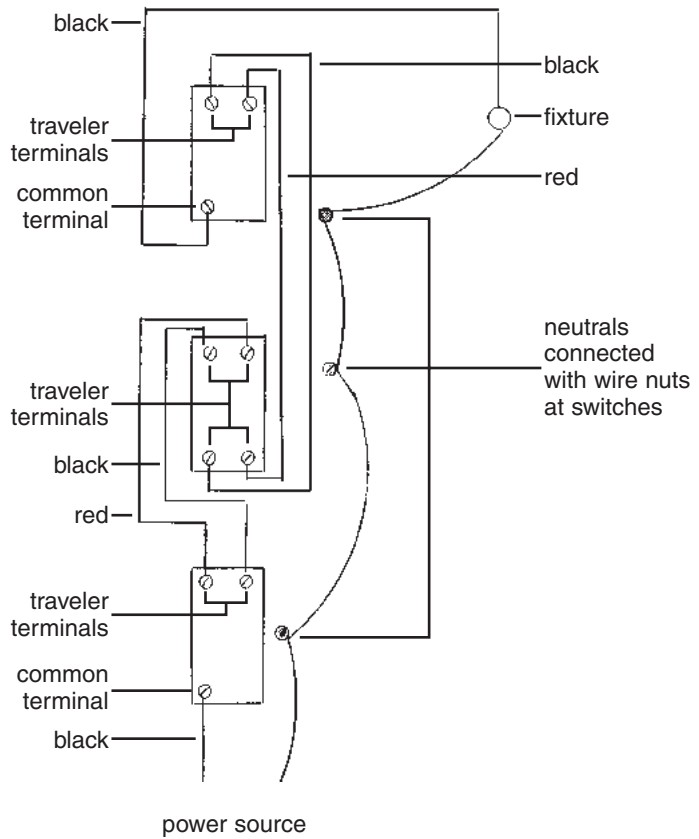
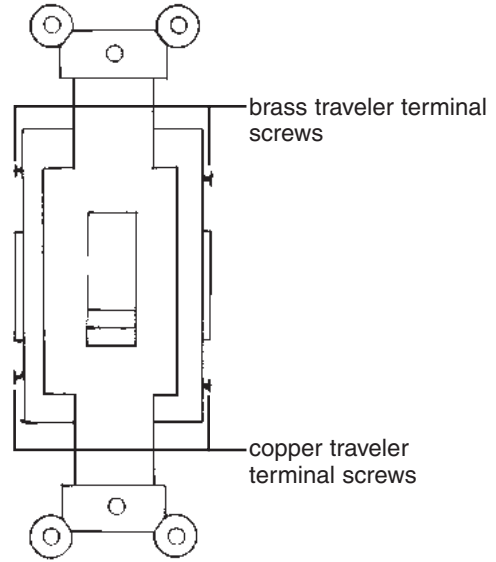

The Great Outdoors

You cannot replace an outdoor switch with an indoor switch unless you also use a bubble-type cover or a cover with a flip-style lid. These are weatherproof covers. Better yet, you can use a cover with a built-in, horizontal, lever-type switch that comes with a foam gasket between the cover plate and the box. The lever activates a regular toggle switch underneath. Other than that, the replacement procedure is the same as a regular single-pole switch.

Dimmers

You can replace any interior single-pole switch with a dimmer if the box is large enough to accommodate the larger body of the dimmer. Don't try to pack it into a tight or overcrowded box because this is a fire hazard (see the instruction sheet that comes with the dimmer). Dimmer switches come with about four inches of their own wiring or lead wires (line and load and ground wire) ready to connect with cable from the circuit with *wire nuts*.

Old Wire, New Switch

It can be difficult working with the deteriorated knob-and-tube wire ends inside a box. You might have to snip off the end, and the remaining wire can be a little too short to easily connect to a new switch or receptacle. In this case, you can pigtail a short, new piece of wire to the existing wire and connect the pigtail to the terminal screw on the device. This also will bring the wires into compliance with the NEC, which calls for six inches of workable wire length inside a box. The following diagram shows this type of pigtail.



Ask an Electrician

A **wire nut** (**Wire-Nut Ideal Industries, Inc.**), also known as a **solderless connector**, is a plastic, twist-on connector used to connect and protect wire ends that have been twisted together. Each size nut is color-coded according to its manufacturer and can only accommodate a certain number of wires.

*Knob-and-tube wiring
with pigtails.*



Disreputable Receptacles

Receptacles are pretty long-lasting, but old ones eventually can give out when the clips no longer hold a plug snugly. There also are drawbacks to some old receptacles if they're neither polarized nor grounded. Receptacle bodies also get broken if furniture or toy trucks somehow bang into them. (This happens at gyms all the time, only barbells do the damage.)

You want your receptacles and their cover plates to be intact. Broken or missing sections can set up you and yours for a shock or worse. When replacing an old receptacle, you can't simply pop a new, grounded receptacle into an existing two-slot outlet. It doesn't work that way, although there is a trick you can do with a GFCI that will give you some protection, but it will not ground any equipment plugged into the receptacle. A GFCI does not give grounding protection unless a grounding conductor already is present.

Check and Check Again

Receptacles, like switches and fixtures, need to be checked with a voltage tester before you do any work on them. The test is similar for both grounded and ungrounded receptacles, except you'll be testing for grounding as well with the former. A grounding test can only be done with the power on.

With the power off, insert both ends of your voltage tester into the slots of the receptacle. The light in the tester should not go on. If it does, the power has not been turned off, or the wrong circuit was shut off. Even if the tester bulb does not light up, you can't be sure that the current is off. The receptacle might be damaged but still receiving a current.

Remove the cover plate and carefully pull the receptacle out. Place one probe on the brass terminal, which should be connected to the black or hot wire. Place the other probe on the silver or neutral terminal. You must touch both terminals to complete the circuit. The bulb shouldn't glow if the power has been shut off.



Positively Shocking

Be sure to install a correctly rated receptacle when you replace an existing one. Most will be 15 amp. Installing a 20-amp receptacle on a 15-amp circuit can lead to overloading and can be a fire hazard.

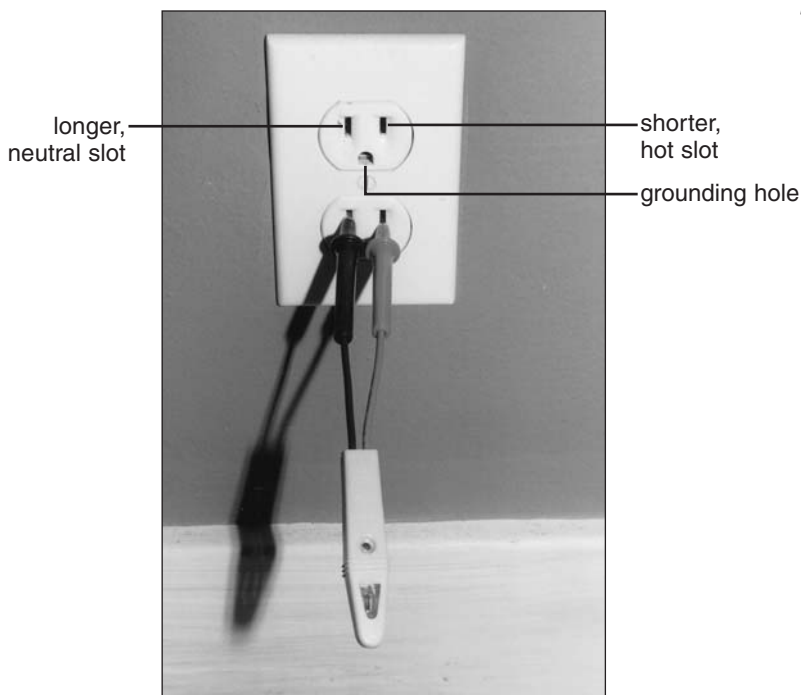

Testing for grounding.

Test for Grounding

You can test a grounded, three-slot receptacle for grounding (remember, the power is on) by placing one probe of your tester in the short slot and one in the hole for a plug's grounding pin. The short slot is for the hot wire. The bulb should glow to indicate that the receptacle is grounded. If it doesn't, keep one probe in the grounding hole and place the other one in the longer, neutral slot. In this position, if the bulb glows, it shows that the receptacle is grounded, but the black and white wires have been reversed (they're attached to the wrong terminal screws) and should be corrected. If the bulb doesn't glow in either case, the receptacle isn't grounded.

A three-slot receptacle that isn't grounded is misleading and dangerous to a user. It might indicate that only the individual receptacle is incorrectly wired or that it was inadvertently used to replace an ungrounded receptacle. Either way, you want to know so you can correct the problem.

Testing for grounding; the shorter, hot slot; grounding hole.

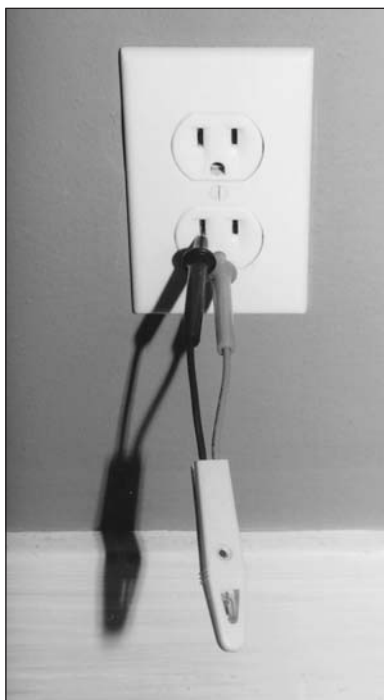

Two-Wire Grounding

Do the following to test a two-slot receptacle:

- Place one probe in the hot slot and the other end on the screw securing the cover plate. The screw must be clean as well as paint and grease free.
- If the receptacle is grounded, the tester's bulb will light up.
- Put the probe in the neutral slot if the tester does not light up in the hot slot. If it lights, the receptacle is grounded, but the neutral and hot wires have been reversed and are attached to the wrong terminals. If the bulb doesn't glow at all, the receptacle isn't grounded.
- To be absolutely sure that the receptacle is grounded (if your test indicates that it is), turn the power off and remove the cover plate. Check to see if an actual grounding conductor is present.

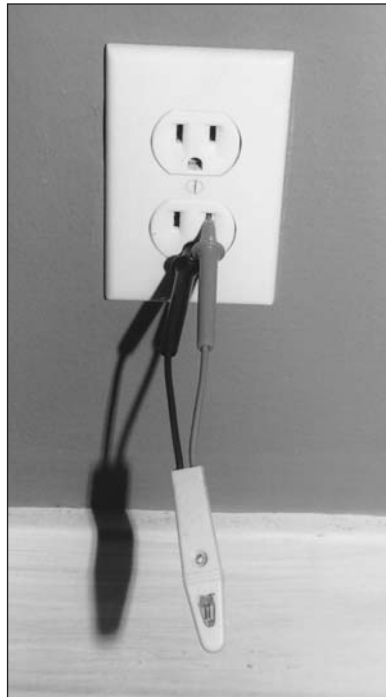

Testing a two-slot receptacle for grounding.

Installing a New Receptacle

Receptacles are a little more straightforward than three- and four-way switches. With a single duplex receptacle, you're dealing with one or two cables coming into the box. An end-of-the-run receptacle will have one cable, and a middle-of-the-run will have two. The receptacle has two sets of terminal screws, silver for the neutral wires and brass for the hot.

After shutting off the power and testing the terminal screws, remove the outlet by loosening the screws attaching it to the box. Remove the hot and neutral wires, noting their position on the outlet (hot upper, hot lower, neutral upper, neutral lower) by marking the position on an attached piece of masking tape. Reconnect to the new receptacle in the same locations, and gently push the wires back into the box while reattaching the new receptacle. Turn on the power at the service panel or fuse box and test.

Note the wire locations on the receptacle.

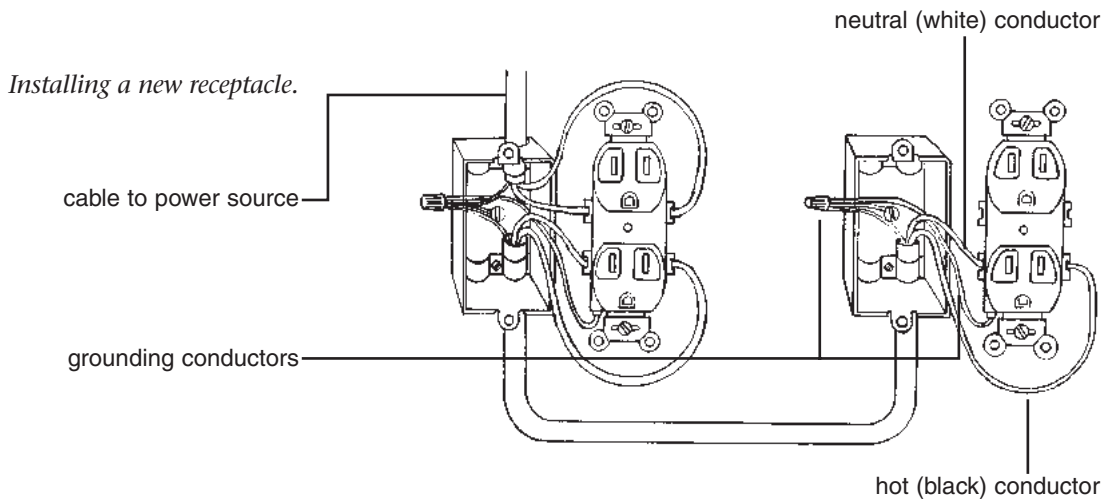
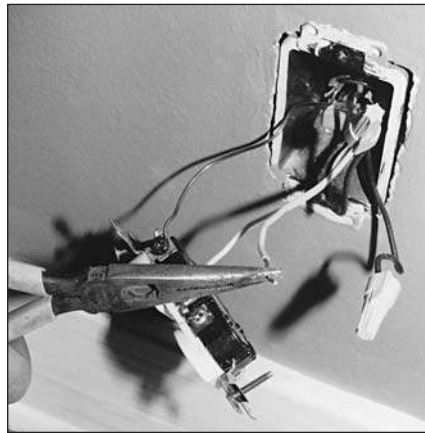

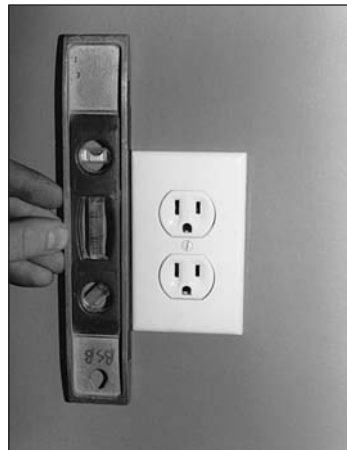
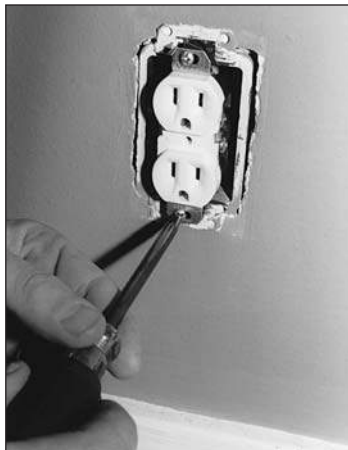
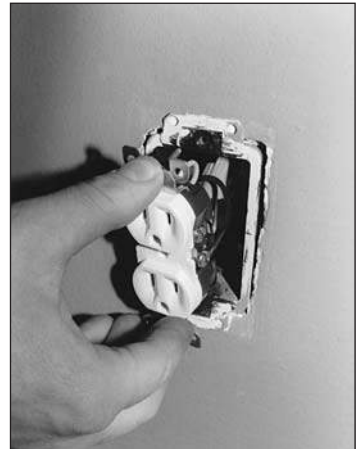
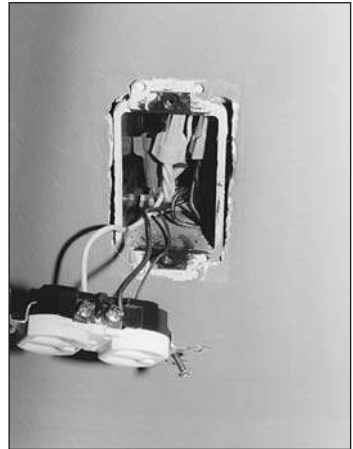
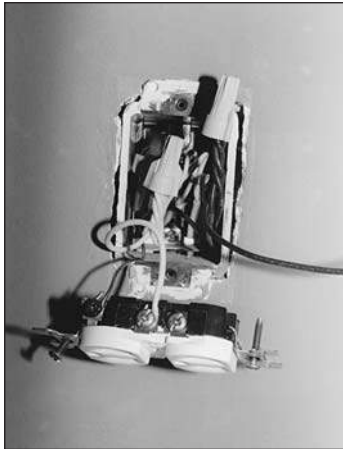
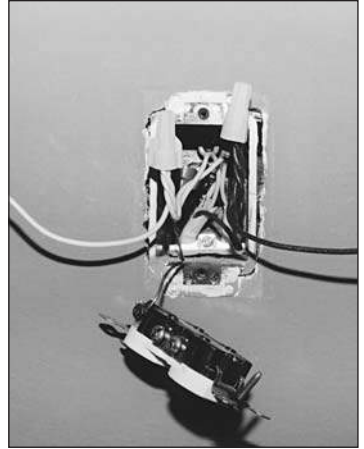
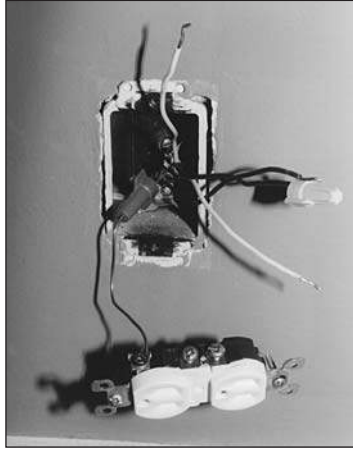
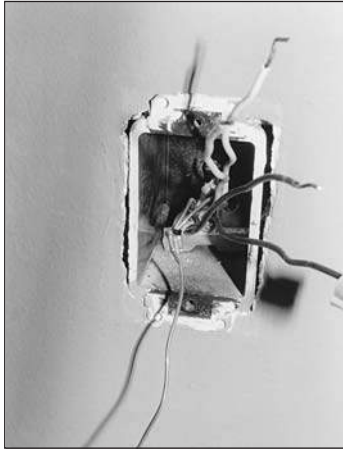

Grounding an Old Receptacle

A properly grounded system ties each device, appliance, and fixture back to the service panel with a separate grounding conductor (the bare copper or green insulated copper wire). It's unrealistic to attempt this with an old electrical system unless you're replacing it (in which case, the grounding would be part of replacing the system).

You also could install a GFCI in place of an existing, two-wire receptacle.

The National Electrical Code allows an ungrounded, two-wire receptacle to be replaced with a GFCI. A GFCI can even protect any receptacles downstream (away from the panel or power source). A GFCI used in this manner will only protect you from ground faults; it will *not* act as a ground for any equipment plugged into the receptacle(s). As a rule, it's best for GFCIs to protect only a single box, not multiple receptacles. If you try to use one GFCI to cover multiple receptacles, you might experience nuisance tripping due to the greater sensitivity to current fluctuations. A GFCI installed to replace a two-wire receptacle should be marked "No Equipment Ground."

A GFCI must be wired according to stamped terminals on the back of the receptacle. They will be marked "Load" and "Line" as well as "Hot" and "White." The hot wire (which runs from the panel or fuse box) is the line conductor; anything going off to another load or receptacle is the load conductor. How do you know which is which? You'll need your voltage tester.

With the power off and the old receptacle removed, separate all the wires in the box so they're not in contact with each other (or with the box if it's metal). Turn the power back on, and put one end of your probe on one hot wire and one on the neutral that is paired with the hot you are testing. If the bulb doesn't light up, try the other black wire and neutral. The one that lights up the tester's bulb is the line conductor. It's the one receiving power from the current you switched back on at the service panel or fuse box. Connect this to the "Line," "Hot" side of the GFCI. It is very important that the line side hot and neutral conductors or wires be connected to the "Line" side of the GFCI; otherwise, the GFCI will trip or will not work at all. If the line and loads are reversed, the GFCI will still have power if it is tripped, producing a hazardous situation.



Positively Shocking

Remember, a GFCI is used in places such as bathrooms to control dangerous electricity and possible shock. If you wire a GFCI incorrectly, it will not protect you. There is nothing more dangerous than thinking you're protected when you're not.

As an alternative to installing a GFCI to replace an ungrounded receptacle, it is permissible to install a grounding conductor to an ungrounded circuit by using an individual No.12 insulated green copper conductor to connect each receptacle being grounded to the closest cold-water pipe. The grounding conductor will then have to be secured to the pipe using an approved clamping device. It also can be run directly back to the panel and installed in the grounding/neutral bar.

A GFCI.

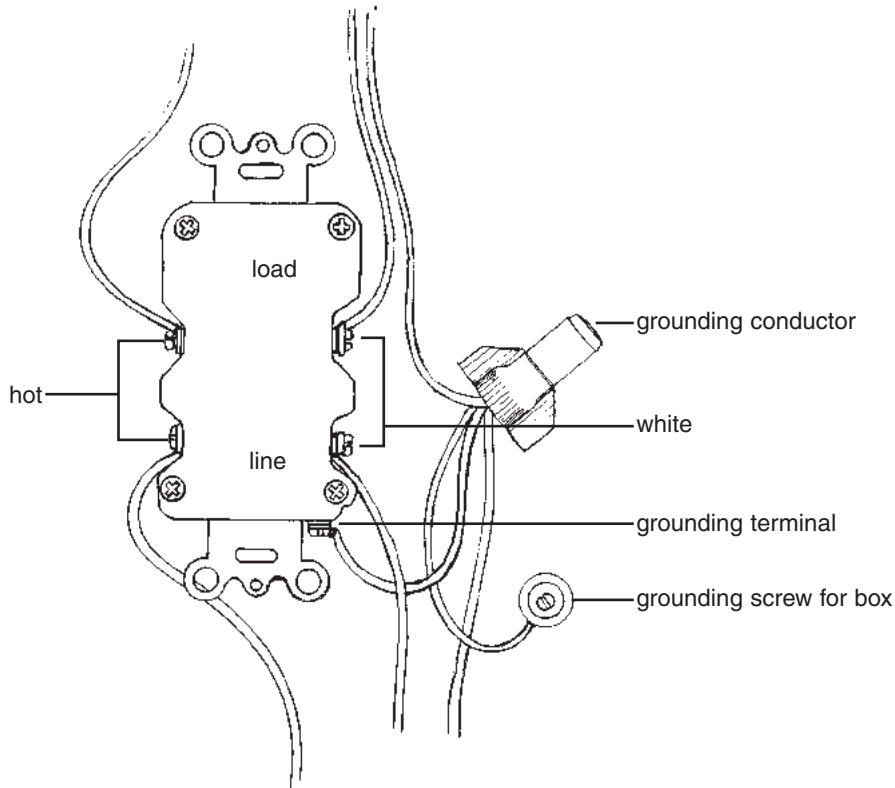

Aluminum Wiring

Aluminum wiring now requires receptacles and switches marked CO/ALR (see Chapter 6, “When You Buy a House”). Do not use any unmarked devices or devices marked CU or CU-CLAD ONLY. You must wire-brush the connections and apply an antioxidant paste to the ends of the wires before connecting them to the terminals.

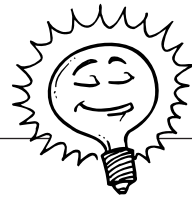

Bright Idea

It's easier to install a plug-in GFCI directly into your existing two-wire receptacle than to install a GFCI. Consider this option before replacing your old receptacles.

The Least You Need to Know

- Before replacing any switch or receptacle that you think is defective, make sure you don't have a problem somewhere else in the circuit.
- Even if you've turned off the power to a device, check it again with a voltage tester.
- Make sure the existing wiring pattern is correct for grounding and polarization before repeating it with your new receptacle.
- A GFCI can be installed in place of a receptacle without a ground. It will protect you, but it will not ground anything plugged in to the receptacle.



Lighting Up

In This Chapter

- ▶ Figuring your lighting requirements
- ▶ Different needs, different lights
- ▶ Work, mood, and ambient lighting
- ▶ Outside lights

Before Thomas Edison came up with a working light bulb, we burned different substances to provide us with light. We burned candles, oil, and kerosene until the late 1800s, and in some urban areas, natural gas was used into the 1920s. Using small flames as a source of work and reading light left something to be desired. (The traditional lighting of the Christmas tree occasionally burned down the house.)

The advent of electric lighting changed our lives forever. Workplaces have become safer and so have our homes. We are less dependent on natural lighting, so productivity has increased dramatically. On the downside, because we can now wander around the house at all hours of the day and night and see where we're going, we sleep less than ever before.

Today we have a vast array of lighting options to choose from for our homes. From a basic incandescent lamp to the newest halogen fixtures, we can light up every corner and do so with timed switches, dimmers, or a standard toggle switch from multiple locations. This chapter introduces you to some of these choices and how they can affect your electrical remodeling or additions to your system. There really is life after your vintage 1960s ceiling fixtures, but you might want to hold on to the lava lamps.



Ask an Electrician

Light is a form of radiant energy made up of electromagnetic waves of different wavelengths. The rods, cones, and optic nerves in the eye's retina react to light's electromagnetic waves, resulting in vision.

How Illuminating

We are way beyond the point when lighting was simply functional, allowing us to work and not stumble around after the sun went down. If function was all it meant to us, every room in our house would have one huge, efficient, fluorescent light fixture on the ceiling and maybe a night-light or two for after dark. Instead, lighting does much more such as ...

- Create a mood or atmosphere.
- Define a space.
- Provide security and safety.
- Highlight artwork or a section of your home.

Your lighting needs will be defined by these factors and others. Before you install a particular type of lighting, ask yourself the following questions:

- Who will be using this area and for what purpose?
- Do I want a traditional or modern look?
- How often will anyone be in this room?
- How much am I willing to spend?
- Is energy conservation important to me?

At a minimum, the code calls for one switch-controlled light per habitable room. Hallways, stairways, and garages also must meet this code requirement. This can be accomplished with permanent fixtures, such as ceiling lights, or through a switch-controlled receptacle into which a lamp can be plugged. Bathrooms and kitchens, however, must have an installed fixture. Your first step is to establish your minimum lighting needs and then choose the style of fixture you want to meet them.



Electrical Elaboration

Despite Edison's introduction of the incandescent lamp, it would be years before electrification was prevalent around the country. Builders eventually began installing wiring in homes even if electricity wasn't available in the immediate area. As a backup to unreliable electrical generation, both gas and electric lighting were installed in new homes in some locations until around 1920. Homeowners wanted the assurance of gas if the power went out for an extended period of time.

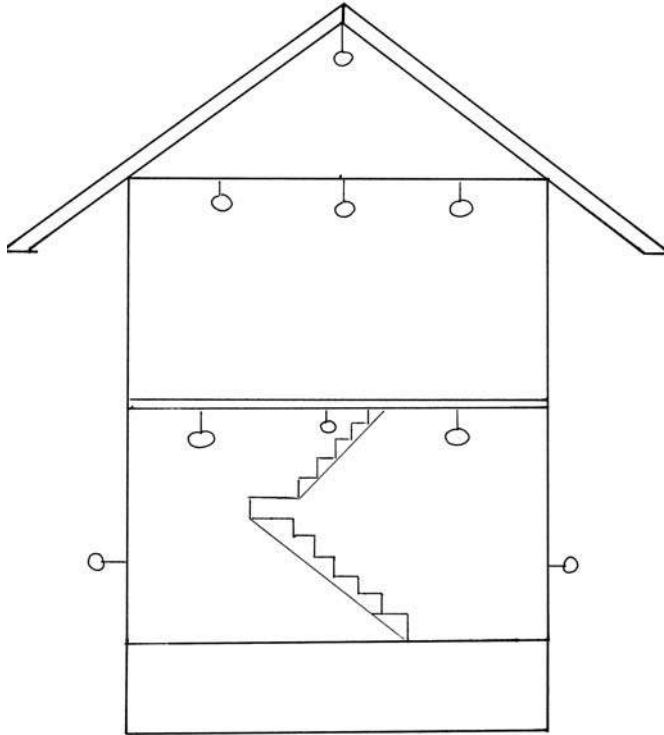

Typical locations of switch-controlled lighting; Required at:

Outdoor entrances.

Basements (all finished rooms, stairs, and storage areas or rooms with HVAC or water heaters which may require maintenance).

First floor: all living space (cannot have switch-controlled receptacle in bathrooms or kitchen).

Second floor: all living space and stairs.

Third floor/attic: if finished or used for storage.

Garage: inside, but not mandated for exterior.

Measuring Your Lighting Needs

The NEC calls for a minimum calculation for general lighting and receptacle loads of three watts per square foot of living space. This comes out to approximately one circuit every 575 square feet. That doesn't amount to a lot, but remember, electrical codes only establish minimum standards. In reality, you'll want lighting everywhere. Consider the different areas of your house and their individual needs:

- **Kitchen.** Overhead lighting, natural light from windows and sliding doors, work light over counters, a light over the stove.
- **Bathrooms.** Primarily lights over the sink(s) and lights over the bathtub and toilet, depending on the size of the room.
- **Dining room.** A hanging light over the table, recessed ceiling lights, or possibly wall sconces. This room often has a dimmer switch to tone down the light.
- **Bedrooms.** Children's rooms often get ceiling lights. Master bedrooms might depend more on reading lamps and switch-controlled receptacles, although large rooms can use recessed ceiling lighting as well.
- **Hallway.** You might want a long track light to highlight artwork on the walls.

- **Garage.** At least one light per bay over the hood of the cars. It's even better to add one or two at the other end so the trunks are illuminated.
- **Basement.** Depends on whether the space is finished or unfinished. In either case, you want at least enough ceiling light to cover the entire area thoroughly, leaving no dark spots.
- **Closets, storage rooms.** At least one ceiling light.
- **Outdoors.** At a minimum, one light over each entry door and over the garage doors. It's even better to consider lights to line walkways and illuminate gardens or security lighting for back and side yards.

Your use of a room obviously will determine your choice of lighting fixtures, their locations, and their number. A single fluorescent ceiling light will fulfill all the working requirements of most closets because the requirements are pretty basic: to shed enough light for you to identify and choose your clothes. A kitchen, on the other hand, requires all kinds of light for a modern homeowner. You need lights over counters for close work so you can chop, dice, and mince vegetables instead of your fingers. Overhead lights enable you to read the newspaper and get a better look at what's hiding in the back of your pantry. A dimmer-controlled hanging light over the eating area lets you tone things down for a late-night meal.

Anywhere you've got a wall, ceiling, or floor, you can install a light. It's simply a matter of extending a circuit or running a new one and choosing your fixtures. The science of lighting is a little more complicated.

Distinguishing a Lumen from Illuminance

Light output is measured in lumens. According to *The American Heritage Dictionary of Science*, a lumen is a unit of luminous flux equal to the amount of light from a source of one candela radiating equally in all directions. A candela is a unit of luminous intensity equal to $\frac{1}{60}$ of the radiating power of one square centimeter of a black body at 1,772°C. You can draw two conclusions from this information:

- The higher the lumen measurement, the more light you'll have to work with from a fixture.
- Authors can easily get carried away when they have too many reference books at their disposal.

Illuminance, which is measured in foot-candles, is the amount of light hitting a point on a surface. A foot-candle is (easily enough) defined as the amount of light produced by one candle on a surface one foot away. We can't see illuminance, but we do see luminance or brightness, although this is somewhat subjective. (What appears to be dim light to me might be plenty bright to you.) Architects and lighting consultants take all these measurements into consideration when they calculate the lighting needs of buildings.

Comfortable lighting selections and light levels are determined by the tasks that require the lighting, the distance between the light and the task, and the degree of glare. One definition of glare is excessive contrast between the intensity of light on a particular object or surface and the surrounding area or background; indirect glare is the glare produced from a reflective surface. Too much contrast between them causes glare. (Computer screens are a common example.) You can reduce this glare by ...

- Installing fixtures that keep the light level appropriate for the task at hand.
- Using a louver or a lens to block or redirect the light.
- Carefully considering the placement and spacing of light fixtures.

Another measurement of lighting quality is how well it enables you to see colors accurately. The better the color rendering, the more pleasing the living space. Color-rendering capability is based, naturally enough, on the color-rendering index (CRI), which measures from 1 to 100. (Natural daylight measures at 100.) The higher the rating on the CRI, the more lifelike and accurate the object being viewed.

Know Your Lighting

Lighting is defined by its use in our homes and places of work. Designers and architects break it down into several categories:

- **Accent lighting** emphasizes or highlights a specific area or object and directs our attention to it.
- **Ambient lighting** is general illumination.
- **Task lighting** is for illuminating work and tasks.

It's never a bad idea to install plenty of ambient lighting, even if you later decide it's more than you immediately need. At some point in the future, you might move things around and decide you need more lighting. I wouldn't recommend tearing up

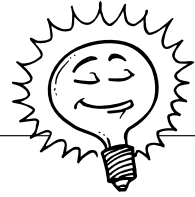

Bright Idea

When determining your lighting needs, keep in mind how reflective the various surfaces in a room will be and how much daylight is available. Dark-green carpet won't reflect light the way white vinyl flooring and countertops will. Too much light is just as much a problem as too little light.



Positively Shocking

Never use a higher-wattage light bulb than a light fixture can handle. This can lead to overheating and possibly a fire. Instead, install fixtures that can handle a higher wattage than you need so you have the choice of using either the higher- or lower-wattage lamps.

the walls just to install fixtures, but if you have an open ceiling or already are doing some installations, consider a few extra light fixtures if the circuit permits.

If you walk into a lighting store or the lighting section of a home-improvement center, you'll see dozens and dozens of fixtures to choose from. Where do you start?

Aim High, Low, and Wide

Light from a lamp is aimed somewhere, whether it's the top of your desk or your workbench. Even general ambient lighting gets directed somewhere. Recessed ceiling lights and adjustable spotlights can provide as broad or as focused a beam of light as you desire. Some lights are installed as wall washers, meaning they shine down a wall either to highlight artwork or other collections or simply to draw your attention to the perimeter of the room, conveying a greater sense of size than might truly exist. The advantages of recessed ceiling lights are their versatility and unobtrusiveness. Let's face it, a chandelier automatically draws attention to itself—especially if one of your party guests is swinging on it. A recessed fixture is far more subtle and almost hides in the background.

Some fixtures can serve more than one purpose. A wall sconce, for example, can serve general, task, and accent lighting needs. This versatility is a huge advantage over ceiling lights when you're remodeling because it's far easier to wire and install a wall fixture than to install most ceiling fixtures.

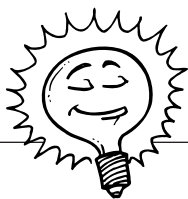

Bright Idea

For bedroom reading lights, consider a halogen lamp by the bedside. This will give out a very focused, narrow light rather than filling the room the way an incandescent lamp will. A narrow light will be less disturbing to a sleeping spouse.

Lighting Up Outside

I think exterior lighting is always a plus with any home (see Chapter 21, "The Great Outdoors"). Good lighting will welcome you and your guests on a rainy night, provide some measure of security for your family, and illuminate address numbers, door locks, and staircases. Before you decide to install fixtures as powerful as Batman's searchlight, consider the following:

- Know the size of the fixture and its scale compared to your house.
 - Think about the location and aim of the lights and their effect on your neighbors. (A little light goes a long way at night.)
 - Caulk the top seam between the fixture and the section of the house where it's attached to ensure that water stays out. Leave the bottom uncaulked so that, if moisture does get in, it has a place to exit.
- Think twice before installing solid-brass fixtures. They won't rust, but eventually most will tarnish and need polishing.



Outdoor path light.
(Progress Lighting)



Outdoor pagoda light.
(Progress Lighting)



Electrical Elaboration

In some instances, outdoor lighting can be dangerous to wildlife. In parts of Florida and other coastal areas, residents and businesses are asked to turn off their bright lights during certain cycles of a full moon because the lights can confuse sea turtles who see them as a signal to come ashore and lay their eggs.

Installing outside lighting, like many tasks, can be done the easy way or the hard way. The easy way means mounting all the fixtures on the walls of your house (and porch ceilings), which means you can pull your wires from inside the house. The hard way means digging ditches and running wires and conduit underground, although this will give your yard a much more dramatic presentation. As a final consideration, think about what your outdoor lighting will look like from *inside* the house. You can enjoy your yard even in the winter if you set up lighting that accents it well.

Combining Lighting Styles

Most general living space will accommodate more than one lighting style. A closet obviously doesn't need accent lighting unless you make a point of giving your guests a tour of your shoe collection. A dining room needs ambient light, but it can become very dramatic with, say, floor-to-ceiling lights illuminating the side walls while the recessed ceiling lights are off and a few lit candles are on the table. A mix of lighting offers the most options and can present a room and its occupants at their best in a variety of settings.

Whether you're building something new or remodeling, keep your furniture in mind rather than strictly installing lights by formula (so many per square feet at such and such a distance from each other). You might have a grand piano ready to nestle in a corner of the living room or a windowless wall just waiting for your collection of family portraits. Either situation calls for very specific fixture placement.



*Close-to-ceiling
incandescent.
(Progress Lighting)*



*Close-to-ceiling compact
fluorescent.
(Progress Lighting)*



*Sconce.
(Progress Lighting)*

Track lighting.

(Progress Lighting)



Semi-flush style.

(Progress Lighting)



Chandelier.

(Progress Lighting)



Looks Are Something

The cheapest porcelain fixtures with 100-watt bulbs might provide safe lighting, but they won't be much to look at. Visualize the appearance of the fixture and the lamp as well as their function. Some fixtures literally are works of art (Tiffany lamps, for example); others are designer-created and are very striking to look at. Do you want to look at a brass hanging light over the kitchen table or cobalt-blue steel? You're going to be looking at them every day, so take your time choosing your fixtures.

What's Your Type?

Lighting is divided by the type of lamp used and the style of the fixture. Lamp types include ...

- Incandescent.
- Fluorescent.
- Halogen.

Each of these has distinguishing characteristics, as described in the following list. When it comes to fixture styles, the sky's the limit. They range from antique reproductions to one-of-a-kind works of art (with prices to match). The following are some of the most common light fixtures:

- Flush-mounted ceiling lights that include square, mushroom, or round domes
- Hanging ceiling lights and chandeliers
- Surface fluorescent lights
- Recessed ceiling lights
- Track lighting
- Bath bars
- Sconces and wall-mounted lights
- Wall washes
- Undercabinet-mounted lights

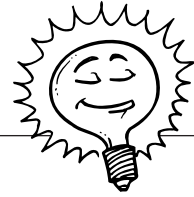

Bright Idea

Consider installing adjustable recessed fixtures so the light beam can be aimed in different directions as your decorating changes. This is less expensive than trying to install additional fixtures.



Ask an Electrician

Although we commonly use the term "light bulb," the more accurate term is **lamp**. A **bulb**, as my technical editor has pointed out, is something you plant in the ground. The complete lighting unit (lamp, lamp socket, housing, reflective material, lenses, and, when called for, ballast) is called a **luminaire**. I use the term "lamp" where possible in this book. Where I must, I use the word "light bulb" for clarity.

- Outdoor lights (floodlighting, landscape lighting, pole-mounted lights, wall-mounted lights, and security lighting)

All of these will light up a given area. You just have to decide whether they will provide light that you find both appropriate and pleasing to the eye. Your budget also is a consideration, especially if you're buying fixtures for a major remodel. An outdoor landscaping light, for example, can be a simple pagoda light or an ornate—and expensive—leaded-glass lamp. (The latter is not recommended if you have kids, dogs, or errant adults running around the yard.)

Incandescent

This is the most familiar type of lamp. An electric current passes through and heats a tungsten filament, producing a glowing light. (The term “incandescent” literally means “to glow or become hot.”) Over time, heat evaporates the tungsten, and it eventually weakens and breaks. The lamp contains a chemically inert gas that allows the tungsten vapor from the heated element to deposit on the sides of the glass. This is why standard incandescent lamps gradually become darker over time. If they are too small, the tungsten coating would turn them opaque, and they'd be useless as a source of light.

Incandescent lamps are cheap to produce and are versatile in application, but they are considered to be impractical by energy conservationists as a source of light given modern alternatives. They produce a considerable amount of waste heat for the amount of current they draw, and they have a useful life of 750 to 2,500 hours depending on the lamp. Builders traditionally install incandescent fixtures because both they and the lamps are inexpensive and are not likely to meet any resistance from price-conscious buyers. When buying lamps, take note of the voltage rating of the lamp. Typical lamps sold in stores are rated at 115 or 120 volts. At professional lighting stores, you should be able to find longer-lasting lamps rated at 130 volts.

Tungsten-Halogen Lamps

These lamps (which are smaller in size than standard incandescent lamps) also heat up a tungsten filament, but they contain halogen gas. The gas combines with the evaporated tungsten to create tungsten halide gas that deposits the tungsten back onto the filament, extending its life. After the deposit, halogen gas is released and the process starts all over. The smaller size of the lamp enables the filament to heat up to a higher temperature and a higher efficiency.

Because none of the tungsten is deposited on the glass, a halogen lamp burns brighter and has a very focused, intense light.

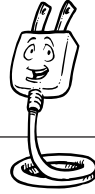

Electrical Elaboration

Halogen lamps operate at high temperatures. Halogen lights designed for installation under kitchen cabinets can be tested to UL standard 153. This is a safety standard that says the wood above the lamp must have a temperature lower than 194°F or 90°C with the lamp on. Halogen lamps used inside china cabinets (or other cabinets used for display) also must pass this test to get this UL rating.

Fluorescent Lighting

Fluorescent lamps are considered to be the most energy efficient, but they often suffer from a reputation as flickering, eerie sources of light suitable only for institutional settings. They are the light source of choice in industrial and commercial settings because of their efficiency and long life—something worth considering for your home as well. Modern fluorescent fixtures have a place in residential settings.

A fluorescent lamp is constructed with ...

- A glass tube.
- Argon or argon-krypton gas and a small amount of mercury.
- *Phosphor* coating on the inside of the tube.
- Electrodes at each end of the tube.

As electricity passes between the tube's electrodes, it jostles the mercury atoms, which then give off ultraviolet radiation. The radiation is converted to light when it interacts with the phosphors lining the tube. The fixture itself comes with a ballast to kick-start the current passing within the tube and to keep it regulated. The range of phosphors available to manufacturers enables them to produce lamps with different color tones for different applications. Fluorescent fixtures also produce less heat and more light for the amount of electricity they consume as compared to incandescent lamps.



Ask an Electrician

Phosphor is a phosphorescent substance. **Phosphorescence** refers to the light given off when a substance absorbs certain types of rays such as ultraviolet rays.

One of the biggest changes in fluorescent technology is the shape and size of the lamps. In the past, you were stuck with straight, U-shaped, or circular figures. (The last always seemed to be used outside small-town, drive-in, ice-cream stands for some reason.) Now we have compact fluorescent lamps that can be an efficient substitute for incandescent lamps. A 40-watt compact fluorescent lamp, for example, can replace a 150-watt incandescent lamp and can last up to 10 times longer. (It had better, given the typical cost of \$20 or more.) Two types of replacement units are available:

1. Integral units, which include a compact fluorescent lamp and ballast in a self-contained unit
2. Modular units, in which the bulb is replaceable

Now you know that you can replace your incandescent lamps with compact fluorescent lamps, but is it worth it?

When Cheap Power Reigns

At one point in the 1980s, it was estimated that the cost of residential electricity in Seattle was one tenth the cost in New York City. If it's any consolation, our delicatessens weren't anything to write home about. The cost differential isn't that great anymore, but we're still below the national average. Lower costs aren't necessarily a justification for excessive use of electricity, but they will determine whether more efficient fluorescent lamps will ever pay off for you.

Basically, the higher your electricity costs run beyond the national average (around 8¢ per KWH), the more cost-effective fluorescent lights will be in your home. This doesn't mean they will work well for all your lighting needs from a cost standpoint. The longer a light is continually on, the better a candidate it is for a fluorescent lamp. An occasionally used attic or storage-room light is best left with an incandescent lamp. Some fixtures, such as recessed ceiling lights, might not have room for a fluorescent lamp.



Electrical Elaboration

Keep in mind that adding windows also will affect your overall energy costs, probably even more than the amount of light you'll be saving by using natural daylight versus electric light. Nevertheless, it's hard to put a price on the advantages and the appeal of natural light, especially during the winter months. Look at all factors before ruling out additional windows.

Other Considerations

The most comfortable light in many instances is natural sunlight. (You may think differently if you live in the Sahara desert.) If you're remodeling or adding on to your house, think about adding more windows and skylights. Millwork companies can custom match any existing wood window or come close enough with stock material. There are enough vinyl and aluminum window manufacturers around that you should be able to find one that will look like part of your house.

Paint color also affects the impact of light, both natural and electric. Light colors will be the most reflective, but they might not be your first choice in certain rooms. Balance out your color choice with adequate lighting.

Finally, look at your choice of controls or switches. Dimmers are inexpensive, and they greatly expand your options in any room. One minute your living room is washed in light for your Scrabble club's monthly game; the next minute it's dimmed way low for you and your jo. (Scottish for "sweetheart," this word works great on a triple-word score.)

The Least You Need to Know

- Good lighting is more than just functional; it provides atmosphere, helps in your work, and adds highlights.
- Be sure to match your light fixtures and lamp choices with the lighting requirements you're trying to meet.
- It's hard to go wrong installing plenty of ambient or general-purpose lighting.
- Outdoor lighting should get just as much thought and attention as your indoor plans.
- Fluorescent technology has greatly improved over the years and is a good choice for residential lighting.

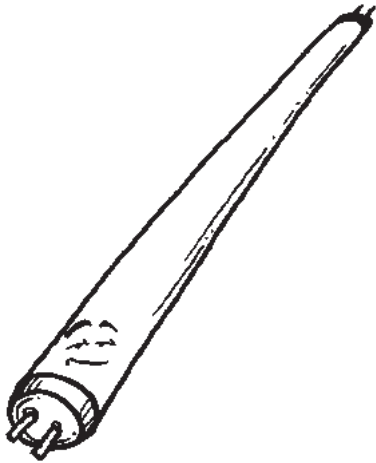

Light Fixes

In This Chapter

- Basic fixture replacement
- Fluorescent fixes
- Replace or repair?
- Cord and plug patches
- Finding the problem

Changing a light fixture can be more involved than simply replacing a switch or a receptacle. Switches and receptacles almost always are housed in electrical boxes, but this isn't always true for light fixtures. If the system is old or has been hacked at enough, you can disassemble an old ceiling light only to find a couple of wires dangling through the plaster without the hint of a box. As you should know by now, this is a dangerous situation because all wire connections must take place within a box. You might feel like cheating by continuing the status quo, but don't. You'll need to install a new box (unless one's already there).

Lights usually get replaced because tastes change. Old fixtures don't often wear out, since they have no moving parts (unlike a switch). Historic or not, the original hanging lights in your Craftsman home might be ugly to your eyes, or you might want to replace more modern fixtures with replication period fixtures to restore your home closer to its original condition.

The usual safety precautions apply to replacing fixtures that apply to any other electrical work—turning the power off is number one—but now you'll sometimes be working off a ladder. For that matter, two of you might be working off two ladders if you have to remove an especially heavy or delicate fixture such as a chandelier. One thing is for certain: With the huge selection of new fixtures to choose from, you're bound to find a replacement that will dress up any room in your house.

Inspect First

There are two main reasons for replacing a light fixture:

- It isn't working, and you believe it is somehow broken.
- You want to install an updated style or a fixture that will offer more light.

You should do a number of checks before pronouncing a light fixture broken or beyond repair. You already know about checking the switch and the fixture itself for power. In addition, you should look at the following:

- The lamp (light bulb)
- The socket
- The wire connections inside the box

Checking the light bulb is the obvious first course of action—replacing the bulb with one that's working. If it got jostled around in a storage drawer or even on the way home from the hardware store, there's always a chance a new bulb isn't working, so check it in a fixture or lamp you know is working. The next thing to check is the socket. At the bottom of the socket is a small metal tab that makes contact with the bottom of the lamp. Turn the power off and check with your voltage tester by placing one probe on the metal tab and one on the inside of the metal socket. The bulb should not glow. If it does, the power is still on, and you need to shut off the correct circuit. With the correct circuit shut off, test the fixture again with your voltage tester.

With the power off, pull the end of the tab up a little bit using the end of a screwdriver. Screw in the lamp, turn on the power, and try the fixture again. These tabs sometimes become depressed or flattened out and don't form a tight contact with the lamp.

Why would the contact suddenly be broken? All it takes is a slight vibration in the fixture from, say, a large truck passing by. If a light bulb that you know is good doesn't work, you have a problem with the socket. Remove the fixture to test the socket by following these steps:

1. With all glass globes, lampshades, and light bulbs removed, unscrew the fixture from the box by turning the mounting screws counterclockwise.
2. Carefully pull down the fixture and let it rest on top of the ladder. This is critical if it's a heavy fixture.

3. Disconnect the wires from the terminal screws and take down the fixture.
4. Attach the continuity tester's clip to the hot wire terminal screw, and place the probe against the metal tab in the socket. If the tester does not glow, the socket needs to be replaced.
5. Attach the continuity tester's clip to the neutral terminal and the probe to the threaded portion of the socket. Again, if the tester's bulb does not glow, the socket needs replacement.

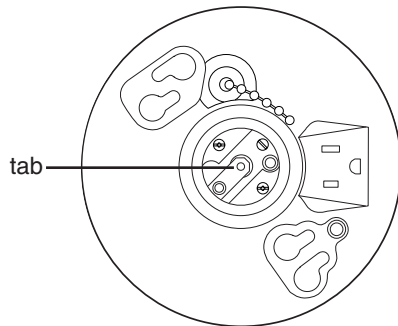

Pull up lightly on tab for better contact with bulb.

(Courtesy of Leviton)

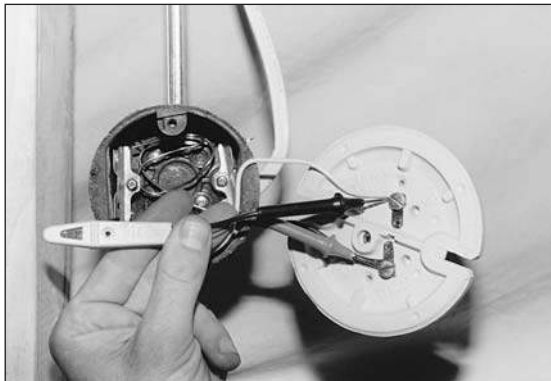

*A hot screw terminal;
neutral screw terminal; a
clip; a probe; a metal tab;
a socket.*

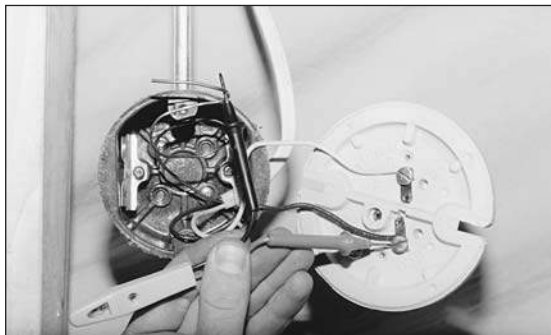

Some sockets are permanently attached to the fixture, in which case the entire fixture must be replaced. Others are attached to the fixture with screws and can be removed and replaced. Take your old socket to the hardware, lighting, or electrical-supply store and purchase an identical replacement.

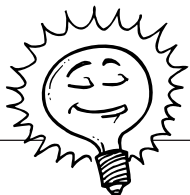

Bright Idea

Be sure to check for tight wire connections when you inspect your fixtures. Remove the wire nuts (or any tape) to confirm that the wires are making a solid contact. (If not, that's all you have to fix.) It's sure less work than replacing a fixture that doesn't need replacement.



Positively Shocking

Do not install a fixture of higher wattage unless the circuit can support it. Only install a lamp that is equal to or less than the wattage recommended on the fixture. (There will be a tag listing the wattage and voltage of the fixture.) A lamp of higher wattage will develop too much heat, which can damage the fixture and the wiring.

The same vibrations also can cause the wire connections to come loose just enough to lose contact with the fixture.

Time to Replace

Installing new fixtures is a doable homeowner project. It's easier to do with modern wiring and boxes, but it still can be done with older types of wire as well. To replace a fixture, follow all safety precautions, read the instructions and diagrams that come with the fixture, and ...

1. Turn the power off and test to make sure it's off.
2. Follow the preceding steps for testing the fixture's socket to remove the fixture and undo the wire connections.
3. If the fixture does not have an electrical box, install one (see the following section, "Installing a Box").
4. Install the mounting strap that comes with your new fixture to the box. (The strap, also called a mounting yoke, has predrilled holes set to the dimensions of the fixture.)
5. Connect the black wire and the white wire from the fixture to their counterparts in the circuit wires.
6. Connect the grounding wire to the grounding screw on the mounting strap and to the grounding conductor that might come attached to the fixture.
7. Install a light bulb, turn on the power, and test the fixture. After the test, turn off the power and remove the bulb.
8. Attach the fixture with its mounting screws to the mounting strap.
9. Install the light bulb and the globe.

Installing a Box

A self-supporting retrofit box can be installed in an existing ceiling or wall if your light fixture doesn't have a box. This regularly will be the case with very old wiring or poorly done additions to your electrical system. You'd be surprised how many old incandescent fixtures are attached directly to plaster lath instead of to any kind of box.

Retrofit boxes come in two flavors: metal and plastic. Each is designed to fit snugly against either plaster or drywall by using adjustable ears and brackets that expand and/or tighten against the wall. A plastic box has an attached, U-shaped bracket that tightens like a toggle bolt as its attachment screw is tightened. A metal retrofit box comes with brackets or supports (known as "Madison Holdits" and sometimes as "battleships") that fit between the box and the wall. As they are pulled out, they firm up the fit of the box. The arms of the supports are then bent over the edge of the box, tucked inside, and pinched tightly with pliers.

Another version of a metal retrofit box features a screw-operated support on each side of the box. As the screws are tightened, the metal support wedges the box in tightly against the plaster or drywall. A retrofit plastic box has plastic or metal internal cable clamps that help secure the cables to the box should it ever slip from the opening. Metal boxes are a bit trickier to use if you're unfamiliar with them, so consider using plastic retrofit boxes for your work.

Neither plastic nor metal retrofit boxes are supported by strong attachments to studs or floor joist; they are supported only by brackets maintaining a taut fit (and maybe the hope that no one will yank on them too much). They are not designed to hold heavy light fixtures or ceiling fans.

To install a box ...

1. *Shut the power off* and remove the existing fixture.
2. Carefully push the wires up and out of the way.
3. Using the back of the retrofit box as a template, draw an outline on the ceiling or wall of the hole you need to cut. Make sure it's smaller than the ears on the box, which will brace against the plaster.
4. Carefully cut the hole with a hole saw or a keyhole saw.
5. Take a screwdriver and, while tapping it with a hammer, punch out one knockout for each cable that will be brought into the box. (Move the screwdriver around to broaden the hole and to clean up any sharp edges.)

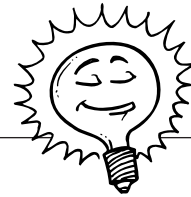

Bright Idea

Always put a large drop cloth or a piece of plastic under your work area when you're cutting through plaster or drywall. The last thing you want is damage to your hardwood floors from falling chunks of plaster. You also don't want to have to vacuum plaster out of your carpet.

6. Bring the old cable or wires into the box.
7. Tighten the mounting bolts on the box. This will tighten the box to the plaster or drywall. Connect the wires to the light fixture and tighten the fixture to the box.

An old fixture installed without an electrical box.



Tighten the clamps to secure the box to the ceiling; in plaster, screw plaster ears to the lath as well.

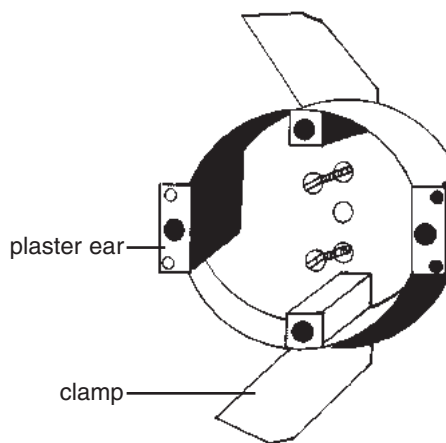

Cutting a hole in plaster or drywall using a keyhole saw is a chore, especially if you have to saw through lath. Most lath in residential construction is wood, but metal lath is sometimes used in expensive homes and requires either tin snips or a hole saw. (The lath will dull the saw's teeth some.) To get a start on your sawing after you've outlined your hole, drill some starter holes in several locations with your electric drill and a twist

bit. For that matter, you can drill a lot of holes all along the outline until you've just about cut out the entire hole. I'm not a purist about this stuff, and I recommend doing whatever you're comfortable with as long as it's safe and works for you.

You have to be careful when cutting through wood lath and be certain your saw blade is sharp. A dull blade and jerky sawing is a great way to pull on the lath, causing it to crack the adjoining plaster. Take your time. Drill more holes if necessary. Don't worry that you're not doing it as fast as an electrician.



Electrical Elaboration

Wood lath is nailed to each stud in a wall. If you saw through it too aggressively with a keyhole saw or a reciprocating saw, it begins to bounce around and crack the adjoining plaster. With the plaster removed for the box, cut down one side of the lath, leaving an inch or so uncut. Cut the other side completely, and then return to your first cut. This way, the lath stays rigid until both cuts are complete. Use a scroll blade for your reciprocating saw. If sawing by hand, use a fine-tooth blade or even a hacksaw blade, which is available with a mini handle that would allow this kind of cutting.

Try a New Style

Styles and fashions change, a fact that's certainly not lost on America's retailers. The dim ceiling fixtures with the square-shaped glass domes from the 1950s and 1960s just don't cut it any more, unless you're into retro-hip lifestyles complete with hula hoops and strange-looking dinette sets. The array of fixture choices today is astounding. Just about any period of fixture can be matched, or a completely updated style can be installed. The only limits are your imagination and your checkbook.

Some fixtures can greatly increase the amount of lighting in a room. A single overhead fixture in a long hallway, for example, might be replaced with track lighting running the length of the hallway, turning it into a great space to display paintings or photographs. As always, make sure your circuit can support the increased current demand should you replace a fixture with one of a higher wattage rating.

There's no need to limit yourself to using incandescent fixtures to replace your existing ones. Fluorescent fixtures, especially compact models, should be considered as well.

* * * Free Preview End * * *

Purchase Required To Gain Total Access

Visit www.propmgmtforms.com To Purchase *Property Management Forms* Package